

- Environmentally Friendly
- Light Powered
- No Batteries
- Reduced Maintenance Costs
- Available on Express Lavatory Systems – SS and MG Series
- Provides Years of Reliable Operation
- Economical
- Requires a Minimum of 400 lux (37 fc)
- GreenSpec® Listed

Specifications

NDITE® technology harnesses the energy of light to power a lavatory system. Photovoltaic cells embedded in the top of the sprayhead of a two- or three-station Express Lavatory System (SS and MG Series), provides this by converting light to energy. These cells provide power to a proprietary power storage and management system. The power is then distributed to the sensors and solenoid to activate the flow of water as needed.

The photovoltaic cells are permanently embedded in the top of the sprayhead with a clear version of Terreon® solid surface material. This provides a high level of vandal resistance and years of trouble free operation. This material can be cleaned with normal cleaning processes and is repairable if damaged.

The NDITE power management module is proprietary unit that stores and provides power to the sensors and solenoid. This efficient module allows the system to work without batteries, eliminating the need to change or dispose of batteries.

Each NDITE-powered sensor uses a conical-shaped transmitting beam, creating a wide detection area. The detection area projects forward 15° to each side and 15° below horizontal. The adaptive infrared sensor automatically adapts to the bowl after power is turned on. The electronically activated solenoid valve has few moving parts providing reliable operation that is unaffected by most chemicals and minerals often present in municipal water supplies. Each lavatory system is powered by one NDITE power management module.

Operation

NDITE technology requires a minimum of light to operate. The initial charge time and number of activations per day will determine what light level is needed. Overall the system needs 400 lux of illumination to operate. Restrooms with 400 lux of lighting will provide a sufficient amount of light to power the system.

After installation the system will require an initial charge time to become operational. Charge time will vary based on the light level. After this the system will function normally and be available for use anytime there is light present in the room. If there is no light present in the room, the system goes into a power-saving mode and will become operational instantly when the lights turn on. In this power-saving mode the system will remain ready to use for up to five days. If the system is left in the dark for five days it will require time to recharge.

Operating Conditions

To ensure years of reliable operation, the following site requirements must be met:

- Illumination on the top of the fixture: 400 LUX (37 foot candles)
- Timeout for automatic lighting: 15-minute delay minimum

The initial charge time and the average number of cycles per hour are illustrated on the graphs shown.

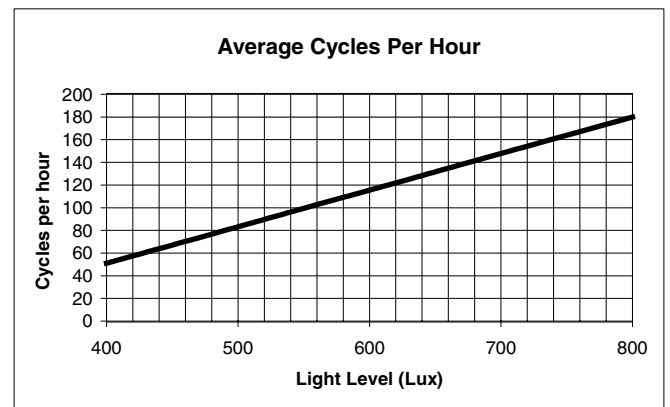
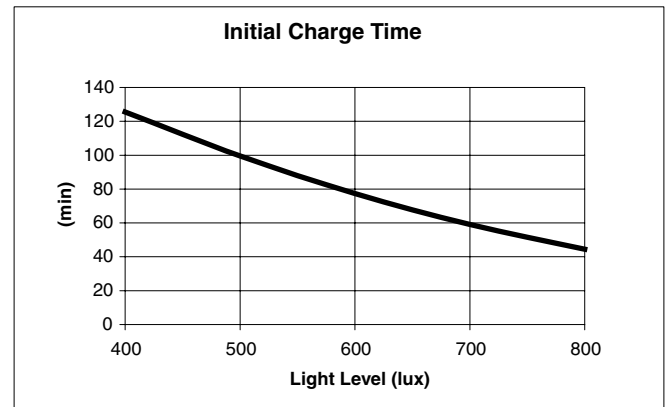
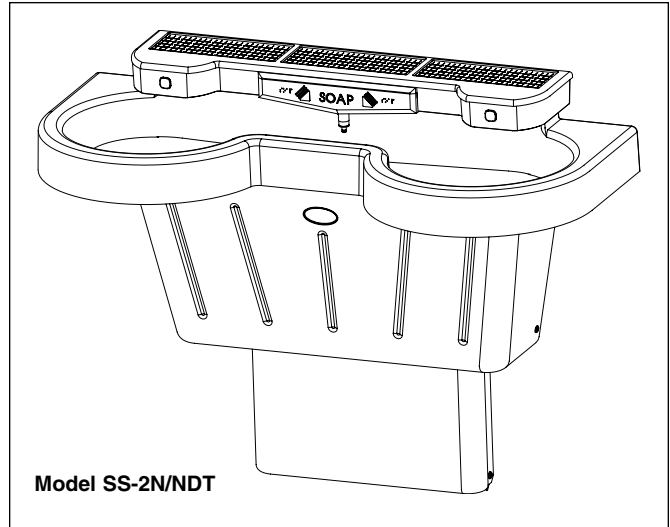

Express® Lavatory System**Model MG-2/NDT**

The modular multiple lavatory system shall provide two handwashing stations, with the centerline of each station located on 30" centers, perpendicular to the mounting wall. Each hand washing station shall comply with ANSI and ADA accessibility standards.

- bowl and sprayhead material for each station shall be constructed of NAHB Certified Terreon, complying with ANSI Z124.3, Z124.6 and ANSI/ICPA SS-1-2001. Bowl and sprayhead finish shall be a decorative stone.
- bowl color: Empire Gray (other colors available)
- lavatory stations shall be secured to a rigid base consisting of a one-piece welded stainless steel subframe which shall support all handwashing stations to ANSI Z124.3 load ratings. Supply and waste connections shall be fully concealed within the frame.
- individual infrared controls powered by NDITE technology. Does not require AC power connections or batteries. NDITE technology provides power through the use of photovoltaic cells to convert light to electricity.
- unit sprayhead assembly to be one-piece design, pre-plumbed and pre-wired and shall provide dry surface ledge above water spray area.
- lavatory system shall include all waste and supply connections to wall, and thermostatic mixing valve with stop, strainer, and check valves.

NOTE: A Lavatory System does not include items such as fasteners, wall anchors, or other components that are job specific.

Express® Lavatory System**Model SS-2/NDT**

The module multiple lavatory system shall provide two handwashing stations, with the centerline of each station located on 30" centers, perpendicular to the mounting wall. Each hand washing station shall comply with ANSI and ADA accessibility standards.

- bowl and sprayhead material for each station shall be constructed of NAHB Certified Terreon, complying with ANSI Z124.3, Z124.6 and ANSI/ICPA SS-1-2001. Bowl and sprayhead finish shall be a decorative stone.
- bowl color: Empire Gray (other colors available)
- lavatory stations shall be secured to a rigid base consisting of a 1 piece welded stainless steel subframe which shall support all handwashing stations to ANSI Z124.3 load ratings. Supply and waste connections shall be fully concealed within the frame.
- Individual infrared controls powered by NDITE technology. Does not require AC power connections or batteries. NDITE technology provides power through the use of photovoltaic cells to convert light to electricity.
- unit sprayhead assembly to be one-piece design, pre-plumbed and pre-wired and shall provide dry surface ledge above water spray area.
- lavatory system shall include all waste and supply connections to wall, and thermostatic mixing valve with stop, strainer, and check valves.

NOTE: A Lavatory System does not include items such as fasteners, wall anchors, or other components that are job specific.