

# Installation

## E19-130

### Drench Shower Vertical Supply

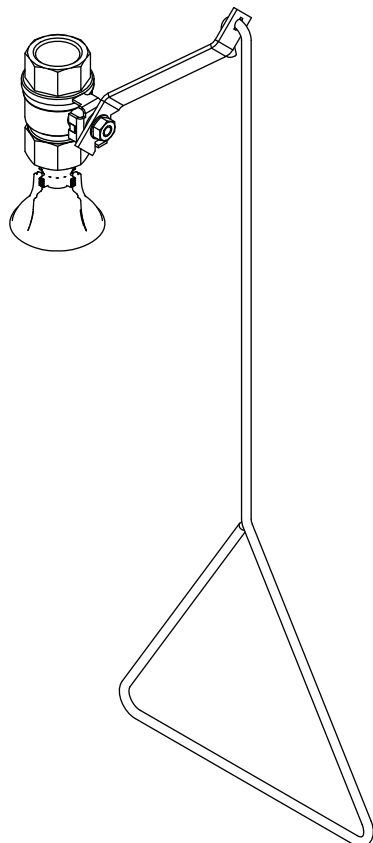

#### Table of Contents

Pre-Installation Information . . . . .	2
Installation Instructions . . . . .	3
E19-130 Components and Parts List. . . . .	4

 **IMPORTANT** 

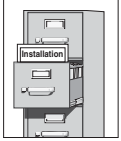

Read this installation manual completely to ensure proper installation, then file it with the owner or maintenance department. Compliance and conformity to drain requirements and other local codes and ordinances is the responsibility of the installer.



Separate parts from packaging and make sure all parts are accounted for before discarding any packaging material. If any parts are missing, do not begin installation until you obtain the missing parts.



Flush the water supply lines before beginning installation and after installation is complete. Test the unit for leaks and adequate water flow. Main water supply to the eyewash should be "ON" at all times. Provisions shall be made to prevent unauthorized shutoff.



The ANSI Z358.1 standard requires an uninterrupted supply of flushing fluid at a minimum 0.21 MPa (30 PSI) flowing pressure. Flushing fluid should be tepid per ANSI Z358.1.



The inspection and testing results of this equipment should be recorded weekly to verify proper operation. This equipment should be inspected annually to ensure compliance with ANSI Z358.1.



Workers who may come in contact with potentially hazardous materials should be trained regarding the placement and proper operation of emergency equipment per ANSI Z358.1.



For questions regarding the operation or installation of this product, visit [www.bradleycorp.com](http://www.bradleycorp.com) or call 1-800-BRADLEY.

Product warranties and parts information may also be found under "Products" on our web site at [www.bradleycorp.com](http://www.bradleycorp.com).

# Installation

## Supplies Required:

- Teflon tape and pipe sealant
- Piping to 1" BSP water supply inlet
- Adequate supply pipe supports
- Minimum 4" (102 mm) drain to accommodate 30 gallons (115 liters) per minute discharge for shower waste
- Sign-mounting hardware

## Step 1: Assemble components

1. Assemble the components as shown on page 4.
  - Apply pipe sealant to all male-threaded pipe joints.
  - Use a strap wrench around pipes when tightening to prevent marring.
  - The bottom edge of the showerhead should be 2134mm (7'-0") from the floor.

## Step 2: Connect water supply



**IMPORTANT: Do not rely on Bradley's Drench Shower to support supply piping.**

1. Connect water supply piping to 1" BSP inlet on unit (piping supplied by installer). Provide adequate supports (supplied by installer) for supply pipe using pipe hangers or other means.
2. Mount the safety sign to the wall using sign-mounting hardware supplied by installer.

**NOTE:** All dimensions assume standard thread engagement. Variations in manufacturing allow for +/- 3mm (1/8") per threaded joint. To find the tolerance of a dimension, add the number of thread joints in between a dimension and multiply it by 3mm (1/8").

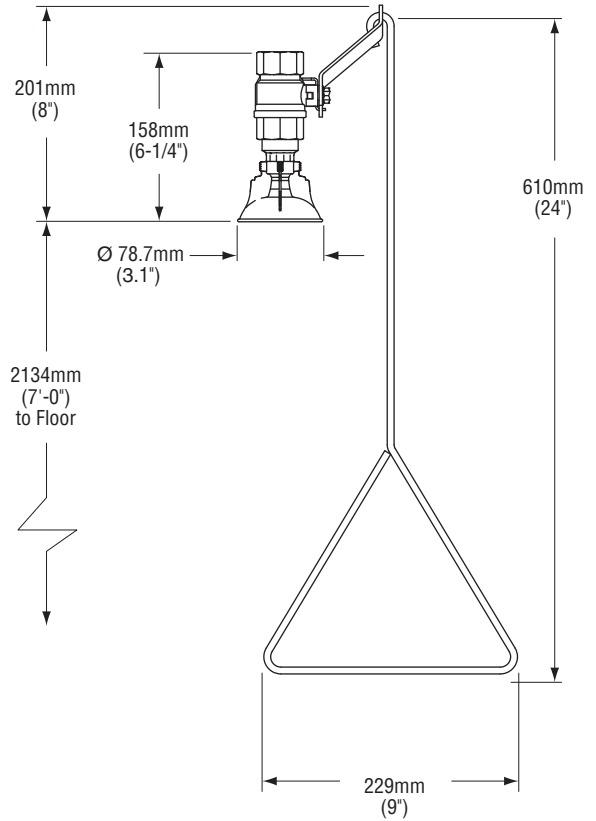

# Assembly of Components and Parts List

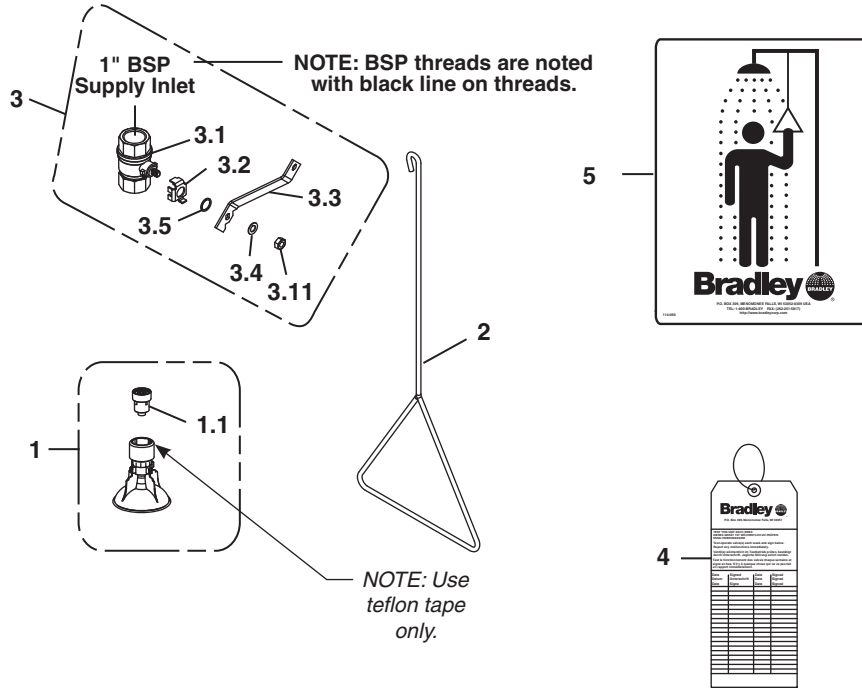

NOTE: Items 31.1–3.5 come preassembled as Item 3.

Item	Part No.	Qty.	Description	Item	Part No.	Qty.	Description
1	S24-188	1	Plastic Showerhead Assembly	3.2	140-720	1	Stop Bracket
1.1	S24-187	1	Flow Control Assembly, 23 GPM	3.3	128-132	1	Handle
2	128-156A	1	Pull Rod - 24" Long	3.4	142-002DC	1	Lockwasher
3	S30-060B	1	Stay-Open Ball Valve Assembly 1" BSP	3.5	124-048	1	Washer
3.1	S27-278B	1	Ball Valve with Jam Nut	4	204-421	1	Emergency Tag
3.11	110-214	1	Jam Nut (only)	5	114-050E	1	Safety Sign