

# Installation

## WC7245

### Chase-Mounted Siphon Jet Stainless Steel Toilet

#### Table of Contents

Rough-Ins .....	2
Installation Instructions .....	3
Cleaning Stainless Steel .....	4



## WARNING

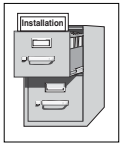

Read this entire installation manual to ensure proper installation. When finished with the installation, file this manual with the owner or maintenance department. Compliance and conformity to local codes and ordinances is the responsibility of the installer.



Separate parts from packaging and make sure all parts are accounted for before discarding any packaging material. If any parts are missing, do not begin installation until you obtain the missing parts.



Before installing components, all connection supply lines must be flushed and free of foreign material such as pipe dope, chips, solder, etc. Bradley will not be responsible for leaking valves due to the presence of foreign material, or distorted stop gaskets where excessive pressure (above 30 lbs. of torque) has been applied to the stop cap.

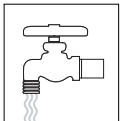

After flushing has been completed, make sure that all water supply lines have been completely turned off before beginning installation. After installation has been completed, turn the water supply lines back on and test the unit for leaks and adequate water flow.



Product warranties may be found under "Product Information" on our web site at [www.bradleycorp.com](http://www.bradleycorp.com).

# Rough-Ins

Dimensions - Top View

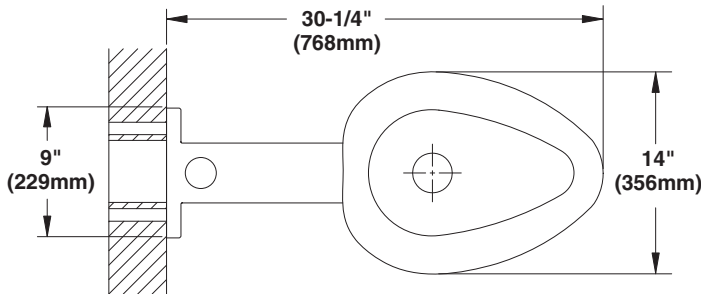

Dimensions - Side View

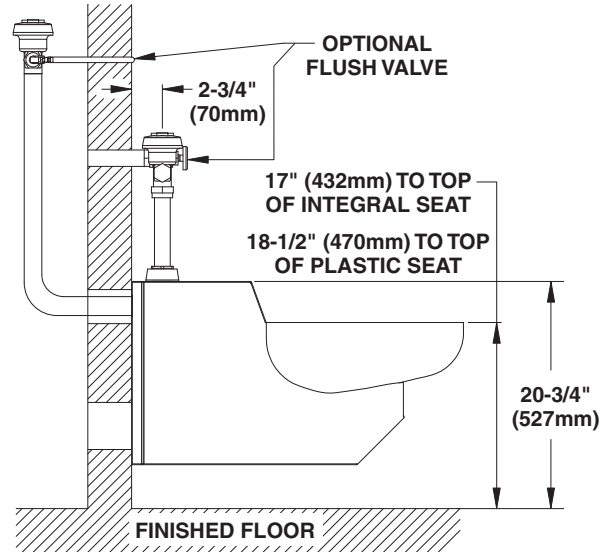

**Rough-Ins**

BACK SUPPLY, 1-1/2" DIA (38mm)  
FOR MECHANICAL PUSH BUTTON  
2" DIA (51mm) FOR HYDRAULIC  
OR TOUCH-TIME PUSH BUTTON

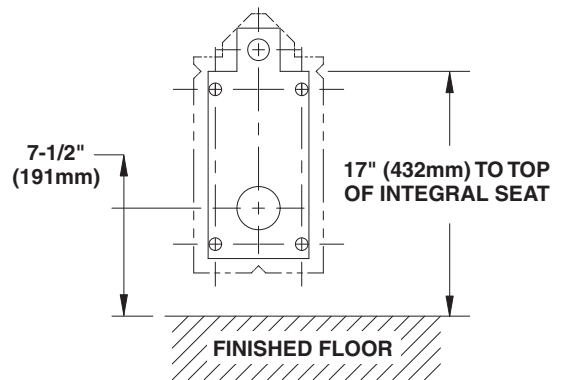
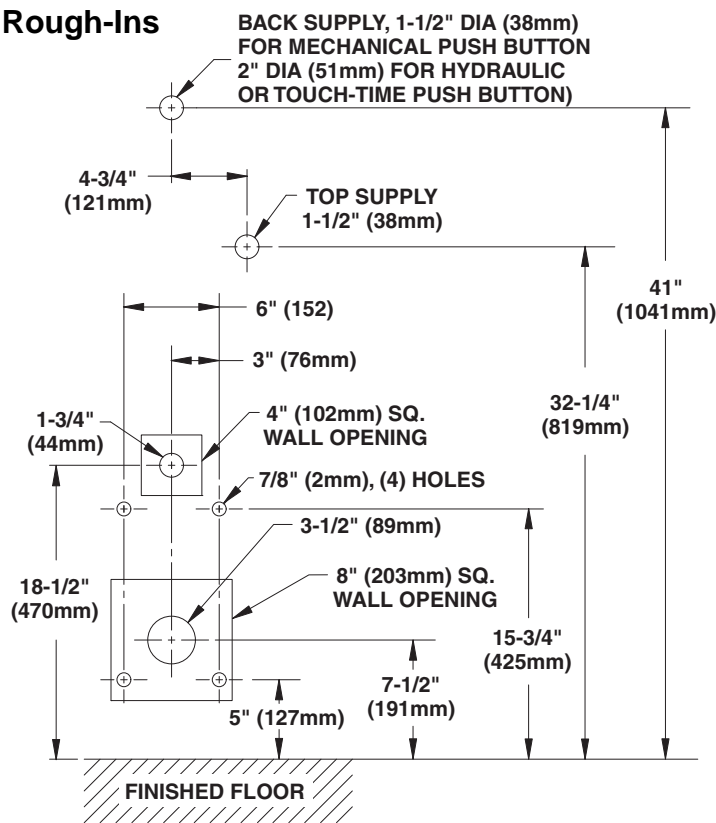

## Supplies Required:

- 1-1/2" NPT supply piping to flush valve
- Waste connection

# Installation

**NOTE:** Back supply is shown, top supply is similar.

**A** Insert the four 1/2"-13 threaded rods (provided) into the back of the unit and screw in approximately 1/2".  
0"-4" (109-039)  
4"-8" (109-040)  
8"-12" (109-048)

**B** **BACK SUPPLY:** Connect the flush valve supply pipe to the 1-1/2" IPS inlet half coupling on the back of the unit.  
**TOP SUPPLY:** Connect the flush valve supply pipe to the 1-1/2" IPS inlet half coupling on the top of the unit.

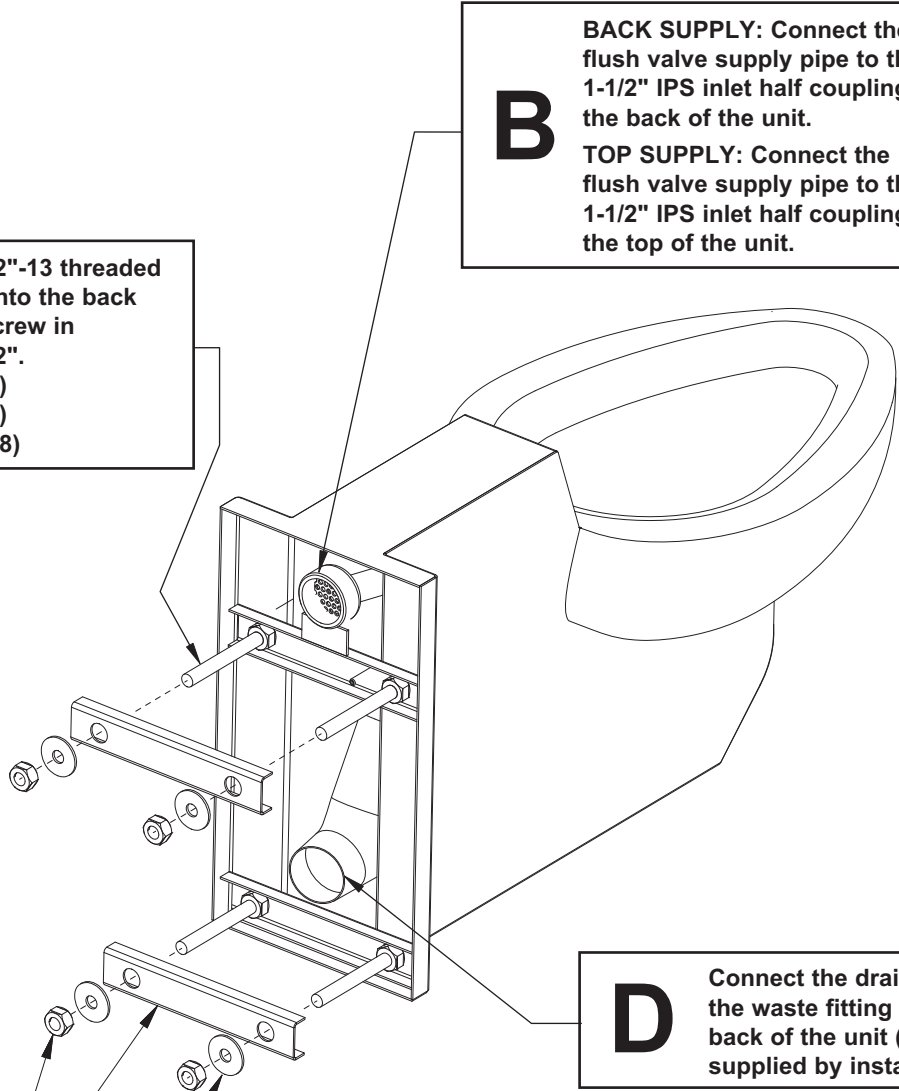

**D** Connect the drain pipe to the waste fitting on the back of the unit (piping supplied by installer).

**C** Slide the studs and pipe through the wall openings and position the unit into place.  
Secure the unit to the wall using the nuts (110-119), washers (142-002AM) and anchor brackets (140-278) provided. Fasteners must be securely tightened to 60 ft. lbs.

# Cleaning Stainless Steel

**Material Description:** Stainless steel is extremely durable, and maintenance is simple and inexpensive. Proper care, particularly under corrosive conditions, is essential. Always start with the simplest solution and work your way toward the more complicated.

**Routine cleaning:** Daily or as often as needed use a solution of warm water and soap, detergent, or ammonia. Apply the cleaning solution per the manufactures instructions and always use a soft cloth or sponge to avoid damaging the finish.

**Stubborn Stains:** To remove stains from stainless steel use a stainless steel cleaner and polish such as Ball® stainless steel cleaner or a soft abrasive. Always follow the manufactures instructions and apply in the same direction as the polish lines.



**IMPORTANT: NEVER USE ORDINARY STEEL WOOL OR STEEL BRUSHES ON STAINLESS STEEL. ALWAYS USE STAINLESS STEEL WOOL OR STAINLESS STEEL BRUSHES.**

## Special Situations for Material

**Fingerprints and Smears:** To remove fingerprints or smears use a high quality stainless steel cleaner and polish in accordance with the manufactures instructions. Many of these products leave a protective coating the helps prevent future smears and fingerprints.

**Grease and Oil :** To remove grease and oil use a quality commercial detergent or caustic cleaner. Apply in accordance to the manufactures instructions and in the direction of the polish lines.

**Precautions:** Avoid prolonged contact with chlorides (bleaches, salts), bromides (sanitizing agents), thiocyanates (pesticides, photography chemicals, and some foods), and iodides on stainless steel equipment, especially if acid conditions exist.



**IMPORTANT: DO NOT PERMIT SALTY SOLUTIONS TO EVAPORATE AND DRY ON STAINLESS STEEL.**

The appearance of rust streaks on stainless steel leads to the belief that the stainless steel is rusting. Look for the actual source of the rust in some iron or steel particles which may be touching, but not actually a part of the stainless steel structure.

*NOTE: Strongly acidic or caustic cleaners may attack the steel causing a reddish film to appear. The use of these cleaners should be avoided.*

**Brand Names:** Use of brand names is intended only to indicate a type of cleaner. This does not constitute an endorsement, nor does the omission of any brand name cleaner imply its inadequacy. Many products named are regional in distribution, and can be found in local supermarkets, department and hardware stores, or through your cleaning service. It is emphasized that all products should be used in strict accordance with package instructions.