

Multi-Fount Washfountains Terrazzo Models

Parts & Service Guide

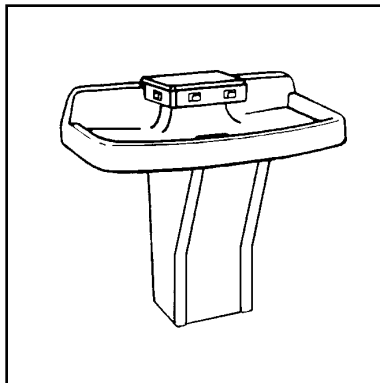
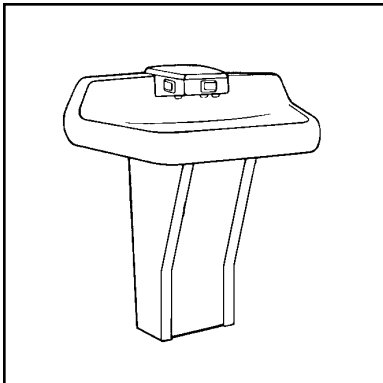

**DISCONTINUED MODELS
PRIOR TO MAY 7, 2007**

Call for Parts Availability



Table of Contents

	Page #
Washfountain Identification	
Identification Chart and Model Numbers	3
Terrazzo Multi-Fount Washfountains	
Infrared (IR) — Sprayhead Infrared and Streamformer Parts	4
Infrared (IR) — Replacing Parts	5
Infrared (IR) — Solenoid Valve Assembly and 24V plug-in transformer	6
Infrared (IR) — Solenoid Valve S07-040 Individual (End), S07-041 Ganged	7
Infrared (IR)— Sensor and Valve Troubleshooting	8
90-75 — Sprayhead 90-75 and Streaformer Parts	9-10
90-75 — Metering Valve Repair Kit S65-084	10
90-75 — Metering Valve Timing Adjustments	11
90-75 — Metering Valve Troubleshooting Instructions	12
90-75 — Cartridge Replacement	13
Supply and Mixing Valve	14
Vernatherm® Thermostatic Mixing Valve S01-116B	15
Soap System	16-18
Drain Spud and Strainer	19
Pedestal Assembly	20
Replacement Pedestal Panels	21
Maintenance Instructions	22

Part numbers are subject to change without formal notice.



Terrazzo Multi-Fount Washfountains

- Highly Vandal Resistant
- Saves Water, Energy, and Space
- Available with 90-75 Metering or Infrared Control

Models Available:	
MF2902	Terrazzo Corner-Fount
MF2903	Terrazzo Tri-Fount
MF2904	Terrazzo Quadra-Fount

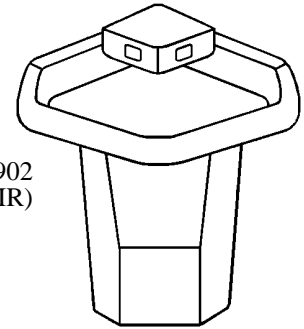

MF2902
Infrared Shown (IR)

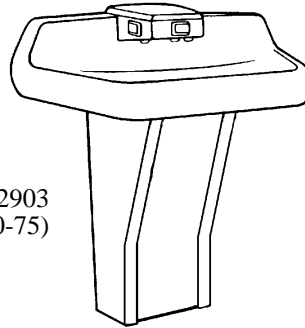

MF2903
Metering Valve Shown (90-75)

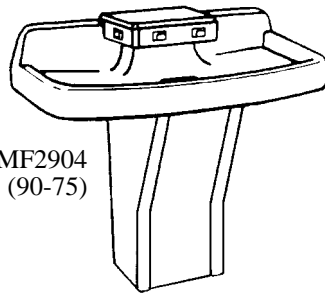

MF2904
Metering Valve Shown (90-75)



Infrared (IR) — Sprayhead Infrared and Streamformer Parts

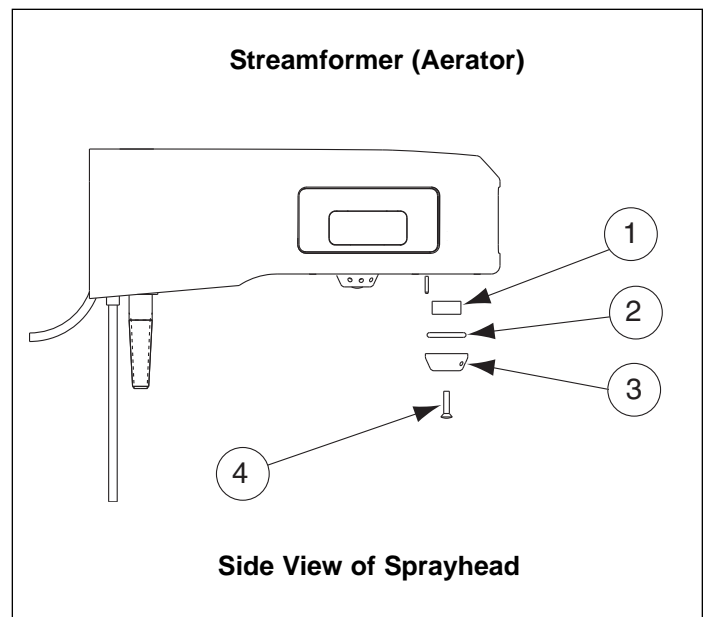
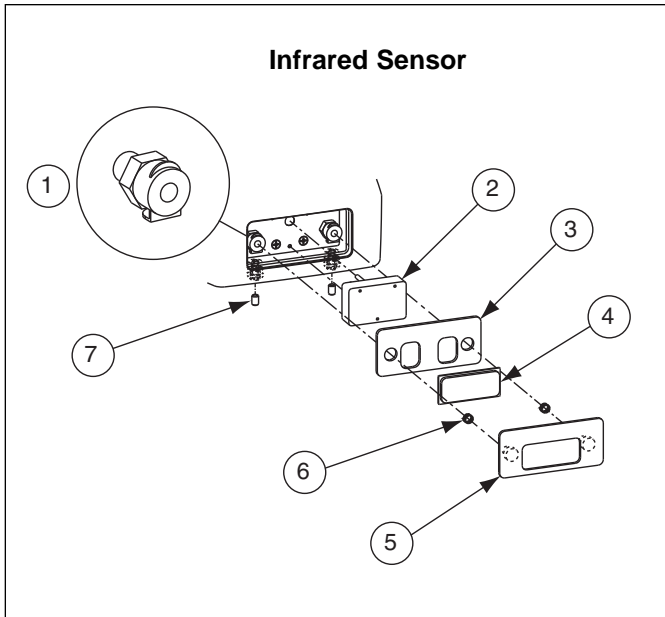

Parts List — Infrared Sensor and Sprayhead Assembly

Item	Part No.	Description	Corner	Tri	Quad
			Qty	Qty	Qty
1	269-382	Coupling Nut - Quick Disconnect	4	6	8
2	S65-107	Multi-Fount Sensor Repair kit (269-1184 w/o connectors)	—	—	—
3	124-070	Gasket, MF Window Terrazzo	2	6	8
4	269-604	Window, IR MF Terrazzo	2	3	4
5	S53-127	Window Plate, IR MF Terrazzo	2	3	4
6	135-049	Spring, Window Plate	2	6	8
7	160-246	Screw 1/4-20 X 3/8, Set SC 18-8 SS	2	6	8
*	269-621	Female Connector (3 required per 269-1184)	6	9	12

* Not Illustrated.

Parts List — Streamformer Assembly

Item	Part No.	Description	Corner	Tri	Quad
			Qty	Qty	Qty
1	269-508	Sprayhead Diffuser MF	4	6	8
2	125-001EG	O-Ring	—	—	—
3	115-125	Streamformer	2	6	8
4	160-246	Screw 8-32 X 3/4, Oval Head	2	6	8



Infrared (IR) — Replacing Parts

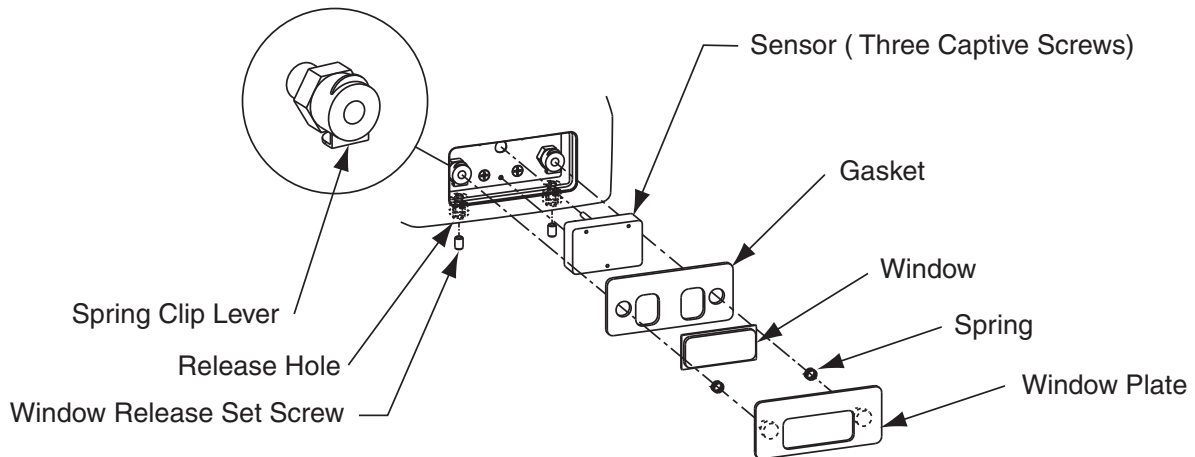

To Change the Sensor or Window:

1. Use an 1/8" allen wrench to remove the window release set screws (Item 7), located under the sprayhead. This allows access to the release holes under the sensor.
2. **The “Spring Clip Lever” gets pushed in to release the sensor assembly from the sprayhead.** Push the allen wrench up into release holes to push on the spring clip lever on the quick disconnect coupling nut (Item 1). This lever will click and lock in the open position to allow removal of the window and sensor.
3. Remove the sensor window plate, window and gasket.
4. Loosen the three screws holding the sensor in place.
5. Cut the insulated terminals off the sensor cable and remove the sensor.

To Reinstall the Sensor or Window:

1. Insert the replacement sensor cable into the cavity and feed thru to the pedestal.
2. From the pedestal below, pull on the sensor cable to pull the remaining cable through.
3. Install and tighten the three sensor screws.
4. Connect the sensor cable terminals.
5. Before reinstalling the window plate, window and gasket, make sure the spring clip lever on the quick release body is pushed in (open). This lever will click and lock in the open position.
6. Position the window gasket over the sensor making sure the sensor eyes align to the gasket holes.
7. Insert the window into the window plate assembly and insert the assembly pins through the gasket. Press firmly on the outer edge of the plate assembly until it clicks (locks) into position.
8. Reinstall the window release set screws on the underside of the sprayhead.



Infrared (IR) — Solenoid Valve Assembly and 24V Plug-in Transformer

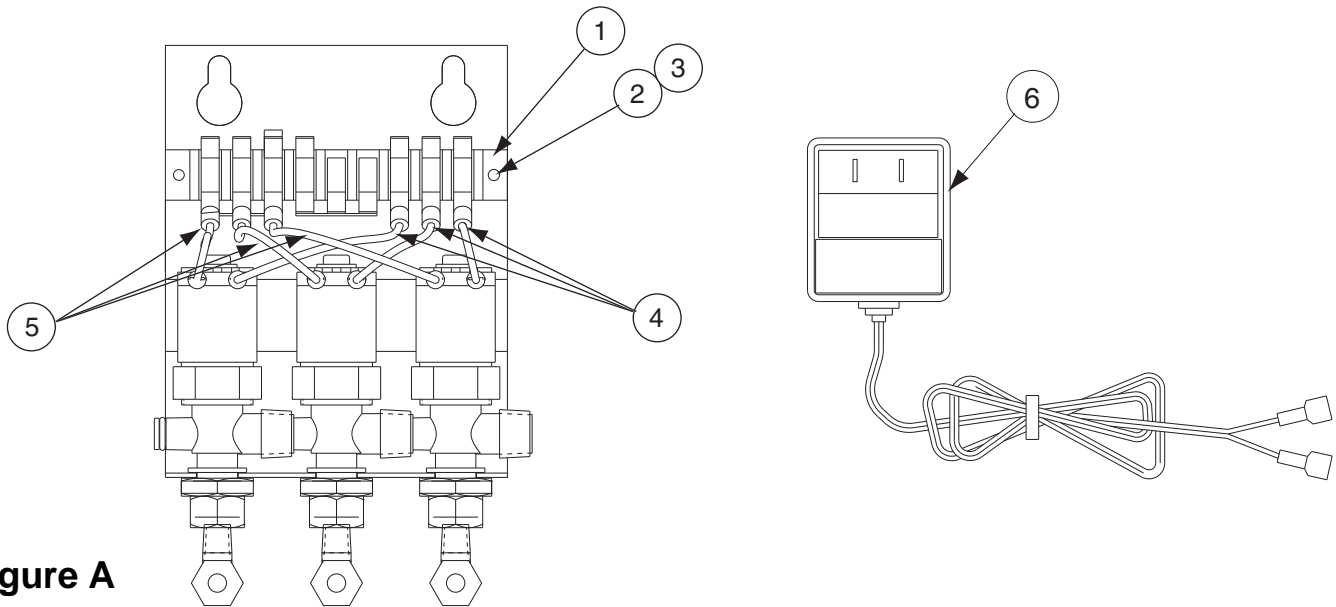

Figure A

Parts List — Solenoid Assembly

Item	Part No.	Description	Corner	Tri	Quad
			Qty	Qty	Qty
*	S08-341	2 Valve Assy. With Bracket	1	—	—
Fig. A	S08-298	3 Valve Assy. With Bracket	—	1	—
*	S08-299	4 Valve Assy. With Bracket	—	—	1
1	269-625	Terminal Block (2 or 3 valve)	1	1	—
1	269-647	Terminal Block (4 valve)	—	—	1
2	160-329	Screw 6-32X3/8 Rd. Hd.	2	2	2
3	161-069	Nut 6-32 Lock	2	2	2
4	S53-129	Wire Assy. Red	2	3	4
5	S53-128	Wire Assy. Black	2	3	4
6	S83-134	Transformer 24VAC (269-901 w/o connectors)	1	1	1

* Not Illustrated.



Infrared (IR) — Solenoid Valve S07-040 Individual (End), S07-041 Ganged

S07-040 Solenoid Valve (Individual)
Used by itself, or is the last one (opposite end of the water inlet) in a group.

S07-041 Solenoid Valve (Ganged)
Used in a group, **except** the last in line. Body is drilled to allow water to pass thru into the next in line. This valve includes O-Ring 125-145 to seal to the next valve.

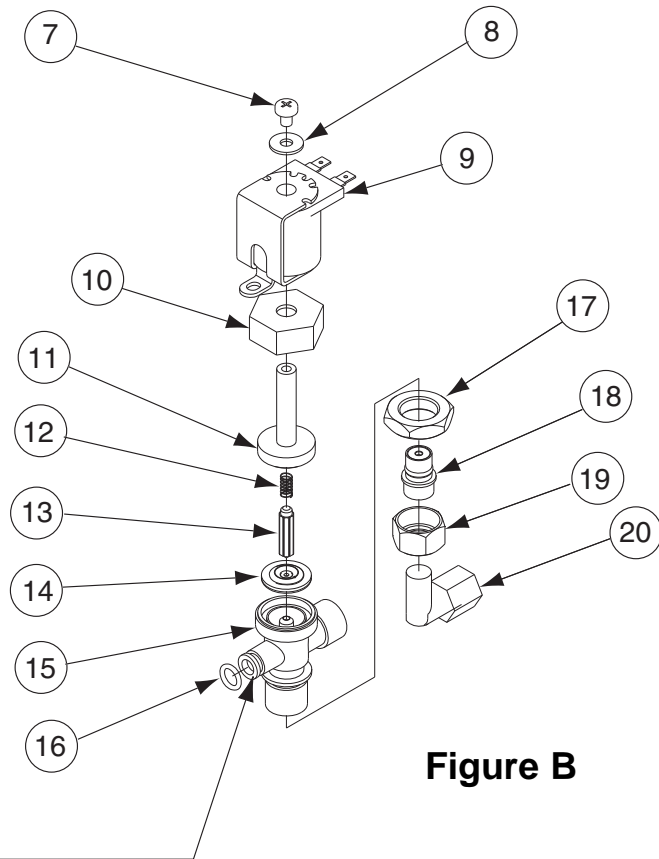

Figure B

Parts List — Solenoid Valve Parts

Item	Part No.	Description	Corner	Tri	Quad
			Qty	Qty	Qty
Fig. B	S07-040	Valve Individual	1	1	1
Fig .B	S07-041	Valve Ganged	1	2	3
7	160-066	Screw 10-24X1/4 Rd. Hd.	2	3	4
8	124-002AZ	Washer Stainless Steel	2	3	4
9	269-579	Coil - Solenoid Valve	2	3	4
10	110-094	Nut - Bonnet	2	3	4
11	121-028	Bonnet	2	3	4
12	269-578	Spring	2	3	4
13	269-577	Armature	2	3	4
14	269-580	Diaphragm	2	3	4
15	118-237	Valve Body Individual	1	1	1
15	118-238	Valve Body Ganged	1	2	3
16	125-145	O-Ring (for ganged valve body only)	1	2	3
17	110-224	Nut 3/8-18 Hex Brass	2	3	4
18	S88-065	Tailpiece Assembly	2	3	4
19	110-195	Tailpiece Nut	2	3	4
20	145-090	Elbow	2	3	4



Infrared (IR) — Sensor and Valve Troubleshooting

If a station is not functioning properly it is most likely either the solenoid valve or the sensor.

Troubleshooting multi station units is fairly easy, as you can swap parts (actually just by changing the wires) and use the process of elimination to figure out which of the 2 parts is causing the problem.

How the system operates:

1. The transformer sends 24 volts to the sensor.
2. The sensor acts only as a switch.
3. When hands go into the active field of the sensor, the sensor activates and sends a power signal on to the solenoid valve.
4. The power signal activates and opens the solenoid valve which allows the water to flow to the sprayhead. The solenoid valve stays open allowing water to flow as long as it is receiving a signal from the sensor (hands remain in the active field).
5. When hands are removed from the active field, the sensor turns off (note some models have a slight delay feature built-in.) and shuts off the power signal to the solenoid valve.

Note: *The solenoid valves will be in-line and will be in the same order as the stations (in other words the center solenoid will operate the center station, the right solenoid will operate the right station).*

Complaint: The center station will not shut off.

1. Disconnect the sensor wires to the center solenoid valve and set them out of the way.
2. Disconnect the sensor wires to the left solenoid valve. Set these wires out of way and make sure they will not make contact with each other or any metal or framework.
3. Connect the wires from the center solenoid valve and connect them to the left solenoid valve.
4. Reconnect the transformer to the wall outlet for power.
5. Use your hands to activate the center station and watch for the water to come out at the left station.

Conclusion:

If the left station works and shuts off, then we know that the **solenoid is the problem** in the center station.

If the **left station does not shut off**, then we know it is the **sensor** in the center station that is causing **the problem**.

Solution:

If the Sensor is the Problem it will have to be replaced. It cannot be repaired or adjusted in any way.

If the Solenoid Valve is the Problem it is most likely due to debris between the valve seat and diaphragm. This happens frequently in new and recent plumbing installations.

Take the solenoid valve apart and clean. Disconnect the wires from the solenoid. Loosen and remove the screw on top of the coil of the solenoid valve. Unscrew the bonnet nut (counterclockwise) and tip forward to remove from the valve body. Remove the diaphragm (269-580). Remove any particles that may have been trapped between the diaphragm and the valve seat. Rinse off the diaphragm and inspect for damage. Make sure both orifices in the diaphragm are open.

Reassemble and retry the solenoid valve. If there is still a problem, replace the solenoid valve.

If ordering replacement solenoid valves, be careful to order correctly, either an “individual” or a “ganged” solenoid valve.



90-75 — Sprayhead 90-75 and Streamformer Parts

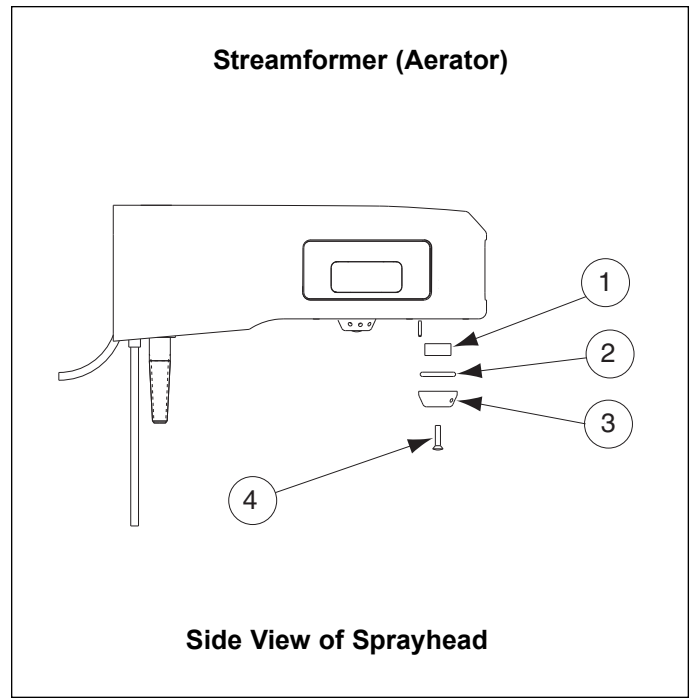
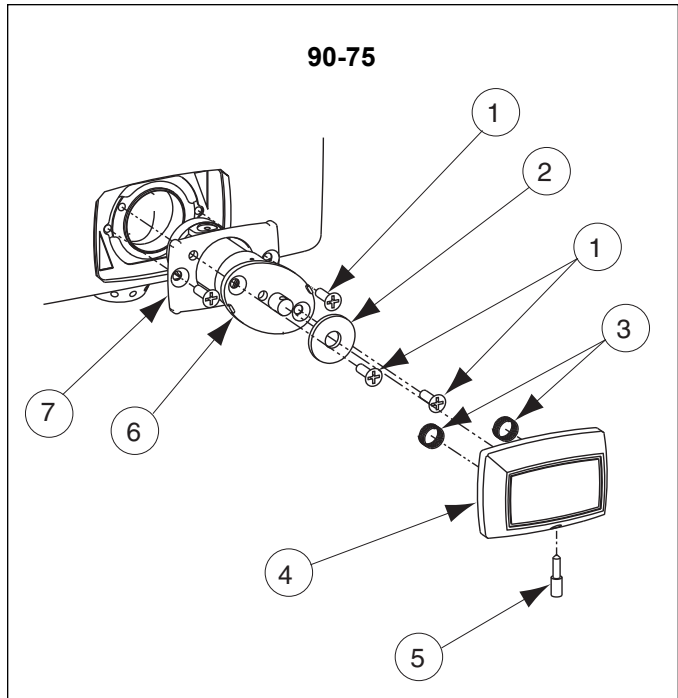

Parts List — 90-75 Valve Assembly

Item	Part No.	Description	Corner	Tri	Quad
			Qty	Qty	Qty
1	P10-132	Screw 8-32X1/2, Phillips Flat Head	4	6	8
2	124-047	Washer, Flat Compressed Foam	2	3	4
3	135-054	Spring, Pushbutton	4	6	8
4	269-186	Pushbutton, Multi-Fount	2	3	4
5	160-300	Screw, Set (Pushbutton)	2	3	4
** 6	S65-084	Repair Kit - Multi-Fount (replacement cartridge)	—	—	—
7	150-116	Celcon Flange 90-75 MF	2	3	4
* 8	S65-067	Pushbutton Service Kit MF (Includes Items 3,4,& 5)	—	—	—

* Not Illustrated.

** See following page for breakdown.

Parts List — Streamformer Assembly

Item	Part No.	Description	Corner	Tri	Quad
			Qty	Qty	Qty
1	269-508	Sprayhead Diffuser MF	4	6	8
2	125-001EG	O-Ring	—	—	—
3	115-125	Streamformer	2	6	8
4	160-246	Screw 8-32 X 3/4, Oval Head	2	6	8



90-75 — Metering Valve Repair Kit S65-084

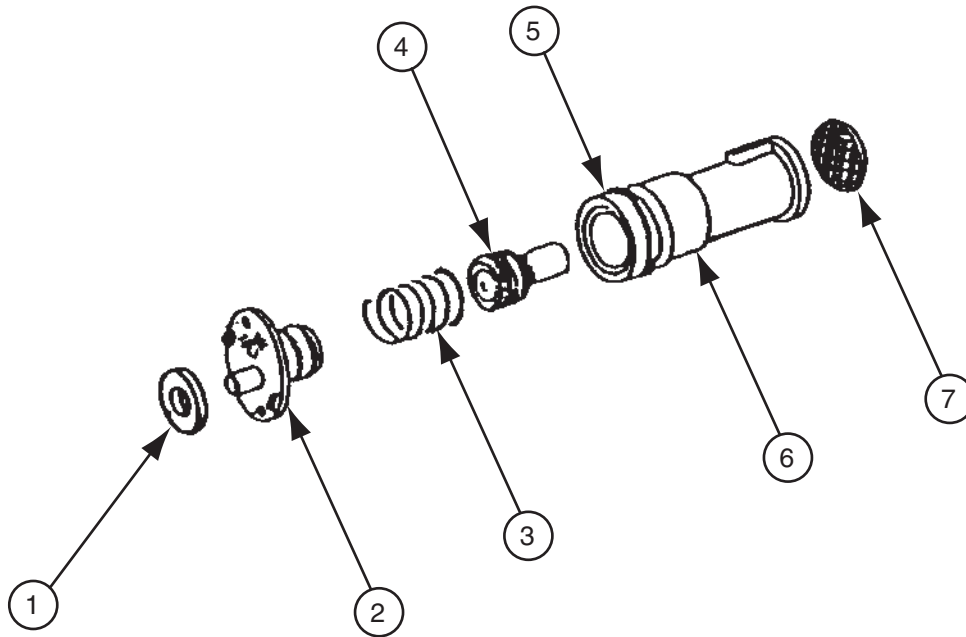

Parts List — Metering Valve S65-084

Item	Part No.	Qty	Description
1	124-047	1	Soap Guard Washer
2	S73-043	1	Upper Valve Body Assembly
3	135-033	1	Spring
4	S64-089	1	Plunger Assembly
5	125-001DD	1	O-Ring
6	S73-031	1	Lower Valve Body Assembly
7	156-010	1	Filter Disk

For areas with poor water quality, use **S65-116 mega orifice cartridge**. Use the mega orifice cartridge if you have frequent “won’t turn off” complaints. Poor water quality will cause mineral build-up in the valve which will restrict the flow and proper operation of the valve.

Note: *The standard cartridge provides a 10-12 second timing cycle. The mega orifice cartridge provides only a 5-7 second timing cycle. The standard cartridge can be changed to the mega orifice by changing the plunger in the standard cartridge to the **S65-091 plunger**.*

Note: *The shorter cycle time of the mega orifice cartridge is not acceptable by ADA standards.*



90-75 — Metering Valve Timing Adjustments

Metering Valve Timing Adjustments

1. The metering valves have been factory tested and adjusted to provide a 10-12 second flow of water from the sprayhead, using 75-85 PSIG pressure and ambient cold water. Varied pressure and/or temperature will affect the length of the timing cycle as follows:
 - Lower inlet pressure will cause a slight increase in the length of the cycle
 - Higher water temperature will cause a slight decrease in the length of the cycle.
2. If further adjustment is needed:
 - Using a 3/32" Allen wrench, loosen the set screw in the bottom of the vandal-resistant pushbutton and lift off the pushbutton (see Figure 10).
 - Insert a 5/64" Allen wrench into the timing adjustment screw located directly in front of the operating stem (see Figure 10). Turn the screw clockwise to shorten the cycle or counterclockwise to lengthen the cycle.
 - Reinstall the pushbutton into the sprayhead and tighten the set screw (see Figure 9).

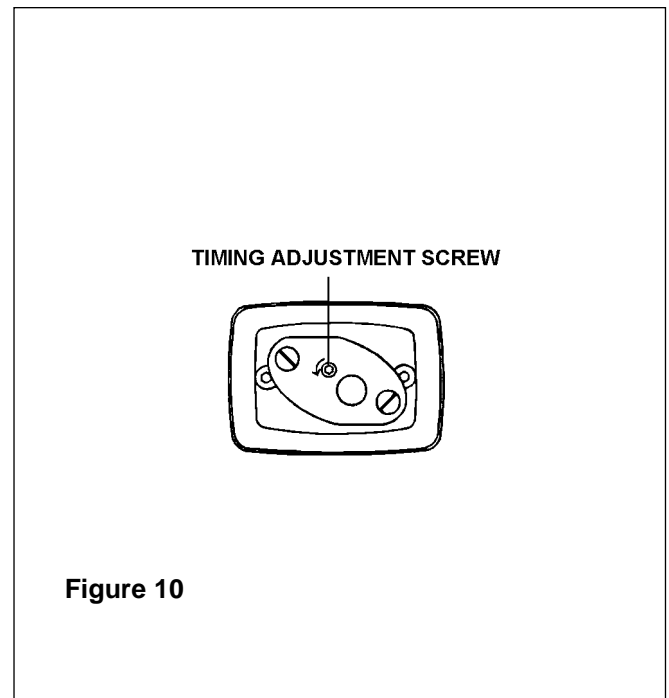
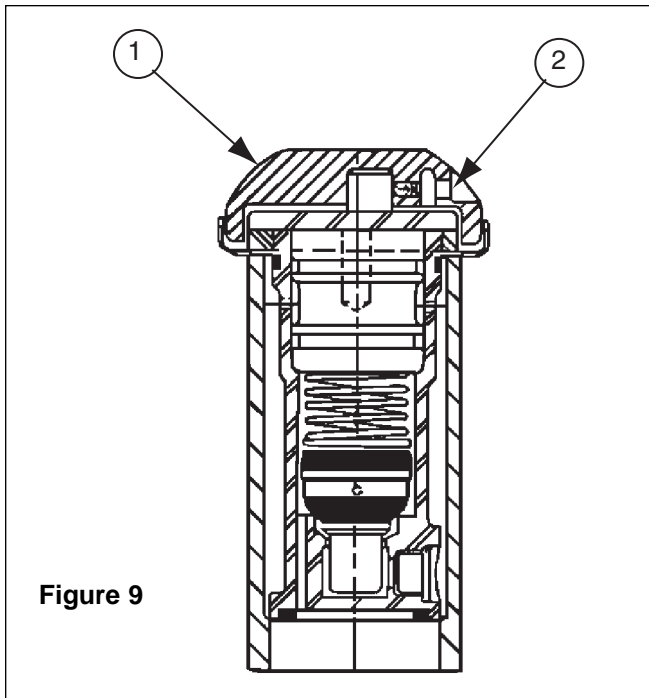

Parts List — Pushbutton Kit S65-067

Item	Part No.	Qty	Description
1	269-186	1	Pushbutton
2	160-300	1	Set Screw
*	135-054	2	Spring (Under pushbutton)

* Not Illustrated.



90-75 — Metering Valve Troubleshooting Instructions

Troubleshooting Instructions

If water just dribbles or does not flow from sprayhead:

Step 1: Turn off water supplies to washfountain

1. Inspect check valves for proper installation.
2. Open the stops and clean the strainers, if necessary.

Step 2: Check metering valve in sprayhead

1. Using a 3/32" Allen wrench, remove the set screw in the bottom of the vandal-resistant pushbutton and remove the pushbutton.
2. Remove the upper valve body.
3. Inspect the plunger seat washer and lower valve body for debris. Clean, if necessary.
4. Inspect the bottom filter disc on the lower valve body for damage or improper placement.

NOTE: When replacing the filter disc on the lower valve body, place three small dabs of grease on the bottom of the lower valve body to hold the filter disc during installation. Do Not block the ports on the bottom of the valve body!

5. Lubricate the plunger with grease.
6. Reinstall the upper valve body and pushbutton. Tighten the set screw.

If water sprayhead delivers all hot or cold water:

Step 1: Turn off water supplies to washfountain

1. Inspect check valves for proper installation.
2. Open the stops and clean the strainers, if necessary.
3. Inspect the mixing valve for proper installation (see page 10).
 - Hot inlet is marked with red paint.

If water flows continuously from sprayhead:

Step 1: Inspect sprayhead for sticking pushbuttons

1. Using a 3/32" Allen wrench, remove the set screw in the bottom of the vandal-resistant pushbutton and remove the pushbutton.
2. Wait 20 seconds. If the valve shuts off, inspect the cavity for debris and clean, if necessary.
3. If flow continues, replace the Metering Valve with Repair Kit #S65-084
4. Reinstall the pushbutton and set screw.



90-75 — Cartridge Replacement

Removing the 90-75 Cartridge

Turn off the water supply before attempting to change the cartridge.

1. Remove the set screw (3/32" allen wrench) located on the bottom of the pushbutton and remove the pushbutton.
2. Remove the two flat head screws located in the face of the cartridge.
3. Rotate the cartridge 90° and wiggle slightly as you pull the cartridge out of the sprayhead.

Note: *Watch for the round filter disk located on the back side of the cartridge to be sure it comes out with the cartridge. If this filter disk remains stuck in the cavity, use a screwdriver to remove it.*

Replacing the 90-75 Cartridge

1. Place three small dabs of grease (provided in the kit) on the back side of the cartridge to hold the filter disk in place while installing. Be sure not to block ports on the bottom of the cartridge.
2. Insert the cartridge into the cavity with screw holes rotated 90°. This will make it easier to locate the cartridge seat (filter disk).
3. Rotate the cartridge to align the screw holes and reinstall the flat head screws.
4. Reinstall the pushbutton and set screw.



Supply and Mixing Valve

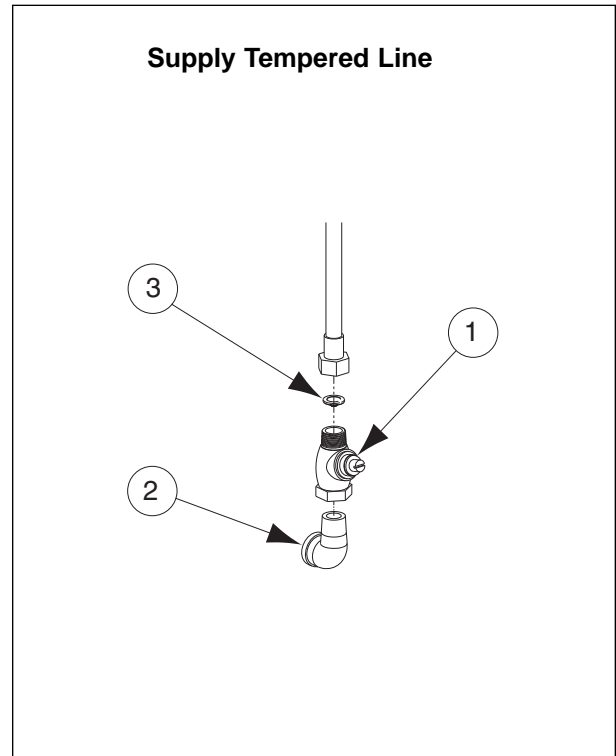
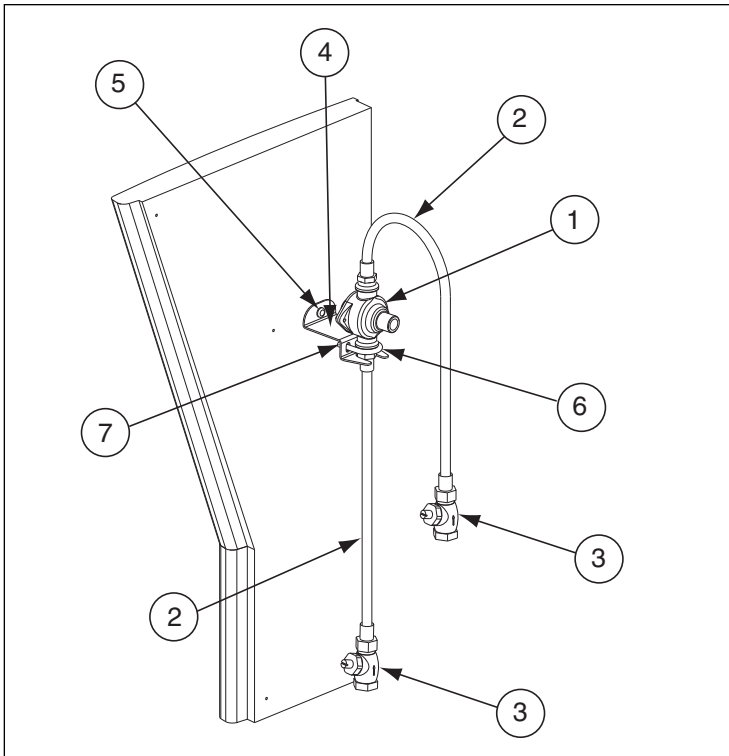

Parts List — Supply Thermostatic Mixing Valve

Item	Part No.	Description	Corner	Tri	Quad
			Qty	Qty	Qty
1	S01-116B	Thermostatic Mixing Valve - Vernatherm	1	1	1
2	269-653	Flex Hose 1/2" NPT x 24" (Supply to TMV)	2	2	2
3	S27-102	Check Stop (use with TMV)	2	2	2
4	140-889	Bracket TMV	1	1	1
5	160-169	Screw	1	1	1
6	269-1248	U-Bolt	1	1	1
7	161-026	Nut (For U-Bolt)	2	2	2
* 8	269-1365	Braided Flexible Hose (Attaches to outlet of Thermostatic Mixing Valve)	1	1	1
* 9	269-1188	Filter Washer	2	2	2

* Not Illustrated.

Parts List — Supply Tempered Line

Item	Part No.	Description	Corner	Tri	Quad
			Qty	Qty	Qty
1	S27-102	Check Stop	1	1	1
2	169-639	Fitting 90° Street Elbow	1	1	1
3	269-1188	Filter Washer	1	1	1



Vernatherm® Thermostatic Mixing Valve S01-116B

*Repair kit S45-049 is pre-packaged and includes O-Ring, Flip Ring, Power Element and Spring.

Maintenance Instructions

1. Disassemble the Vernatherm™ Valve as shown, being careful not to damage the power element. Replace the element, if necessary.
2. If necessary, remove the old flip ring and replace with a new ring.

NOTE: An old or worn flip ring may cause temperature fluctuation and/or water chatter.

3. Reassemble the power element and valve body. Apply grease to the main valve slide and gently ease into position, rotating so that grease is applied to the flip ring. Do not force the slide as this may push the flip ring from its position. To test, rotate the slide; a slight drag should be felt when correctly installed.
4. Reassemble the valve.

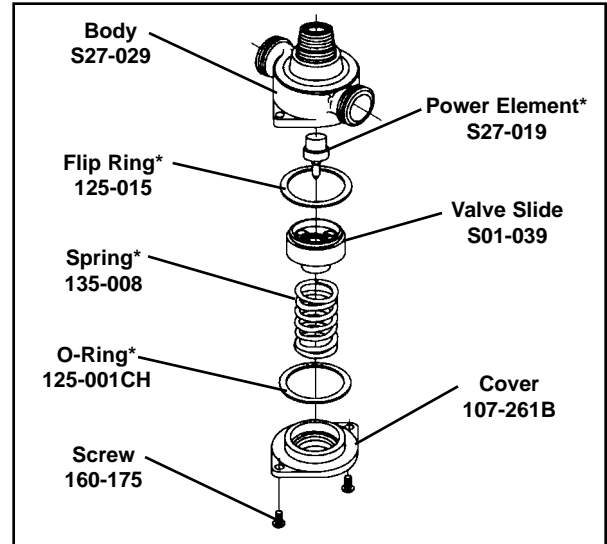

Service Suggestions

When servicing the Vernatherm™ valve, make sure it is installed in the correct position. The most common error that occurs is when the valve is installed in the reversed position, that is, the hot line is connected to the cold line and the cold is connected to the hot.

NOTE: A red ring is painted on the hot side of the valve.

The table below lists conditions that occur when the valve is installed correctly, and when it is in the reversed position.

IF			THEN
Valve Position is	Hot Supply	Cold Supply	Valve Delivers
Correct	Hot	Cold	Mixed 107°
Correct	Hot	No Water	Valve shuts off or drips
Correct	No Water	Cold	Valve shuts off or drips
Correct	Hot	Hot	Hot
Correct	Cold	Cold	Cold
Reversed	Hot	Cold	Cold/below 107° Hot/above 107°
Reversed	Hot	No Water	Hot
Reversed	No Water	Cold	Cold
Reversed	Hot	Hot	Hot
Reversed	Cold	Cold	Cold

Soap System

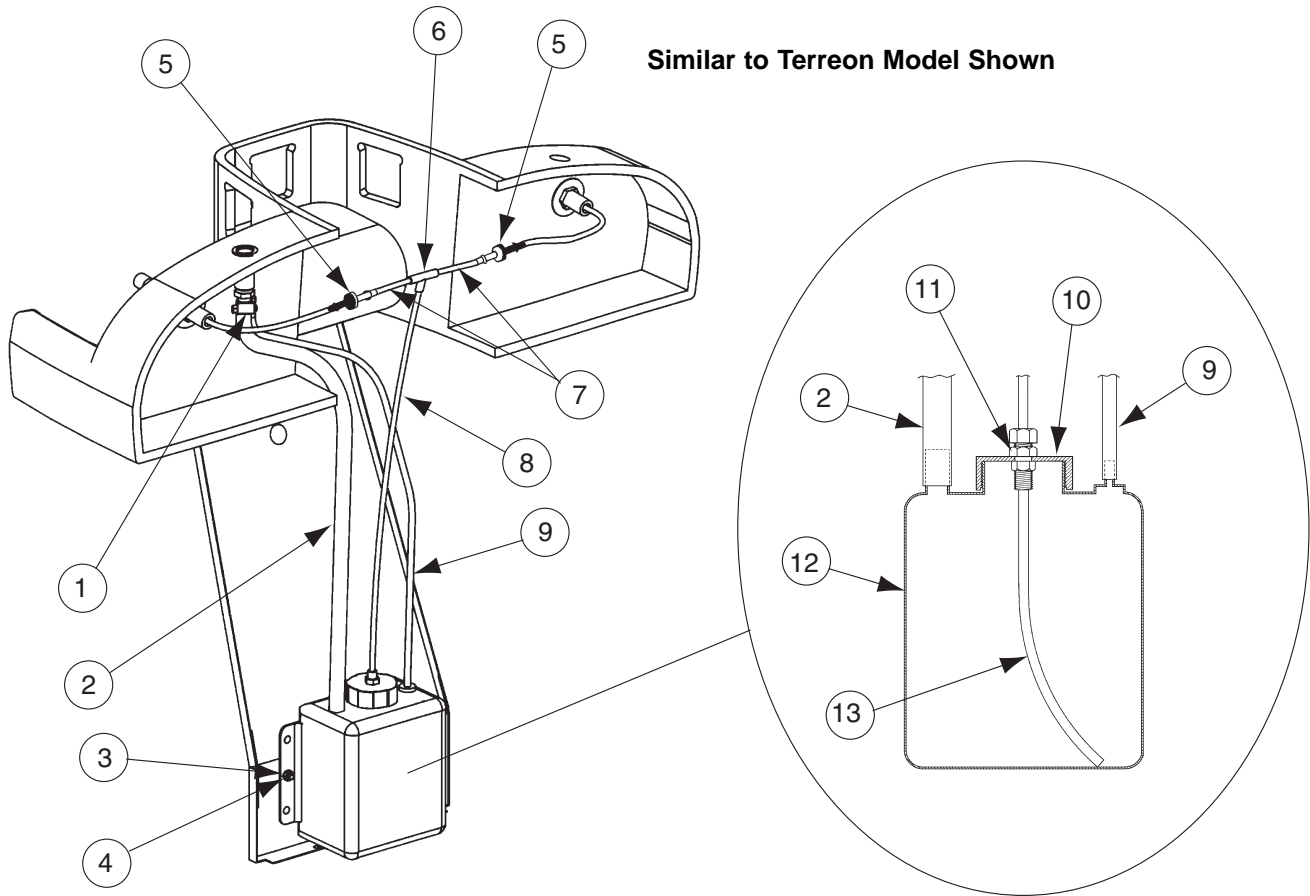

Parts List — S09-075 Complete Soap System Assembly

Item	Part No.	Qty	Description
1	146-040	1	Hose Clamp
2	169-989	1	Filler Hose
3	161-026	1	Nut
4	142-002AV	1	Washer
5	269-028	2	Check Valve
6	169-966	1	Tee
7	169-928	2	Tube 1/8" ID (Specify length in feet)
8	169-928	1	Tube 1/8" ID (Specify length in feet)
*	S57-058	1	Draw Tube Assy. Includes: 5 thru 8
9	R68-600021	1	Vent Tube 3/16" ID x 48"
10	136-031	1	Cap for soap tank
11	269-021	1	Bulkhead Fitting for soap tank cap
12	240-001	1	Soap Tank
13	169-928	1	Tube 1/8" ID (Specify length in feet)

Table continued on next page.



Soap System

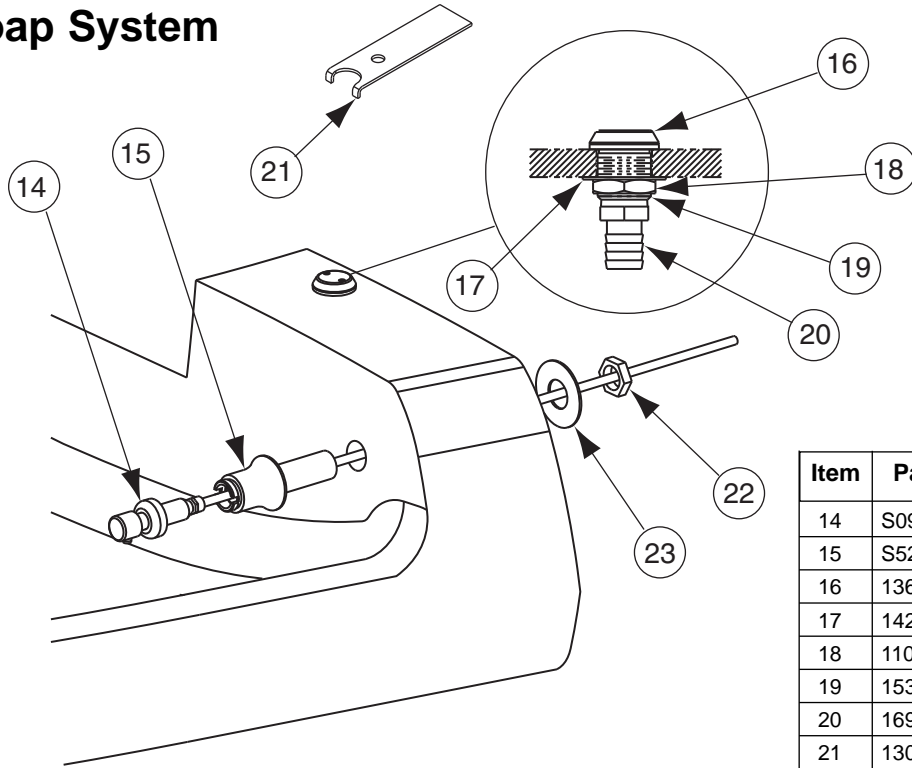

Item	Part No.	Qty	Description
14	S09-078A	2	Soap Valve
15	S52-109	2	Soap Valve Body Assy.
16	136-011	1	Filler Cap
17	142-002CJ	1	Washer
18	110-093	1	Nut
19	153-174	1	Filler Body
20	169-916	1	Connector Male
21	130-142	1	Wrench for filler cap
22	110-115	2	Hex Nut
23	142-002CB	2	Washer

Parts List — Soap System Assy. S09-075

Parts List — Soap Valve S09-078A

Item	Part No.	Qty	Description
1	S64-030	1	Plunger Assy.
2	110-227A	1	Collar
3	160-239	1	Set Screw
4	125-056	2	U-Cup
5	125-001DH	2	O-Ring
6	S68-004	1	Seat Assy.
7	135-035	1	Spring
8	144-043A	1	Cylinder
9	169-964	1	Nut
10	169-928	1	Tube 1/8" ID (Specify length in feet)

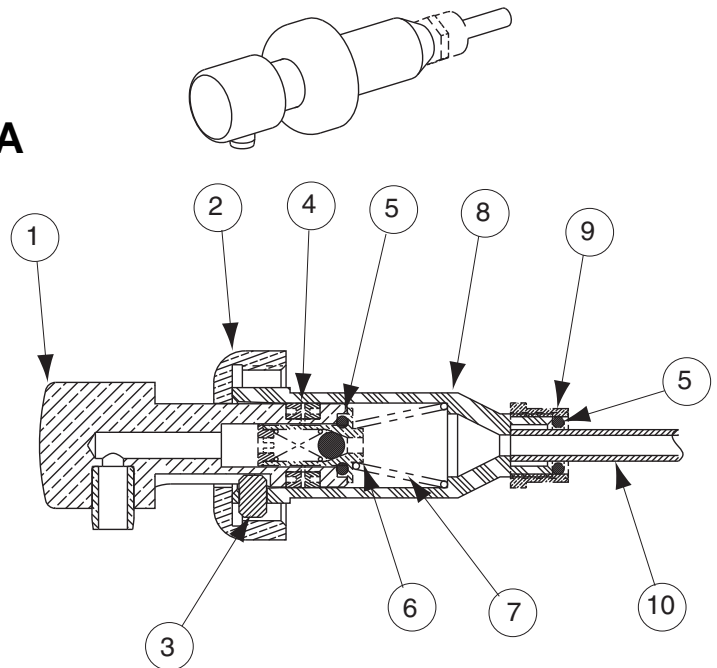



Soap SystemContinued

SOAP RECOMMENDATIONS

Quality soap dispensers require good quality soap and periodic maintenance to properly operate. Bradley soap dispensers will provide dependable, consistent operation over the long term when soap with reasonable viscosity and pH levels are used and when a minimal amount of periodic maintenance is performed on the valves.

Soap thickness is determined by a measurement called viscosity. Soap viscosity should be between 100 cps (centerpoise) and 2500 cps for all Bradley soap dispensers. Thinner soaps are perceived by the users as being "watered down" so users tend to take more than they need, resulting in waste. Thick soaps flow slower and inhibit the "flushing" action of the valves, which allows the soap to congeal in the valve and cause clogs.

The pH (acid) level of the soap should be in the range of 6.5 to 8.5. More acidic soaps (pH levels lower than 6.5) will corrode metal parts (even stainless steel!!) and degrade rubber and plastic components. They will also cause skin irritation. Most inexpensive soaps (typically the pink lotion type) fall into this acidic category and will eventually cause valve failure and metal corrosion. Base soaps (pH levels higher than 8.5) will cause swelling or degradation of rubber and plastic parts and skin irritation.

Generally, any quality soap meeting the viscosity and pH guidelines above will work well with Bradley soap dispensers. PCMX or Isopropanol based antibacterial soaps (within viscosity and pH limits) will also work with Bradley dispensers. Soaps satisfying these basic guidelines will provide consistent flow and reduce clogs.

Most soap dispenser problems are caused by soap that is too thick or corrosive, or by a lack of maintenance. Many soaps come in concentrate form which must be diluted with water. Often, the soap is improperly diluted or used straight out of the bottle, which causes clogging and valve failure. If proper soap is being used, valves that have never been cleaned are usually the source of dispensing problems. Bradley has entered into an agreement with Champion Brand Products to provide additional customer service for purchasers of our dispensers regarding soap issues. They are very helpful and can get to the bottom of almost any soap dispenser related problem. They also sell an excellent "Bradley approved" soap. Please see **Soap Instruction Sheet 215-1286** for details about soap valve cleaning or how to contact Champion. With proper maintenance and soap, Bradley dispensers will provide long term, trouble free operation.

SOAP DISPENSER MAINTENANCE INSTRUCTIONS

Multi-Fount Washfountains

Bradley soap dispensers will provide dependable, consistent operation over the long term when the proper soap is used and when a minimal amount of periodic maintenance is performed on the valves. Valves must be maintained (cleaned) to function properly.

To ensure proper operation of your soap dispenser, follow these instructions:

- Once per month, remove the cap from the soap tank and insert the draw tube (below the cap) into hot water and soak it for 30 minutes.
- Push valve at least 20 times while it is soaking.
- Flush soap reservoir with hot water while valve is soaking.

In cases of extreme clogging, the valve should be disassembled and the parts should be soaked in hot water or cleaning solution to restore proper functioning. Soap dispensers that will not be used for extended periods of time (schools during summer break, etc.) should be drained, cleaned and left empty until put back into service. Soap left on the outside of dispensers can cause discoloration and corrosion of the reservoir (even on stainless steel units). All soap should be wiped or scrubbed off daily, then the outside of the dispenser should be rinsed with clear water and dried with a soft cloth.



Drain Spud and Strainer

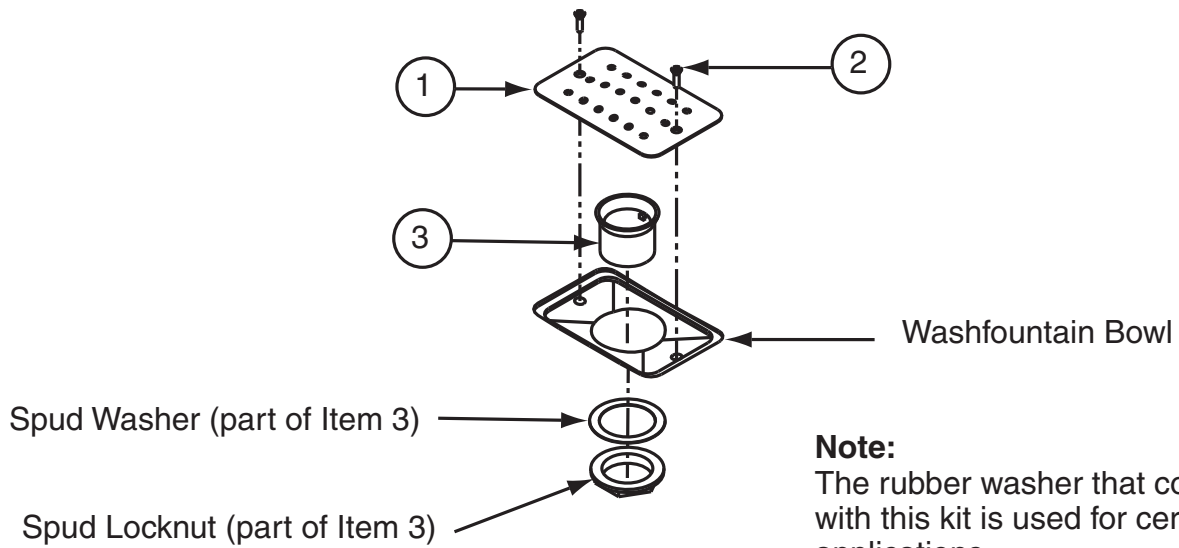

Note:

The rubber washer that comes with this kit is used for certain applications.

Discard this washer for this application as it is not used on Washfountains.

Parts List

Item	Part No.	Qty	Description
1	173-023	1	Dome Strainer
2	160-248	2	Screw 10-24 x 1/2" (for strainer)
3	112-029	1	Drain Spud (includes washer & nut)



Pedestal Assembly

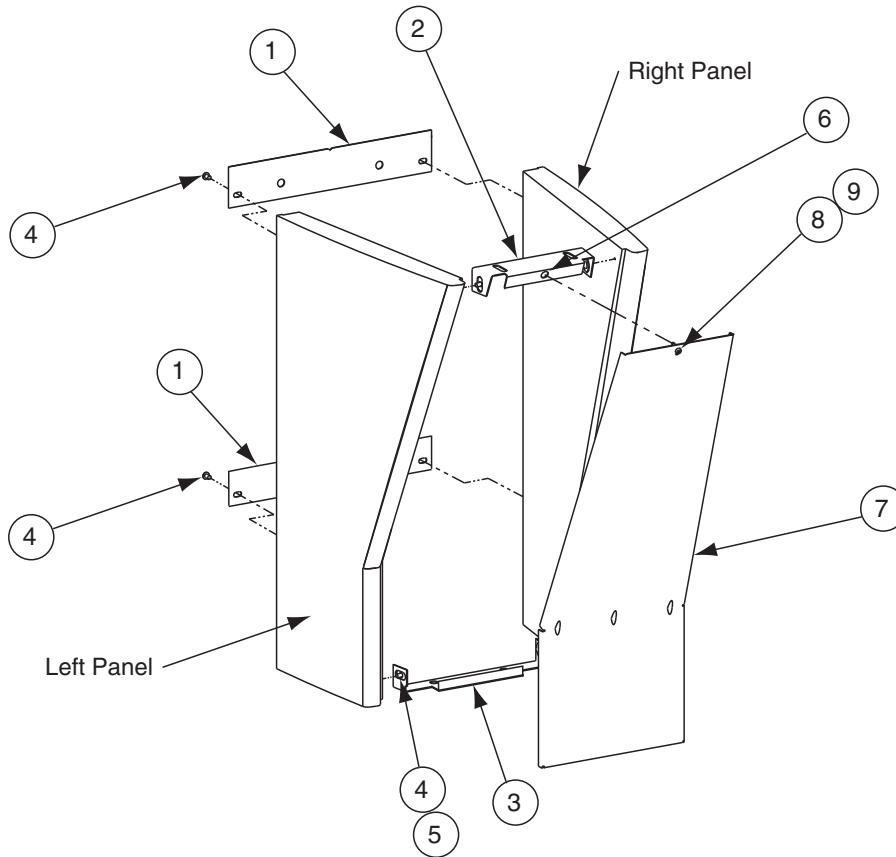

Parts List — Pedestal

Item	Part No.	Description	Corner	Tri	Quad
			Qty	Qty	Qty
1	186-1589	Mounting Panel	2	—	—
1	186-1589	Mounting Panel	—	2	—
1	186-1590	Mounting Panel	—	—	2
*** 2	S04-056	Upper Bracket Assembly	1	1	—
*** 2	S04-057	Upper Bracket Assembly	—	—	1
3	140-1011	Lower Bracket	1	1	—
3	140-1012	Lower Bracket	—	—	1
* 4	160-389	Screw ¼-20	8	8	8
* 5	142-002BJ	Washer	4	4	4
6	146-055	Clip	1	1	1
7	S04-100	Access Panel — Standard Height	1	1	—
7	S04-095	Access Panel — Juvenile Height	1	1	—
7	S04-101	Access Panel — Standard Height	—	—	1
7	S04-096	Access Panel — Juvenile Height	—	—	1
** 8	132-031	Washer	1	1	1
** 9	147-019	Screw	1	1	1

* Not Illustrated

** Access panel (Item 7) part numbers include the screw and washer.

*** Upper Bracket Assembly Includes Item 6.



Replacement Pedestal Panels

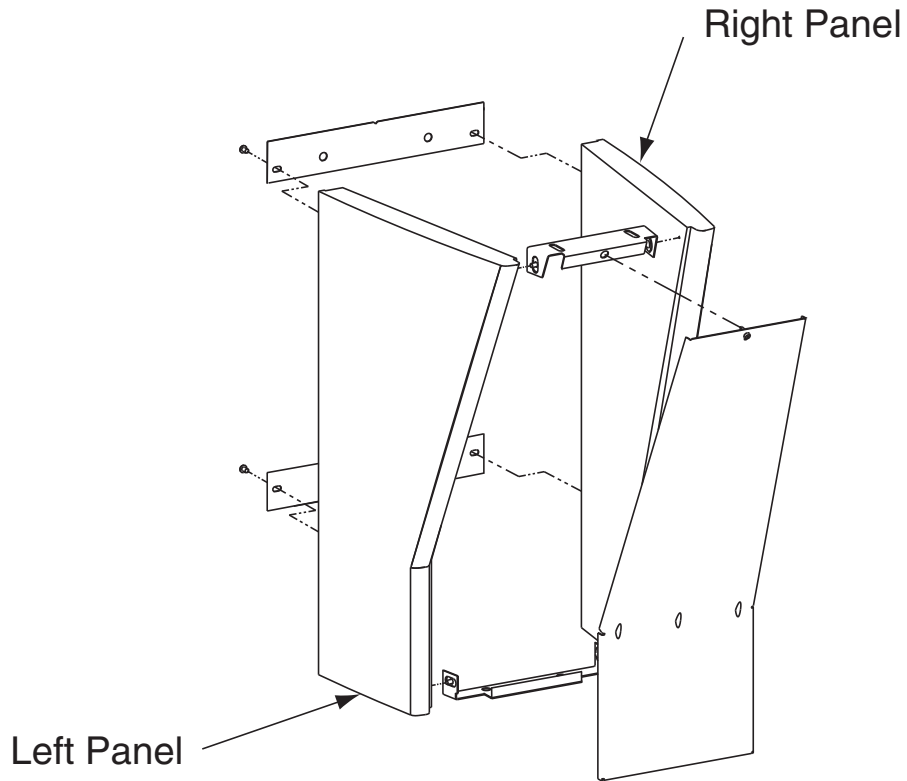

Replacement Panel Part Numbers — MF2902, MF2903, MF2904

Color	Juvenile Height Right Panel	Juvenile Height Left Panel	Standard Height Right Panel	Standard Height Left Panel
Granito	S15-109P	S15-106P	S15-078P	S15-081P
White Marmorite	S15-110P	S15-107P	S15-079P	S15-082P
Whisper Gray	Please call Bradley for ordering information			
Dusty Rose	Please call Bradley for ordering information			



Maintenance Instructions

NOTE: The Bradley Terrazzo Multi-Fount bowl is made of a pre-cast material that has been covered with a polyurethane finish. With regular cleaning and periodic maintenance, the bowl will provide years of dependable service.

Step 1: Clean bowl



IMPORTANT: Do not use scouring pads, cleansers, bowl cleaners or acidic products.

1. Wipe down the bowl daily to remove soap film and residue.
2. Once a week, give the bowl a thorough cleaning with any non-abrasive household cleaner, such as Lysol® Tub & Tile Cleaner.

Step 2: Treat bowl

1. The bowl should be treated periodically with regular marine wax or a commercial product such as Marble Magic™ to maintain the bowl's shine.
4. Should the bowl's clear surface finish become scratched or worn away, the bowl should be recoated to prevent damage to washfountain.
 - Scratches and worn spots can be touched up with marine polyurethane, available from boat and marine supply dealers.