

# Express® Lavatory System — SS-Series Texas Accessibility Standards Compliant

- Model SS-3/IR/WHTAS (Wall-Hung w/ Infrared Control)
- Model SS-3/AST/WHTAS (Wall-Hung w/ Air Valve Metering)
- Model SS-3/BIR/WHTAS (Wall-Hung w/ Battery Operated Infrared Control)
- Model SS-3/TT/WHTAS (Wall-Hung w/ Touch Time™ Metering)

- Serves One to Three Users at a Time
- Continuous Bowl is constructed of Vandal Resistant Terreon® Solid Surface Material
- Standard Lavatory Spacing on 30" Centers
- Available in 18 colors
- Reliable Infrared Activation, Pushbutton Air Valve, Battery Operated Infrared or Touch Time™ Metering Control

## Specifications

Model SS-3WHTAS accommodates one to three users. These units handle washroom traffic quickly and economically while providing each user with personal space. The lavatories for the Express® system are positioned on 30" centers. The preassembled sprayhead module is equipped with independent streamformers, each served by separate infrared sensing module and solenoid valve (Model SS-3/IR/WHTAS), pushbutton air metering valve (Model SS-3/AST/WHTAS), a single valve control box (Model SS-3/BIR/WHTAS) or pushbutton Touch Time™ electronic metering valve (Model SS-3/TT/WHTAS). Standard flow rate of .5 GPM meets industry standards for water conservation while providing enough water to rinse hands quickly and efficiently. Operating range is 20-80 PSI.

## Construction

### Bowl/Sprayhead Cover

Constructed of Terreon®, a densified solid surface material composed of polyester resin. Terreon® is resistant to chemicals, stains, burns, and impact. Surface damage can be easily repaired with everyday cleansers or fine grit abrasives. Terreon® is NAHB certified to meet ANSI Z124.3, Z124.6 and ANSI/ICPA SS-1-2001.



### Pedestal/Scuff Panels

Panels are composed of vacuum-formed acrylic laminate. Highly resistant to impact, abrasion, acid and corrosion. The panels will not chip, peel or flake.

### Support Frame

Bowl assembly and panel are secured to a heavy gauge stainless steel support frame mounted to wall.

### Vandal Resistance

The molded sprayhead is an integral part of the bowl module. Its concealed vandal resistant streamformers discourage abuse. The infrared sensor will automatically shut off water flow after 30-45 seconds if a vandal attempts to trigger constant operation by covering the sensor, or by placing a stationary object in the sensor's detection area. Pushbuttons are secured to the unit from inside the sprayhead. Air valves, water supplies, control boxes and waste are concealed within the pedestal/support frame assembly.

Document No. 1070

This information is subject to change without formal notice.  
0902BLCE (4 Pages Total)

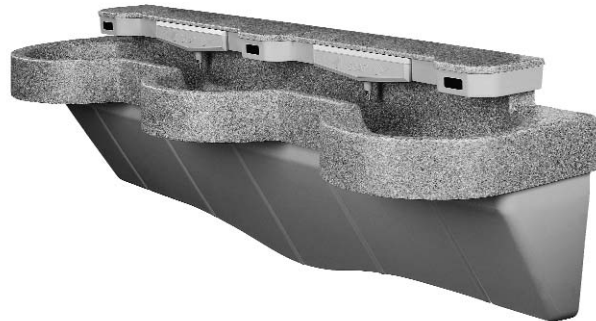

Model SS-3/IR/WHTAS  
Shown with optional  
liquid soap dispensers

## TAS Mounting Height Options

### Juvenile Height

#### Texas Accessibility Standards Compliant

The Wall-Hung TAS Express® complies with all Texas Accessibility Standards (TAS) guidelines on reaches, clearances and operation for juvenile users. To comply with TAS for grades Pre-K thru 5 or 6, the rim-height of the Wall-Hung TAS Express® bowl must be 30" maximum above finished floor. For grades 6 thru 8 or 9, the unit must be mounted with a rim height of 32" maximum above finished floor. Always check local codes for compliance.

## Standard Equipment

Bowl with three lavatories, pedestal, stainless steel mounting frame (as described above), and the following fittings: P-trap; tailpiece; two flexible stainless steel supply connections; and Vematherm thermostatic mixing valve with combination stop, strainer, check valves, and 110/24 VAC plug-in transformer (model SS-3/IR/WHTAS only). Single valve control boxes are only included in Model SS-3/BIR/WHTAS.

## Activation Controls

### Infrared Sensor (SS-3/IR/WHTAS)

Each of the streamformers is controlled by a separate solenoid valve. Hands placed within the bowl are detected by an infrared sensor module which activates a flow of tempered water from one streamformer. Shut-off is automatic after hands are removed from the detection area.



P.O. Box 309, Menomonee Falls, WI 53052-0309  
Phone 1-800-BRADLEY FAX 262-251-5817  
http://www.bradleycorp.com  
Technical Information Fax Service: 1-800-BRADFAX

**Express® Lavatory System — SS-Series  
TAS Compliant**

Model SS-3/IR/WHTAS  
Model SS-3/AST/WHTAS  
Model SS-3/BIR/WHTAS  
Model SS-3/TT/WHTAS

**PLUMBING FIXTURES  
TECHNICAL DATA**

Dimensions shown in parentheses are millimeters.

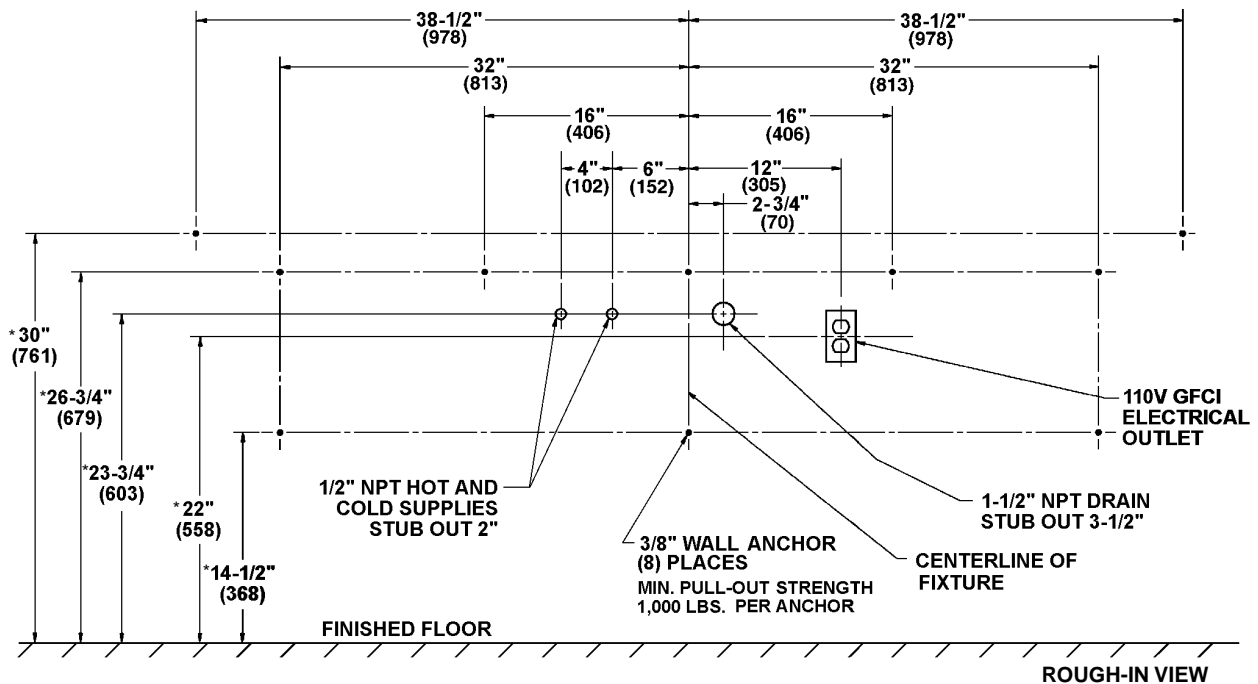
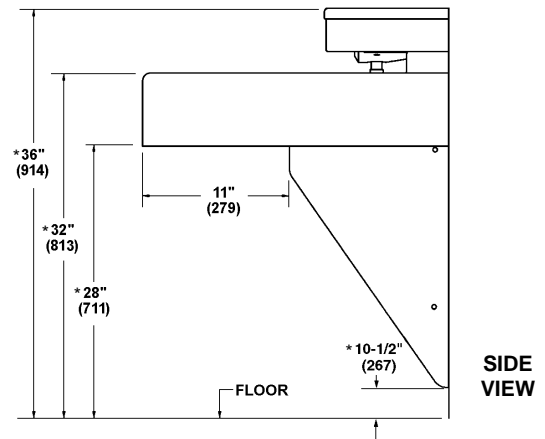
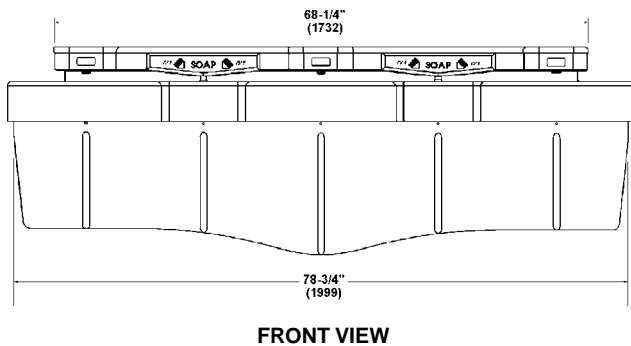
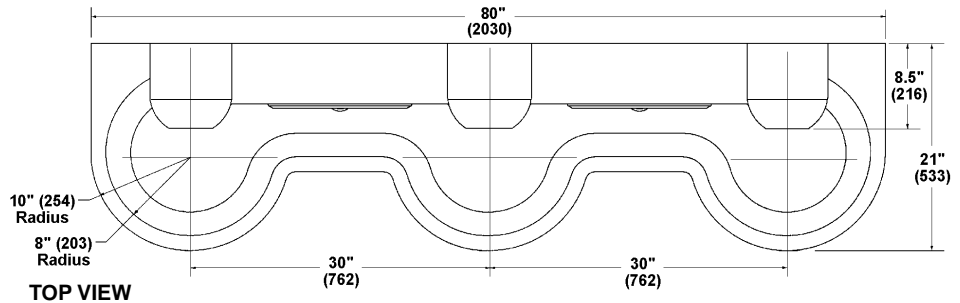

\* Subtract 2" from all vertical Dimensions for TAS Juvenile Height Grades Pre-K thru 5 or 6 Mounting.

Bradley Corporation reserves the right to make changes in design and material without formal notice and without incurring obligation. Verify all rough-in dimensions prior to installation.

# Express® Lavatory System — SS-Series Texas Accessibility Standards Compliant

- Model SS-3/IR/WHTAS** (Wall-Hung w/ Infrared Control)  
**Model SS-3/AST/WHTAS** (Wall-Hung w/ Air Valve Metering)  
**Model SS-3/BIR/WHTAS** (Wall-Hung w/Battery Operated Infrared Control)  
**Model SS-3/TT/WHTAS** Wall-Hung w/ Touch Time™ Metering)

The infrared sensor uses a conical shaped transmitting beam, having a detection area adapted to, but not exceeding the bowl perimeter. The detection area projects forward 15° to each side and 15° below horizontal. The adaptive infrared sensor automatically adapts to the bowl after power is turned on.

The infrared sensor is not affected by varying color tones or darkness. Direct sunlight or bright washroom lights will not activate the system. Infrared models also include solenoid valves and a low voltage transformer as standard equipment:

- Solenoid - 24V, 50/60 Hz, 3/8" NPT. Few moving parts, and resistant to most chemicals, minerals, and impurities often present in municipal water supplies.
- Low Voltage Transformer - Class II UL/CSA listed, 110/24 VAC plug-in transformer. Plugs into a standard GFCI electrical outlet.

## Air Valve Hand Control (SS-3/AST/WHTAS)

Each push-button pneumatically actuates a non-hold-open, air metering, single temperature valve with field adjustable timing from 0-45 seconds. Factory preset at 10 seconds. Each push-button activates one valve which, in turn, activates one station (streamformer).

## Battery Operated Infrared Sensor (Model SS-3/BIR/WHTAS)

Each battery powered sensor uses a zone-focused infrared transmitting beam, creating a large detection area not exceeding the bowl perimeter. The sensor is not affected by varying skin tones or darkness. When hands enter the detection area, the sensor starts water flow by opening the valve electronically. When hands leave the detection area, the sensor stops the flow of water by closing the valve.

The 9-volt DC, electronically activated, motor driven valve has few moving parts providing reliable operation that is unaffected by most chemicals and minerals often present in municipal water supplies. The valve is located inside the operation box assembly along with (6) double-A alkaline batteries.

- Single Valve Control Box – Power consumption of 50 micro amps per valve. Control box is constructed of sturdy watertight plastic.

## Touch Time™ Metering Control (Model SS-3/TT/WHTAS)

Each low voltage pushbutton actuates a non-hold-open, slow closing anti-hammer solenoid valve that is timed from an electronic potted assembly. Each pushbutton activates one valve, which, in turn, activates one station (streamformer). Touch Time™ controls water flow at each station through the use of solid state, digital circuitry. Timing is electronically controlled at 15 seconds.

## Sample Specification

### Express® Model SS-3/IR/WHTAS

The modular multiple lavatory system shall be Bradley Wall-Hung TAS Express® Model No. SS-3/IR/WHTAS. Multiple lavatory system shall provide three hand washing stations, with the centerline of each station located on 30" centers, perpendicular to the mounting wall. Each hand washing station shall comply with Texas Accessibility Standards for juvenile users.

- bowl and sprayhead cover material for each station shall be constructed of NAHB Certified Terreon, complying with ANSI Z124.3, Z124.6 and ANSI/ICPA SS-1-2001. Bowl and sprayhead cover finish shall be decorative stone.
- bowl color: Empire Gray (other colors available)
- lavatory stations shall be secured to a rigid base concealing all supply and waste connections.
- base shall support all hand washing stations to ANSI Z124.3 load ratings. Each hand washing station shall have a streamformer served by an independent solenoid valve and actuated by an infrared sensing module with a single conical beam not exceeding the bowl perimeter. Each sensor shall have a 2-3 second turn-off delay; and automatic shut-off after 30-45 seconds of continuous operation.
- lavatory system shall include all waste and supply connections to wall, and thermostatic mixing valve with stop, strainer, and check valves.

### Express® Model SS-3/AST/WHTAS

The modular multiple lavatory system shall be Bradley Wall-Hung TAS Express® Model No. SS-3/AST/WHTAS. Multiple lavatory system shall provide three hand washing stations, with the centerline of each station located on 30" centers, perpendicular to the mounting wall. Each hand washing station shall comply with Texas Accessibility Standards for juvenile users.

- bowl and sprayhead cover material for each station shall be constructed of NAHB Certified Terreon, complying with ANSI Z124.3, Z124.6 and ANSI/ICPA SS-1-2001. Bowl and sprayhead cover finish shall be decorative stone.
- bowl color: Empire Gray (other colors available)
- lavatory stations shall be secured to a rigid base concealing all supply and waste connections.
- base shall support all hand washing stations to ANSI Z124.3 load ratings. Each hand washing stations shall have a streamformer served by an independent air metering valve which is actuated by a pushbutton.
- lavatory system shall include all waste and supply connections to wall, and thermostatic mixing valve with stop, strainer, and check valves.

# Express® Lavatory System — SS-Series Texas Accessibility Standards Compliant

- Model SS-3/IR/WHTAS (Wall-Hung w/ Infrared Control)
- Model SS-3/AST/WHTAS (Wall-Hung w/ Air Valve Metering)
- Model SS-3/BIR/WHTAS (Wall-Hung w/Battery Operated Infrared Control)
- Model SS-3/TT/WHTAS (Wall-Hung w/ Touch Time™ Metering)

## Express® Model SS-3/BIR/WHTAS

The modular multiple lavatory system shall be Bradley Wall-Hung TAS Express® Model No. SS-3/BIR/WHTAS. Multiple lavatory system shall provide three hand washing stations, with the centerline of each station located on 30" centers, perpendicular to the mounting wall. Each hand washing station shall comply to Texas Accessibility Standards for juvenile users.

- bowl and sprayhead cover material for each station shall be constructed of NAHB Certified Terreon, complying with ANSI Z124.3, Z124.6 and ANSI/ICPA SS-1-2001. Bowl and sprayhead cover finish shall be decorative stone.
- bowl color: Empire Gray (other colors available)
- lavatory stations shall be secured to a rigid base concealing all supply and waste connections.
- base shall support all hand washing stations to ANSI Z124.3 load ratings. Each hand washing station shall have a streamformer served by an independent control box and actuated by an infrared sensing module with a single conical beam not exceeding the bowl perimeter. Each sensor shall have a 1-2 second turn-off delay; and automatic shut-off after approximately 90 seconds of continuous operation.
- lavatory system shall include three single valve control boxes, all waste and supply connections to wall, and thermostatic mixing valve with stop, strainer, and check valves.

## Express® Model SS-3/TT/WHTAS

The modular multiple lavatory system shall be Bradley Wall-Hung TAS Express® Model No. SS-3/TT/WHTAS. Multiple lavatory system shall provide three hand washing stations, with the centerline of each station located on 30" centers, perpendicular to the mounting wall. Each hand washing station shall comply with Texas Accessibility Standards for juvenile users.

- bowl and sprayhead cover material for each station shall be constructed of NAHB Certified Terreon, complying with ANSI Z124.3, Z124.6 and ANSI/ICPA SS-1-2001. Bowl and sprayhead cover finish shall be decorative stone.
- bowl color: Empire Gray (other colors available)
- lavatory stations shall be secured to a rigid base concealing all supply and waste connections.
- base shall support all hand washing stations to ANSI Z124.3 load ratings. Each hand washing stations shall have a streamformer served by a pushbutton and independent Touch Time™ electronic metering valve.
- lavatory system shall include all waste and supply connections to wall, and thermostatic mixing valve with stop, strainer, and check valves.

## Models

Model No.	Description
<input type="checkbox"/> SS-3/IR/WHTAS	Express® Lavatory System w/Infrared Control (Wall-Hung / TAS Compliant)
<input type="checkbox"/> SS-3/AST/WHTAS	Express® Lavatory System w/Air Valve Metering (Wall-Hung / TAS Compliant)
<input type="checkbox"/> SS-3/BIR/WHTAS	Express® Lavatory System w/Battery Operated Infrared Control (Wall-Hung / TAS Compliant)
<input type="checkbox"/> SS-3/TT/WHTAS	Express® Lavatory System w/Touch Time™ Metering Valve (Wall-Hung / TAS Compliant)

## Standard Selections

### Soap Dispenser (Select One):

- LSD Liquid Soap Dispenser
- NSD No Soap Dispenser

### Water Supply (Select One):

- TMA Vernatherm Thermostatic Mixing Assembly (Hot and Cold Supplies)
- TL Single Tempered Line

### Color of Terreon® Bowl/Sprayhead Cover (Select One):

- |   |  |
|---|--|
| <input type="checkbox"/> E-GRAY Empire Gray     | <input type="checkbox"/> DS-WHT Designer White |
| <input type="checkbox"/> BONE Mesa Bone         | <input type="checkbox"/> SPHR Sapphire         |
| <input type="checkbox"/> O-GRN Oasis Green      | <input type="checkbox"/> EMRLD Emerald         |
| <input type="checkbox"/> S-BLU Sierra Blue      | <input type="checkbox"/> JADE Jade             |
| <input type="checkbox"/> M-RED Mojave Red       | <input type="checkbox"/> GRAPH Graphite        |
| <input type="checkbox"/> PEP-WHT Peppered White | <input type="checkbox"/> ONYX Onyx             |
| <input type="checkbox"/> SAND Sandtrap          | <input type="checkbox"/> LANNON Lannonstone    |
| <input type="checkbox"/> CHAR Charcoal Gray     | <input type="checkbox"/> COBBLE Cobblestone    |
| <input type="checkbox"/> WHT-SAND White Sand    | <input type="checkbox"/> FIESTA Fiesta         |

### Color of Access Panel/Sprayhead Body (Select One):

- GRAY Gray
- PUTTY Putty
- COAL Coal

Document No. 1070

This information is subject to change without formal notice.  
0902BLCE (4 Pages Total)



P.O. Box 309, Menomonee Falls, WI 53052-0309  
Phone 1-800-BRADLEY FAX 262-251-5817  
http://www.bradleycorp.com  
Technical Information Fax Service: 1-800-BRADFAX