

Minimix™ MM2 Temperature Select Valve

Model S01-515

- Allows User Control of Water Temperature
- Brass and Chrome-Plated Brass Construction
- One-Year Warranty

Specifications

User Operation

The knob on the operating stem operates the valve.

Materials

The valve body is constructed of brass. The slider mechanism in the valve's interior is made of Celcon™. The check valves are polypropylene with Buna-N o-ring seals. The knob is chrome-plated brass.

Mounting

The maximum counter thickness for mounting is 1-1/4" (32mm).

Standard Equipment

Flow/Control Rate

User Control MM2 has a maximum flow rate of 3.0 GPM at 30 PSI.

Valve Knob

The valve knob rests on the lavatory counter top. By turning the knob on the operating stem, the ratio of hot and cold water made available to the outlet varies, altering the temperature flowing out of the valve.

Eccentric Pin

The eccentric pin on the end of the operating stem drives the slider which regulates the amount of water flow by opening or closing the cross-flow check valves.

Sample Specifications

The user temperature control valve for the water supply made available to outlet shall be (S01-515) Bradley Model MM2 Minimix Valve. The valve shall be constructed of brass with a Celcon™ slider mechanism and chrome-plated brass handle. Check valves shall be constructed of polypropylene with Buna-N o-ring seals.

- User to control water temperature with a control knob to rest on counter top
- Maximum flow rate of MM2 shall be 3.0 GPM @ 30 PSI

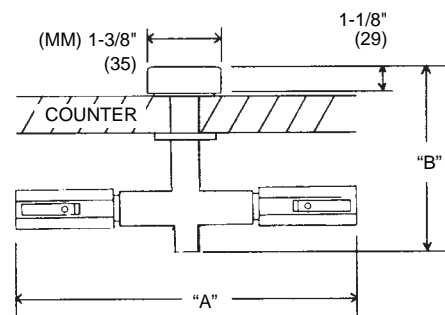

| | MM2 |
|-------|--------------|
| "A" | 9-1/4" (235) |
| "B" | 4-3/8" (111) |
| DEPTH | 1-5/8" 941) |

MAX. COUNTER DEPTH = 1-1/4" (32)

MODELS – Faucet Only

| Part No. | Model/Description |
|----------------------------------|---|
| <input type="checkbox"/> S01-515 | MM2, User-Adjustable Mixing Valve, High Flow, 3 GPM |

Document No. 3070

This information is subject to change without formal notice.
0203BLCE (1 Page Total)



P.O. Box 309, Menomonee Falls, WI 53052-0309
Phone 1-800-BRADLEY FAX 262-251-5817
<http://www.bradleycorp.com>
Technical Information Fax Service: 1-800-BRADFAX