

- Complies with American National Standard Z358.1-2009
- Easily Mounts to Wall
- Galvanized Steel Protected with BradTect® Safety Yellow Coating
- Universal Identification Sign and Inspection Tag Included
- Full, One-Year Warranty
- Patent Pending

### Specifications

Impact-resistant plastic shower head is colored bright yellow for high visibility in emergency situations. Also available in corrosion resistant stainless steel. Shower pull rod is stainless steel. Galvanized steel piping is additionally protected with BradTect® safety yellow coating. Model S19-120SS is all stainless steel construction.

*Drench shower is designed to accommodate standard 8' ceiling height. ANSI Z358.1 compliant drench showers are mounted between 82"-96" from the lower edge of the showerhead or shroud to the floor.*

#### cUPC Approved:

The Emergency Fixtures are certified to comply with the requirements of the Uniform Plumbing Code and the National Plumbing Code of Canada by the International Association of Plumbing and Mechanical Officials (IAPMO).

*This plumbing fixture is not intended to dispense water for human consumption through drinking or for preparation of food or beverages.*

Model	Description
<input type="checkbox"/> S19-120	Drench Shower w/Horizontal Supply <b>Plastic Showerhead</b>
<input type="checkbox"/> S19-120A	Drench Shower w/Horizontal Supply <b>Plastic Showerhead-Stainless Steel Shroud</b>
<input type="checkbox"/> S19-120SS	Drench Shower w/Horizontal Supply <b>All-Stainless Steel Fixture</b>
<input type="checkbox"/> S19-2100	Navigator EFX25 - Emergency Thermostatic Mixing Valve

**Recommended Option:**  
 Navigator S19-2100 EFX25  
 Emergency Thermostatic Mixing Valve

**NAVIGATOR**

Satisfies ANSI Z358.1-2009 tepid water requirements.

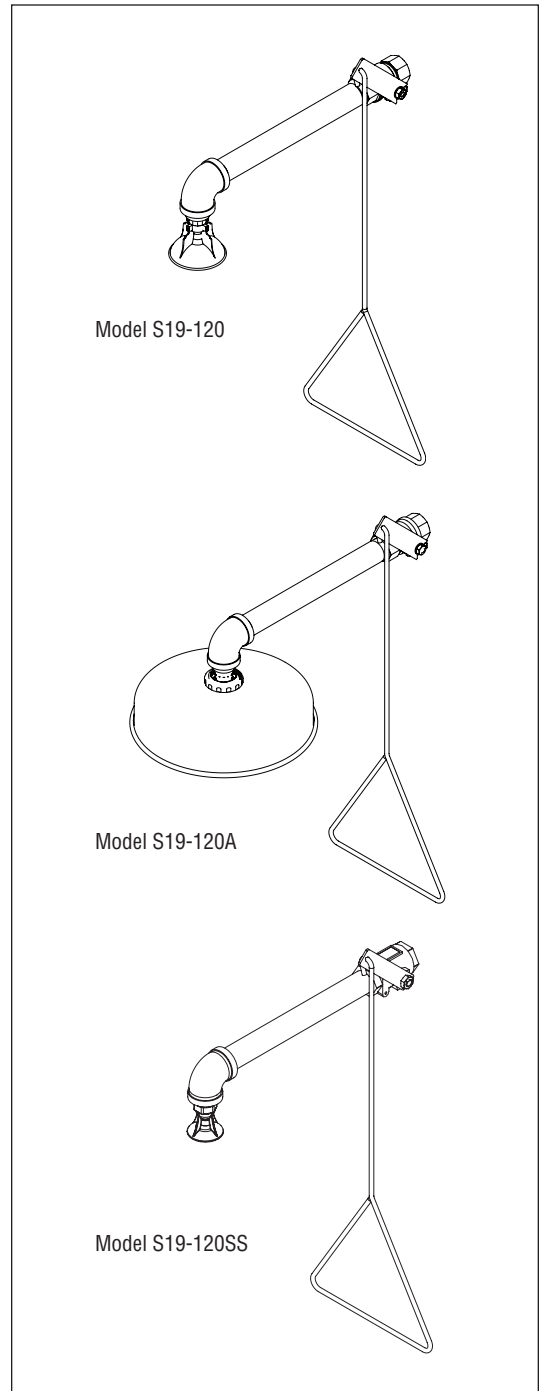

### Standard Equipment

#### SpinTec™ Showerhead

Standard showerhead is 3.1" (78.7mm) diameter highly visible yellow impact-resistant plastic (Model S19-120A includes a 10 $\frac{3}{4}$ " [273mm] diameter corrosion-resistant stainless steel shroud). High performance corrosion-resistant stainless steel showerhead measures 2" (51mm) in diameter (Model S19-120SS only). SpinTec drench showerhead features integral 26 GPM flow control, conserving water and helping to accurately size your tepid water system.

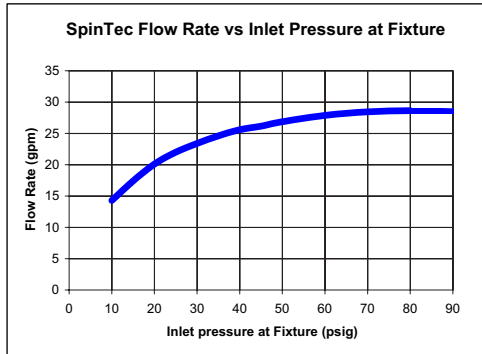

#### Valve

Chrome-plated brass 1" NPT stay-open ball valve, operated by stainless steel pull rod with triangular handle. Model S19-120SS is all stainless steel.

#### Pipe and Fittings

1/4" galvanized steel with BradTect® safety yellow coating. S19-120SS is all stainless steel.

#### Water Supply

1" NPT Horizontal.



*Local codes may require the installation of a backflow prevention valve to complete proper installation. Compliance with local codes is the responsibility of the installer. Valve must be tested annually to verify that it is functioning properly. Backflow prevention valves are not included with the fixture and may be supplied by the contractor or purchased from Bradley Corporation.*

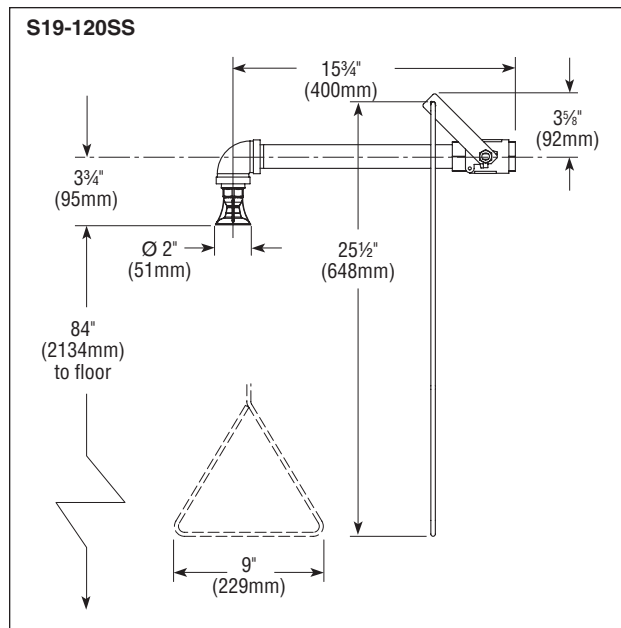
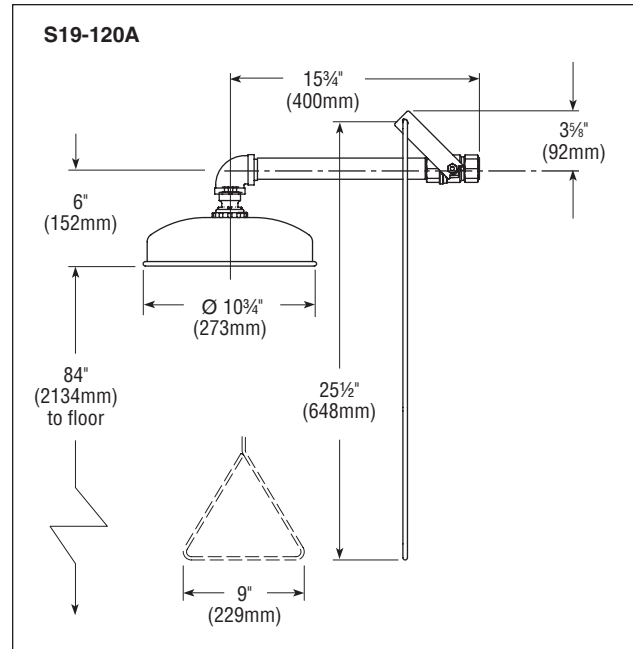
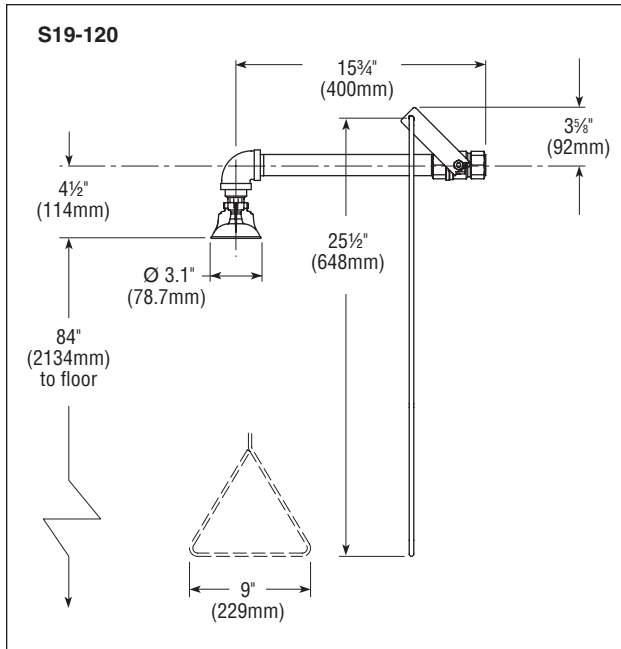

All dimensions assume standard thread engagement. Variations in manufacturing allow for +/- 1/8" (3mm) per threaded joint. To find the tolerance of a dimension, add the number of thread joints in between a dimension and multiply it by 1/8" (3mm).