



S19-125BF, S19-125FMBF, S19-125SBF, S19-125SFMBF Barrier-Free Recessed Drench Shower

- Complies with American National Standard Z358.1-2009
- Fully Recessed Handle (Models S19-125BF and S19-125FMBF)
- Sturdy One-Piece Cabinet for Quick and Easy Installation
- Full, One-Year Warranty
- Patent Pending



Specifications

Barrier-free design makes this shower and eyewash fully accessible to people with physical disabilities. This unit is designed to accommodate areas where space considerations are a concern. Such areas may include, but are not limited to, laboratories, hospitals, and schools. Recessed hand handle models (S19-125BF and S19-125FMBF) do not break the plane of the wall. This ensures no obstructions protrude from the wall at any time. Shower valve activates when handle is pushed downward. No tight pinching or grasping is required to activate. Showerhead is designed for varying water supply pressures of 30–90 PSI ensures a minimum flow of 20 GPM for ANSI compliance.

- ANSI Z358.1 compliant drench showers are mounted between 82"–96" from the lower edge of the showerhead or shroud to the floor.**
- This plumbing fixture is not intended to dispense water for human consumption through drinking or for preparation of food or beverages.**

Recommended Option:
 Navigator S19-2100 EFX25
 Emergency Thermostatic Mixing Valve



NAVIGATOR

Satisfies ANSI Z358.1-2009
 tepid water requirements.

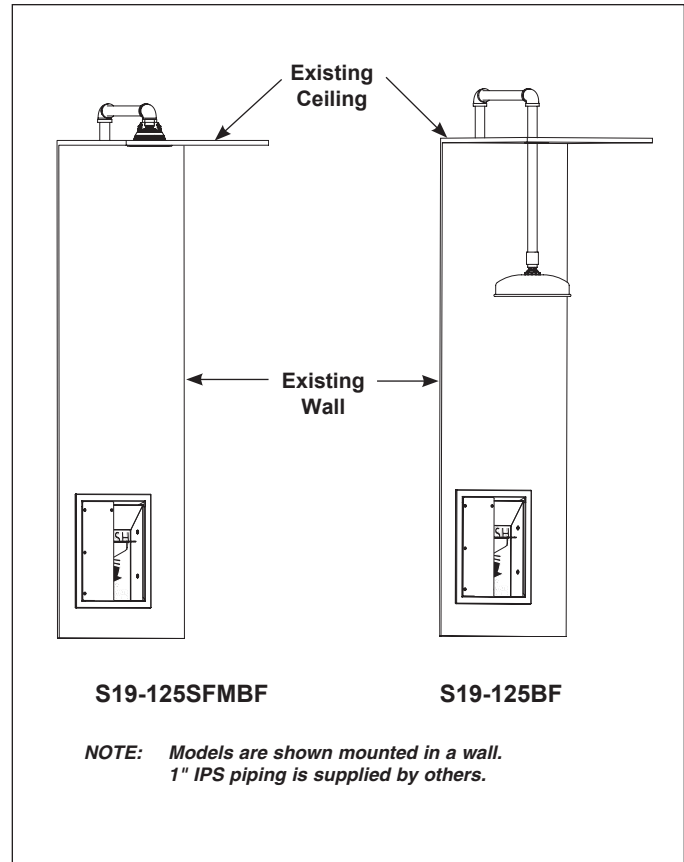

Model	Description
<input type="checkbox"/> S19-125BF	Barrier-Free Recessed Drench Shower with Recessed Handle and Extended Showerhead
<input type="checkbox"/> S19-125FMBF	Barrier-Free Recessed Drench Shower with Recessed Handle and Flush-Mounted Showerhead
<input type="checkbox"/> S19-125SBF	Barrier-Free Recessed Drench Shower with Surface-Mounted Handle (Cover Plate Included) and Extended Showerhead
<input type="checkbox"/> S19-125SFMBF	Barrier-Free Recessed Drench Shower with Surface-Mounted Handle (Cover Plate Included) and Flush-Mounted Showerhead
<input type="checkbox"/> S19-2100	Navigator EFX25 - Emergency Thermostatic Mixing Valve

Standard Equipment

Cabinet and Optional Cover Plate

Stainless Steel. Optional cover plate for models with surface-mounted handle.

SpinTec™ Showerhead

3.1" (78.7mm) diameter highly visible yellow impact-resistant plastic with optional 10 $\frac{3}{4}$ " (273mm) diameter corrosion-resistant stainless steel shroud. SpinTec drench showerhead features integral 26 GPM flow control, conserving water and helping to accurately size your tepid water system.

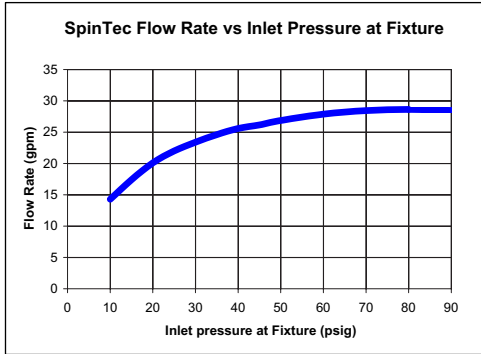

Shower Valve

Chrome-plated brass 1" NPT stay-open ball valve. Hand operated by a black powder-coated stainless steel handle when pushed downward.

Pipe and Fittings

1" brass and copper components.

Water Supply

1" NPT. Piping is supplied by others.

Installation

A rough wall opening of 10 $\frac{1}{4}$ "W x 14 $\frac{1}{4}$ "H x 4"D is required for Models S19-125BF and S19-125FMBF. Frame is integral to the Models S19-125BF and S19-125FMBF cabinets. Secure unit to framing with screws (supplied by installer) at holes provided. A rough wall opening of 6"W x 10"H x 4"D is required for Models S19-125SBF and S19-125SFMBF.

S19-125BF Cabinet Side View

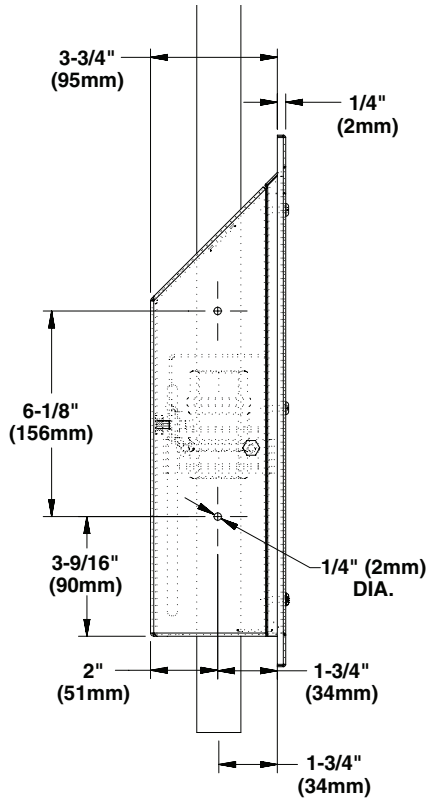

S19-125BF Cabinet Front View

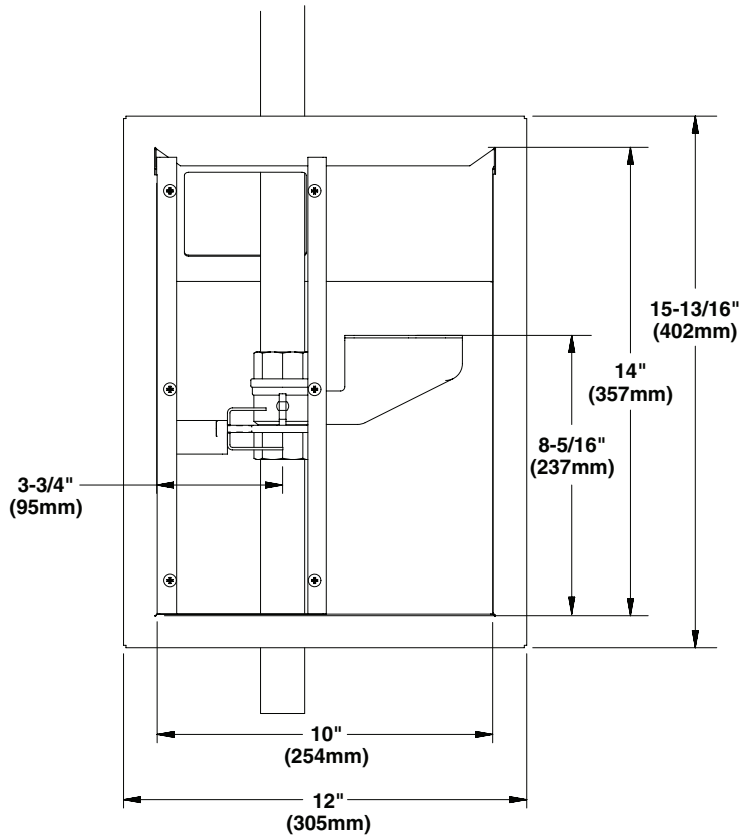

S19-125BF Cabinet Bottom View

