

Pedestal-Mounted Eye/Face Wash Fixture

Model S19-210FW

Model S19-210Y (Shown)

Model S19-210YF

- Complies with American National Standard Z358.1-2004
- Galvanized Steel Pipe and Waste Tee with Floor Flange is Protected with BRADTECT™ Safety Yellow Coating
- Universal Identification Sign and Inspection Tag Included
- Full, One-Year Warranty

Specifications

Unit design saves space and fits easily into any work environment. Eyewash operates quickly by a large, highly visible push handle or foot pedal. Safe, steady water flow under varying water supply conditions from 30-90 PSI is assured by integral flow control in the sprayhead assembly.

UPC and cUPC Approved:

The Emergency Fixtures are certified to comply with the requirements of the Uniform Plumbing Code and the National Plumbing Code of Canada by the International Association of Plumbing and Mechanical Officials (IAPMO).

Construction

Impact resistant plastic eyewash bowl is colored bright yellow for high visibility in emergency situations or corrosion resistant stainless steel. Large push handle is operated by hand or stainless steel foot pedal. Galvanized steel pipe and waste tee with floor flange are additionally protected with BRADTECT™ safety yellow coating.

Standard Equipment

Eyewash Bowl

10" (254mm) diameter impact resistant plastic or stainless steel.

Eye/Face Wash Sprayhead

Twin perforated disc eye/face wash heads with protective pop-off sprayhead covers, operated by a large, highly visible safety yellow PVC push handle. Safe, steady water flow under varying water supply conditions is assured by a flow control for 30-90 PSI.

Valve

Chrome-plated brass 1/2" IPS stay-open ball valve. Hand operated by a large, highly visible safety yellow PVC push handle or foot pedal.

Pipe and Fittings

Galvanized steel and waste tee with floor flange protected with BRADTECT™ safety yellow coating.

Waste

Dome-type strainer and 1-1/4" drain fitting furnished.

Water Supply

1/2" IPS.

Document No. 4245

This information is subject to change without formal notice.
© 2004 Bradley Corporation
8-18-2006 (2 Pages Total)

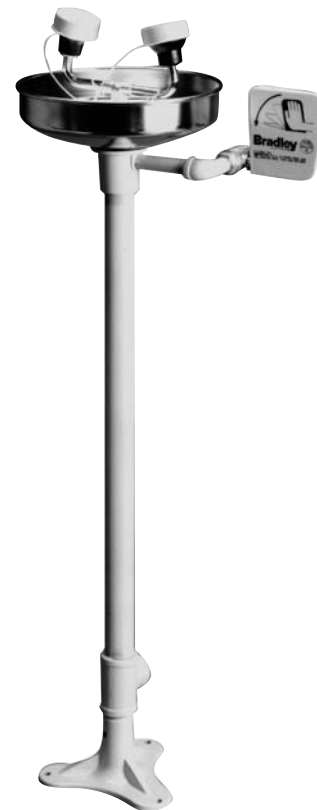

Recommended Option:

Navigator S19-2000 EFX8
Emergency Thermostatic Mixing Valve

NAVIGATOR

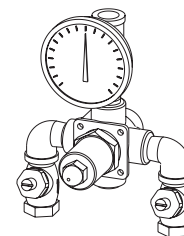

Satisfies ANSI Z358.1-2004
tepid water requirements.

Bradley 

P.O. Box 309, Menomonee Falls, WI 53052-0309
Phone 1-800-BRADLEY FAX 262-251-5817
Web Site: <http://www.bradleycorp.com>



SEI CERTIFIED
MODEL
Z358.1-2004

Pedestal-Mounted Eye/Face Wash Fixture

Model S19-210FW

Model S19-210Y (Shown)

Model S19-210YF

| MODEL | |
|------------------------------------|--|
| Model No. | Description |
| <input type="checkbox"/> S19-210FW | Pedestal-Mounted Eye/Face Wash Fixture-Plastic Bowl |
| <input type="checkbox"/> S19-210Y | Pedestal-Mounted Eye/Face Wash Fixture-Stainless Steel Bowl |
| <input type="checkbox"/> S19-210YF | Pedestal-Mounted Eye/Face Wash Fixture - Stainless Steel Bowl, Hand or Foot Operated |
| <input type="checkbox"/> S19-2000 | Navigator EFX8 – Emergency Thermostatic Mixing Valve |

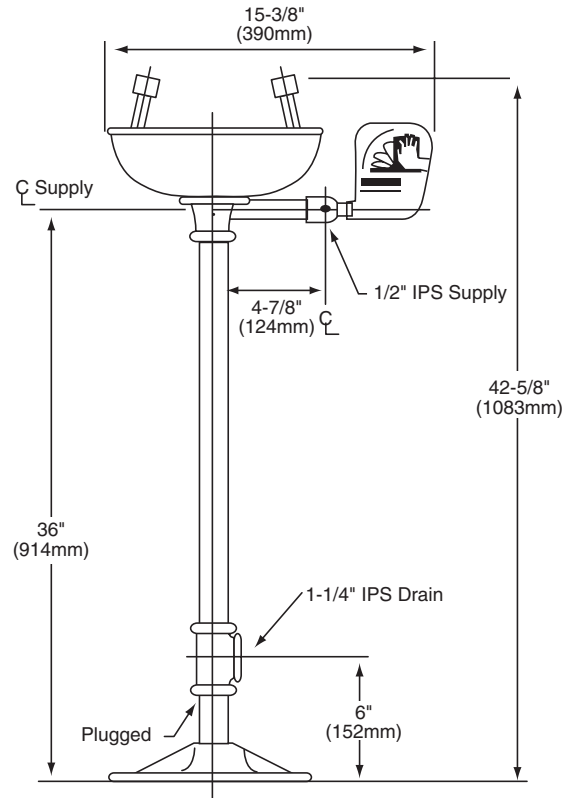

Document No. 4245

This information is subject to change without formal notice.
© 2004 Bradley Corporation
8-18-2006 (2 Pages Total)



P.O. Box 309, Menomonee Falls, WI 53052-0309
Phone 1-800-BRADLEY FAX 262-251-5817
Web Site: <http://www.bradleycorp.com>