

- Complies with American National Standard Z358.1-2009
- Galvanized Steel Pipe Protected with BradTect® Safety Yellow Coating
- Universal Identification Sign and Inspection Tag Included
- Wall Bracket Included
- Full, One-Year Warranty



Specifications

Unit design saves space and fits easily into any work environment. Eyewash operates quickly by a large, highly visible push handle. Safe, steady water flow under varying water supply conditions from 30–90 PSI is assured by integral flow control in the sprayhead assembly. NOTE: The ANSI Z358.1 standard requires an uninterrupted supply of flushing fluid at a minimum 30 PSI flowing pressure.

cUPC Approved

The Emergency Fixtures are certified to comply with the requirements of the Uniform Plumbing Code and the National Plumbing Code of Canada by the International Association of Plumbing and Mechanical Officials (IAPMO).



This plumbing fixture is not intended to dispense water for human consumption through drinking or for preparation of food or beverages.

Standard Equipment

Eyewash Bowl

10¾" (273mm) diameter corrosion-resistant stainless steel.

Standard Sprayhead Assembly

Chrome-plated brass sprayhead assembly with twin soft-flow eyewash heads and protective sprayhead covers. Safe, steady water flow under varying water supply conditions from 30–90 PSI is assured by integral flow control in the sprayhead assembly.

Valve

Chrome-plated brass ½" NPT stay-open ball valve. Hand operated by a large, highly visible stainless steel push handle.

Hinged Dust Cover

Stainless steel dust cover keeps contaminants, dust and debris from eye washing area.

Pipe and Fittings

Galvanized steel protected with BradTect® safety yellow coating.

Wall Bracket

Heavy-gauge sand cast aluminum protected with BradTect® safety yellow coating. Includes three clearance holes for mounting bracket onto wall (mounting hardware not included).

Waste

1¼" drain fitting, tailpiece and P-trap furnished.

Water Supply

½" NPT.

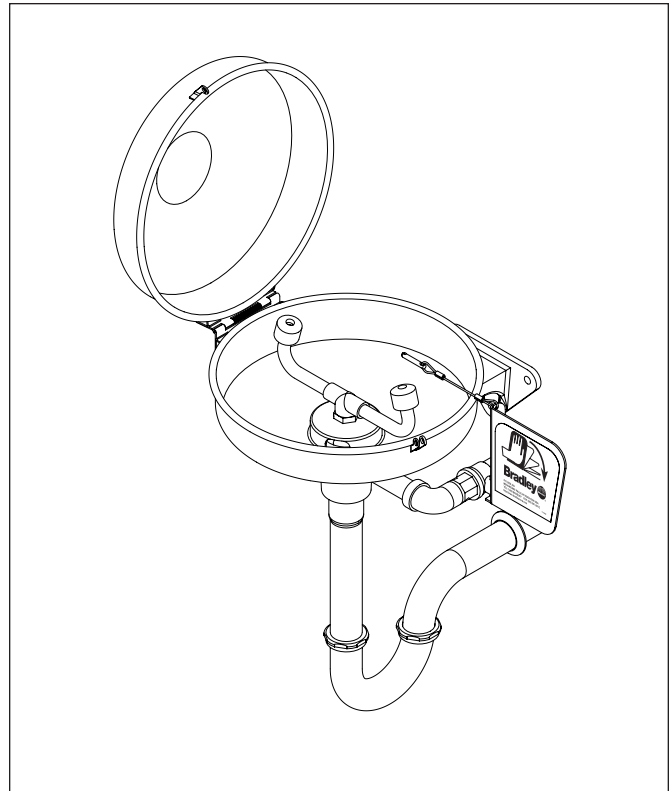

Model	Description
<input type="checkbox"/> S19-220DCPT	Wall-Mount Eyewash Unit with Hinged Dust Cover and P-Trap
<input type="checkbox"/> S19-2000	Navigator EFX8 – Emergency Thermostatic Mixing Valve

Recommended Option:

Navigator S19-2000 EFX8
Emergency Thermostatic Mixing Valve

NAVIGATOR

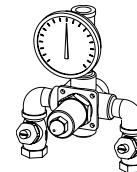

Satisfies ANSI Z358.1-2009
tepid water requirements.

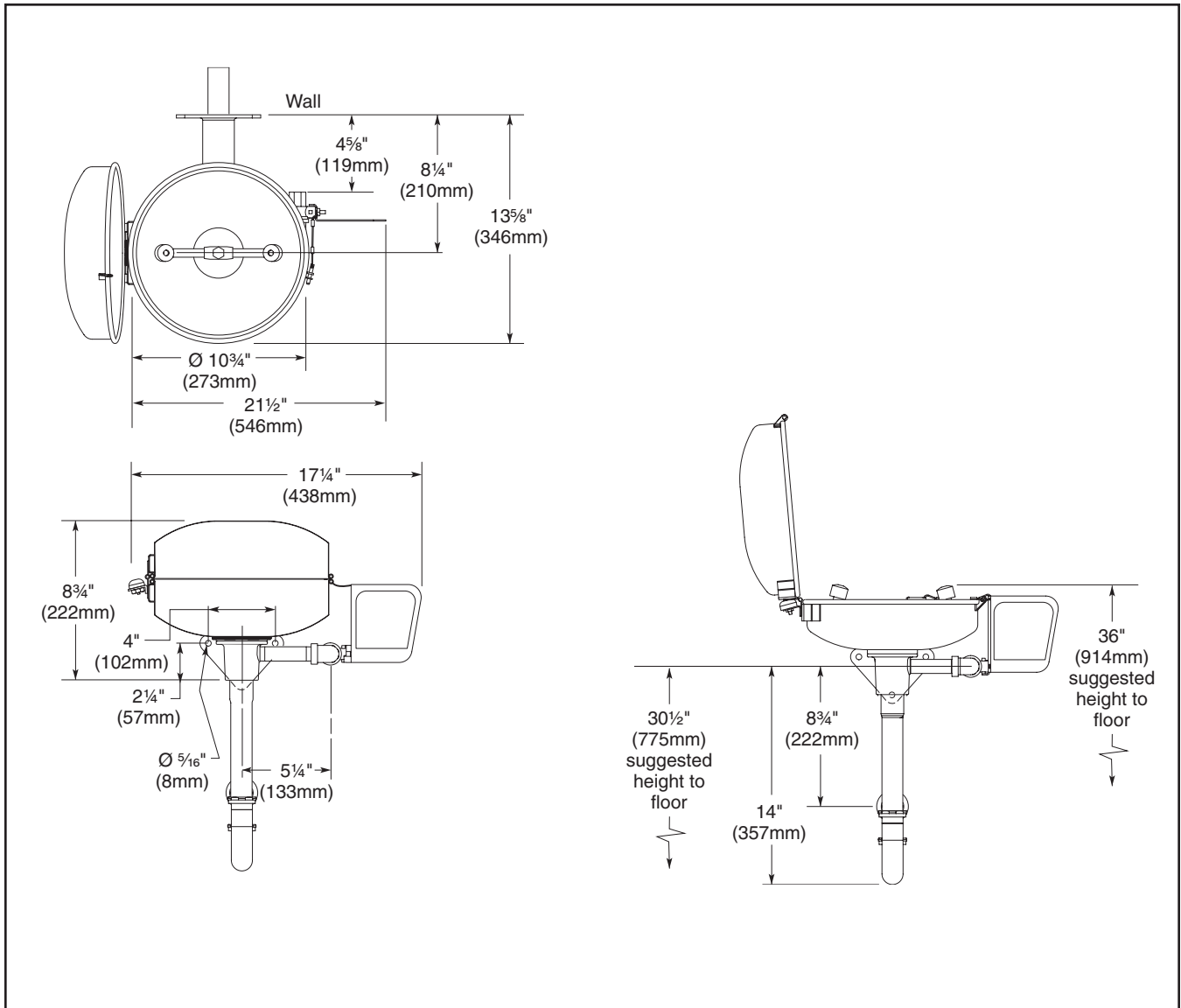

- Local codes may require the installation of a backflow prevention valve to complete proper installation. Compliance with local codes is the responsibility of the installer. Valve must be tested annually to verify that it is functioning properly. Backflow prevention valves are not included with the fixture and may be supplied by the contractor or purchased from Bradley Corporation.*
- All dimensions assume standard thread engagement. Variations in manufacturing allow for +/- 1/8" (3mm) per threaded joint. To find the tolerance of a dimension, add the number of thread joints in between a dimension and multiply it by 1/8" (3mm).*