

- Complies with American National Standard Z358.1-2009
- Galvanized Steel Protected with BradTect® Safety Yellow Coating or All Stainless Steel
- Universal Identification Sign and Inspection Tag Included
- Full, One-Year Warranty



Specifications

Unit design saves space and fits easily into any work environment. Eyewash operates quickly by a large, highly visible push handle. Safe, steady water flow under varying water supply conditions from 30–90 PSI is assured by integral flow control in the sprayhead assembly. NOTE: The ANSI Z358.1 standard requires an uninterrupted supply of flushing fluid at a minimum 30 PSI flowing pressure.

cUPC Approved:

The Emergency Fixtures are certified to comply with the requirements of the Uniform Plumbing Code and the National Plumbing Code of Canada by the International Association of Plumbing and Mechanical Officials (IAPMO).



This plumbing fixture is not intended to dispense water for human consumption through drinking or for preparation of food or beverages.

Standard Equipment

Eyewash Bowl

10" (254mm) diameter yellow impact-resistant plastic or 10¾" (273mm) diameter corrosion-resistant stainless steel.

Standard Sprayhead Assembly

Chrome-plated brass with twin soft-flow eyewash heads and protective sprayhead covers. Safe, steady water flow under varying water supply conditions from 30–90 PSI is assured by integral flow control in the sprayhead assembly.

Valve

Chrome-plated brass ½" NPT stay-open ball valve. Hand operated by a large, highly visible safety yellow PVC push handle.

Pipe and Fittings

Galvanized steel with BradTect® safety yellow coating.

Waste

1¼" drain fitting and tailpiece furnished.

Water Supply

½" NPT.

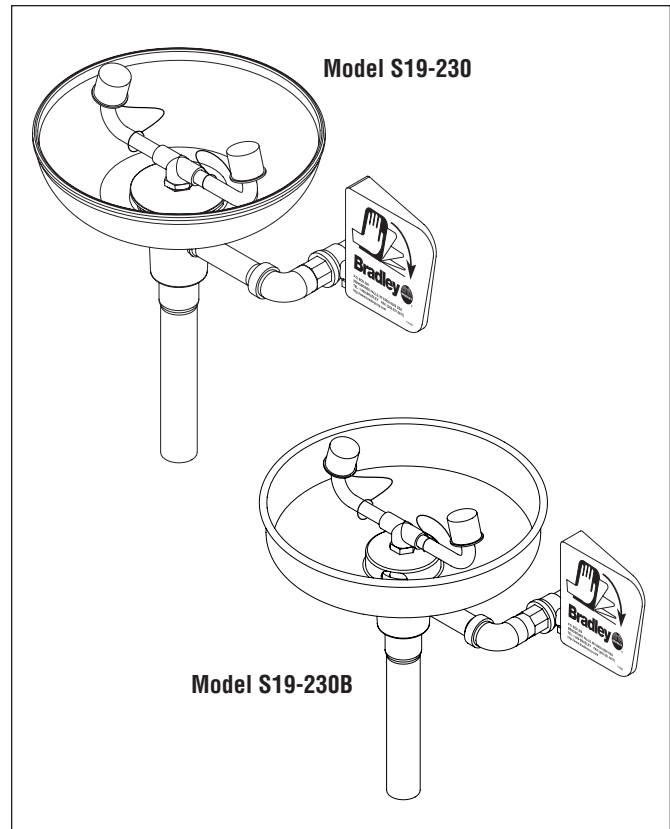

Recommended Option:
Navigator S19-2000 EFX8
Emergency Thermostatic Mixing
Valve

NAVIGATOR



Satisfies ANSI Z358.1-2009
tepid water requirements.

Model	Description
<input type="checkbox"/> S19-230	Unmounted Eyewash Unit - Plastic Bowl
<input type="checkbox"/> S19-230B	Unmounted Eyewash Unit - Stainless Steel Bowl
<input type="checkbox"/> S19-2000	Navigator EFX8 – Emergency Thermostatic Mixing Valve

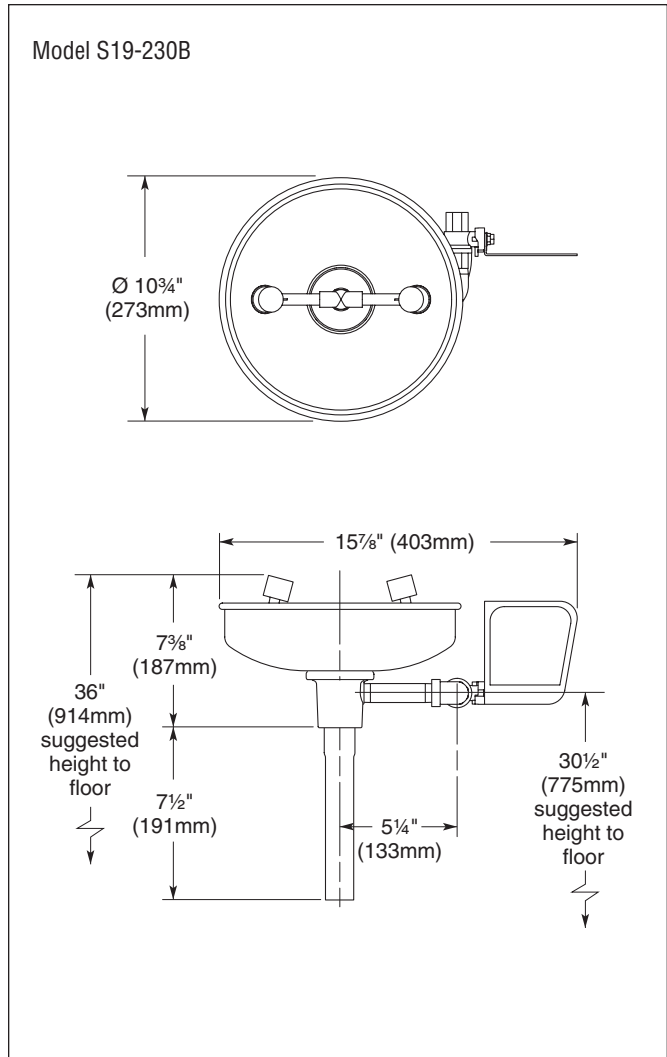
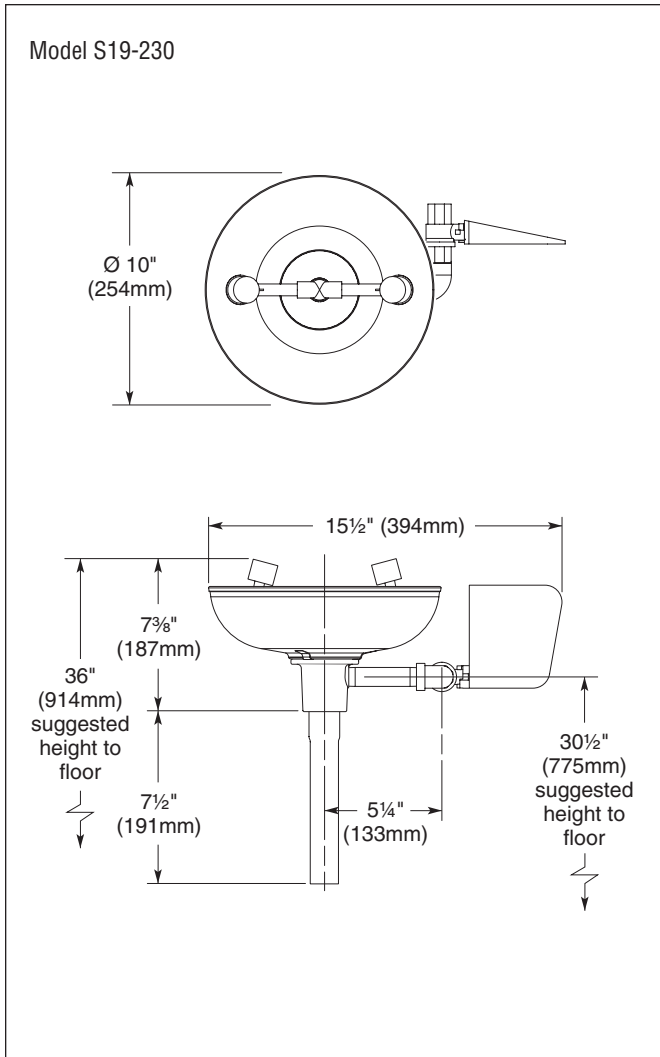

Local codes may require the installation of a backflow prevention valve to complete proper installation. Compliance with local codes is the responsibility of the installer. Valve must be tested annually to verify that it is functioning properly. Backflow prevention valves are not included with the fixture and may be supplied by the contractor or purchased from Bradley Corporation.

All dimensions assume standard thread engagement. Variations in manufacturing allow for $\pm \frac{1}{8}''$ (3mm) per threaded joint. To find the tolerance of a dimension, add the number of thread joints in between a dimension and multiply it by $\frac{1}{8}''$ (3mm).