

- Complies with American National Standard Z358.1-2009
- Right- and Left-Hand Mount Options
- Chrome-Plated Brass Pipe and Fittings
- Universal Identification Sign and Inspection Tag Included
- Full, One-Year Warranty

Specifications

Unit designed to rotate 360 degrees, save space and fit easily into any work environment. Eyewash operates quickly by a large, highly visible push handle. Safe, steady water flow under varying water supply conditions from 30–90 PSI is assured by integral flow control in the sprayhead assembly. NOTE: The ANSI Z358.1 standard requires an uninterrupted supply of flushing fluid at a minimum 30 PSI flowing pressure.

cUPC Approved:

The Emergency Fixtures are certified to comply with the requirements of the Uniform Plumbing Code and the National Plumbing Code of Canada by the International Association of Plumbing and Mechanical Officials (IAPMO).

This plumbing fixture is not intended to dispense water for human consumption through drinking or for preparation of food or beverages.

Construction

Pipe and fittings are chrome-plated brass. Includes right- or left-hand mount options.

Standard Equipment

Standard Sprayhead Assembly

Chrome-plated brass sprayhead assembly with twin soft-flow eyewash heads and protective sprayhead covers. Safe, steady water flow under varying water supply conditions from 30–90 PSI is assured by integral flow control in the sprayhead assembly.

Valve

Chrome-plated brass ½" NPT stay-open ball valve. Hand operated by a large, highly visible stainless steel push handle.

Pipe and Fittings

Chrome-plated brass.

Water Supply

½" NPT.

Recommended Option:
Navigator S19-2000 EFX8
Emergency Thermostatic Mixing
Valve

NAVIGATOR

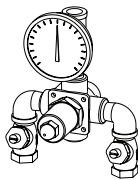

Satisfies ANSI Z358.1-2009
tepid water requirements.

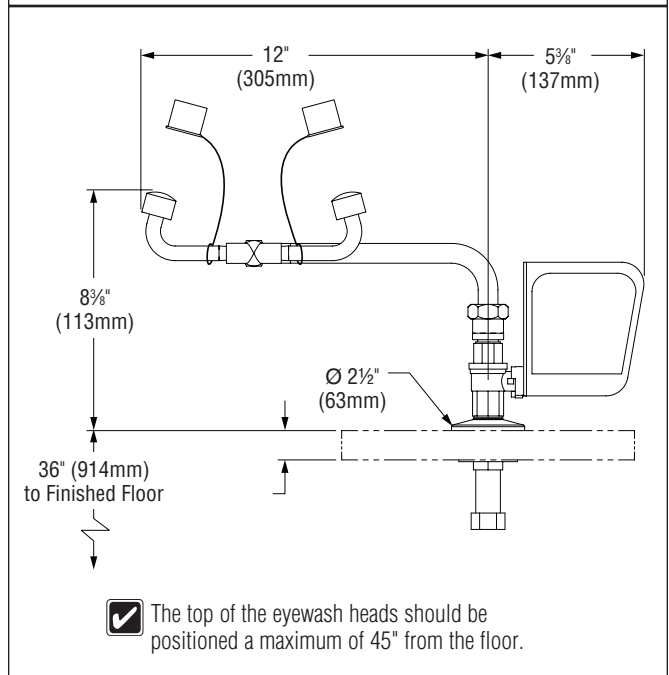
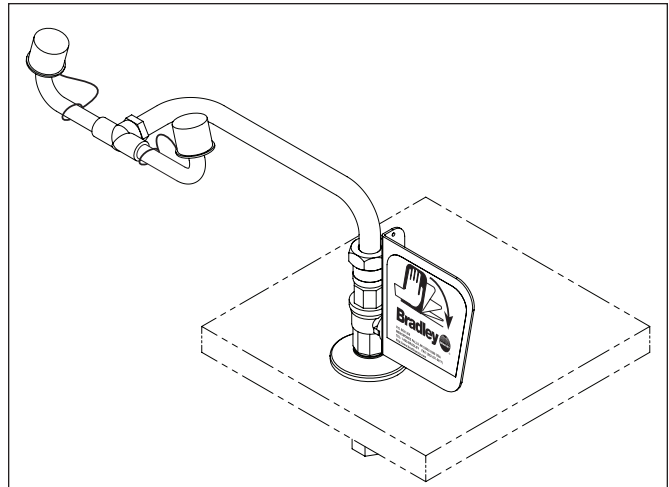

Model	Description
<input type="checkbox"/> S19-270B	Laboratory Application "Swing" Eyewash – Right-Hand Mount
<input type="checkbox"/> S19-270BL	Laboratory Application "Swing" Eyewash – Left-Hand Mount
<input type="checkbox"/> S19-2000	Navigator EFX8 - Emergency Thermostatic Mixing Valve