

S45-1964

- Impact-Resistant ABS Plastic Cover
- Highly Visible Yellow Color
- Suitable for "Barrier Free" Applications
- Durable Stainless Steel Hinge
- Full, One-Year Warranty

Specifications

The S45-1964 dust cover retrofits onto existing Bradley ABS plastic eyewash bowls. Cover protects entire bowl to keep contaminants, dust and debris from the eyewash area. Dust cover swings back and out of the way when push handle is activated.

The S45-1964 retrofit dust cover is constructed of impact-resistant ABS plastic. Hinge and handle linkage are constructed of corrosion-resistant stainless steel. Includes all components necessary for installation. Cover dimensions: 10 $\frac{3}{4}$ " (264mm) diameter x 3 $\frac{1}{2}$ " (89mm) high.

S45-2396

- Corrosion-Resistant Stainless Steel Bowl and Cover
- One-Step Activation Featuring a Pull-Pin Mechanism
- Suitable for "Barrier Free" Applications
- Durable Spring-Loaded Stainless Steel Hinge
- Full, One-Year Warranty

Specifications

The S45-2396 retrofit dust cover is constructed of corrosion-resistant brushed stainless steel. The stainless steel dust cover and spring-loaded hinge are welded to a stainless steel bowl for increased durability and vandal resistance. The stainless steel activation handle includes a tethered activation pin. The 1" diameter bumper is composed of soft black $\frac{1}{2}$ " thick rubber. Includes all components necessary for installation. Cover/bowl dimensions: 10 $\frac{3}{4}$ " (273mm) diameter x 6" (52mm) high when closed.

The S45-1964 dust cover retrofits onto existing Bradley ABS plastic eyewash bowls. Cover protects entire bowl to keep contaminants, dust and debris from the eyewash area. Dust cover swings back and out of the way when push handle is activated.

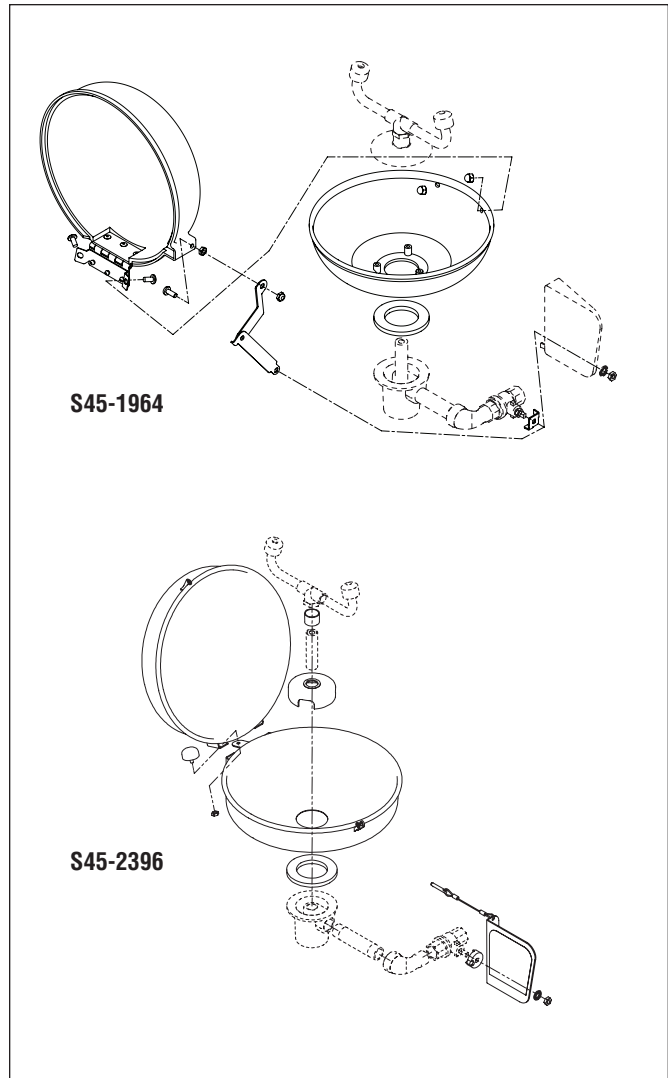

Model	Description
<input type="checkbox"/> S45-1964	Retrofit Dust Cover - Plastic
<input type="checkbox"/> S45-2396	Retrofit Dust Cover - Stainless Steel