

- Meets ANSI Z358.1-2004
- Reliable Liquid-Filled Thermostat with 10-Year Warranty
- Checkstops on Inlets
- Adjustable Set Point within Temperature Range
- Accurate Temperature Control to within $\pm 3^\circ$ F
- Built-in Cold Water Bypass, Assuring Cold Flow
- Positive Shutoff of Hot Supply When Cold Supply is Lost
- Easy Installation and Serviceability
- Dirt and Lime Resistant
- Dial Thermometer
- Factory Assembled and Tested
- Universal Mounting Capability
- Cabinet Features:
 - 18 Gauge Body & Door
 - Left-Hand Hinge
 - Cylinder Lock
 - Inlet/Outlet Knock-Out Holes for Mounting Flexibility
 - Stainless Steel or Baked White Enamel Finishes
 - Surface-Mounted or Recessed Style with Flange

Valve Specifications

Maximum Operating Pressure

125 PSI (860 kPa)

Maximum Inlet Temperature

180° F (82° C)

Recommended Inlet Temperature

120° F (49° C) – 140° F (60° C)

Temperature Range

Std. 65° F (18° C) to 95° F (35° C)

Set Point

85° F (29° C)

Flow Capacities – GPM (L/Min)

Model	Min. Flow	Pressure Drop – PSI (Bar)						
		5 (.5)	10 (1.0)	15 (1.5)	20 (2.0)	30 (2.5)	45 (3.0)	60 (4.0)
S19-2000	1.5 (5.5)	3.0 (13.5)	4.0 (19.0)	5.0 (23.5)	6.0 (27.0)	7.3 (30.5)	9.0 (33.5)	10.5 (38.5)
Cold Bypass Only		2.3 (10.5)	3.2 (14.5)	4.0 (18.0)	4.6 (21.0)	5.6 (23.5)	6.8 (25.5)	7.7 (29.5)

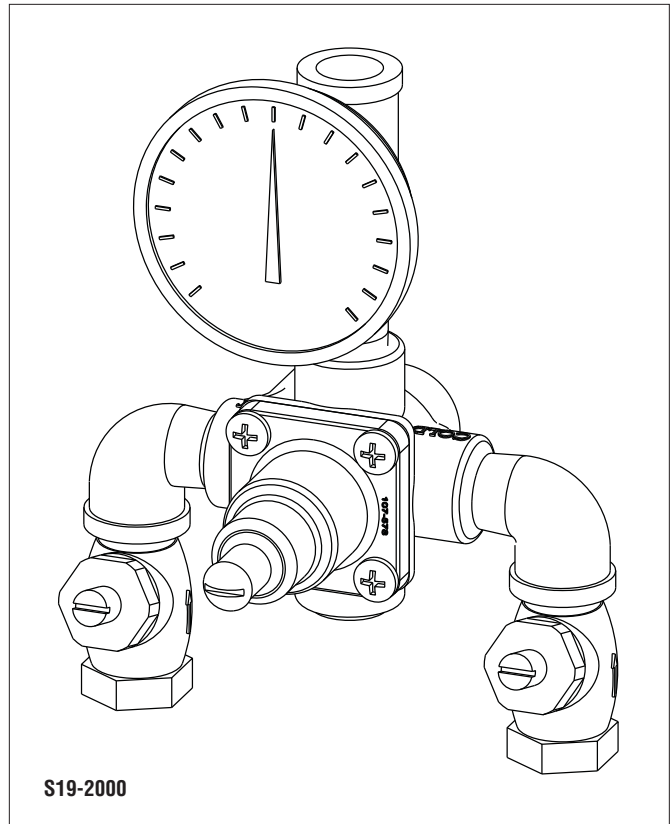

Optional Selections

Finish

- C** Chrome Plated

Cabinets

- SS** Surface Mount Stainless Steel
- RS** Recessed Stainless Steel
- SE** Surface Mount White Enamel
- RE** Recessed White Enamel
- W** Plexi-glass Window in Door

Engineer's Approval _____

Dimensions

(mm)

Front View

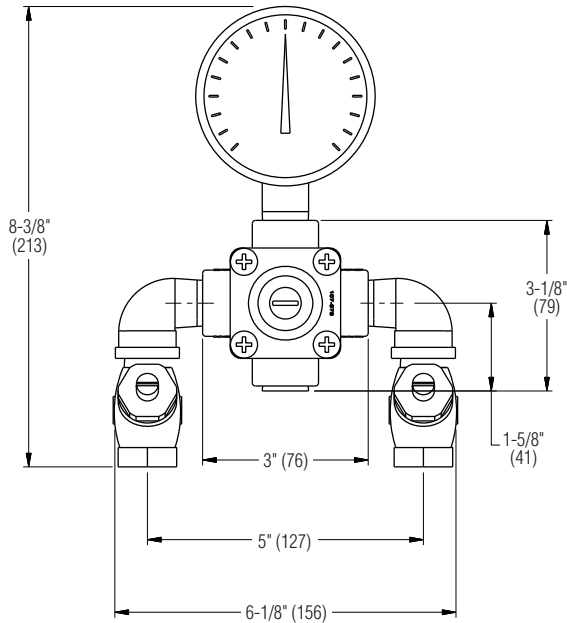

Side View

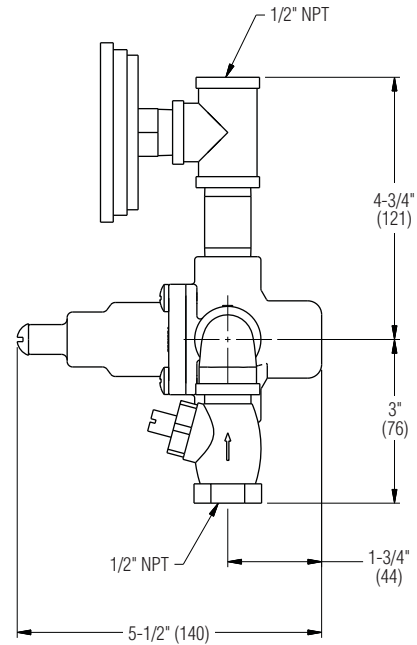

Dimensions — S19-2000 Recessed Cabinet

Front View

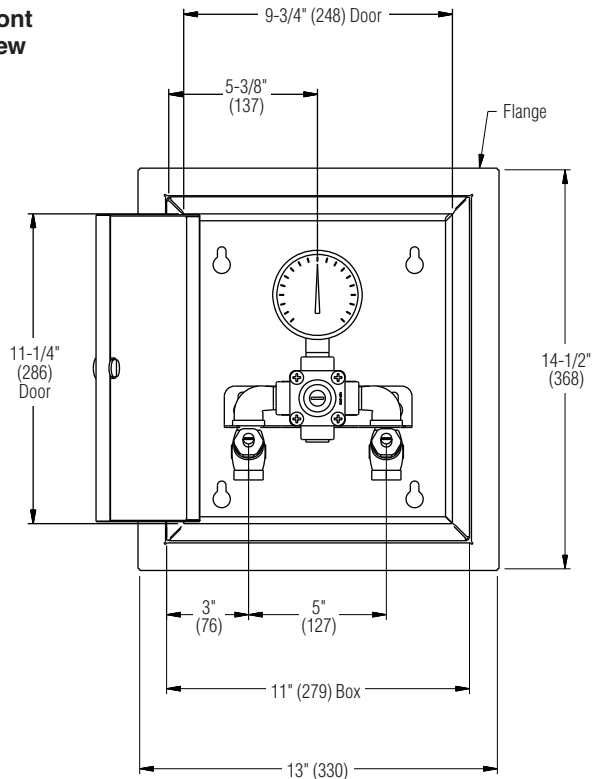

Side View

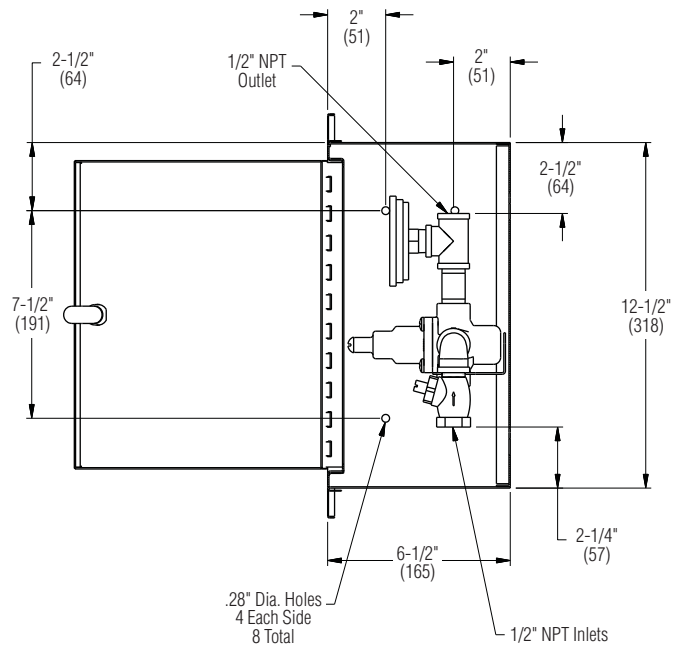

Front View

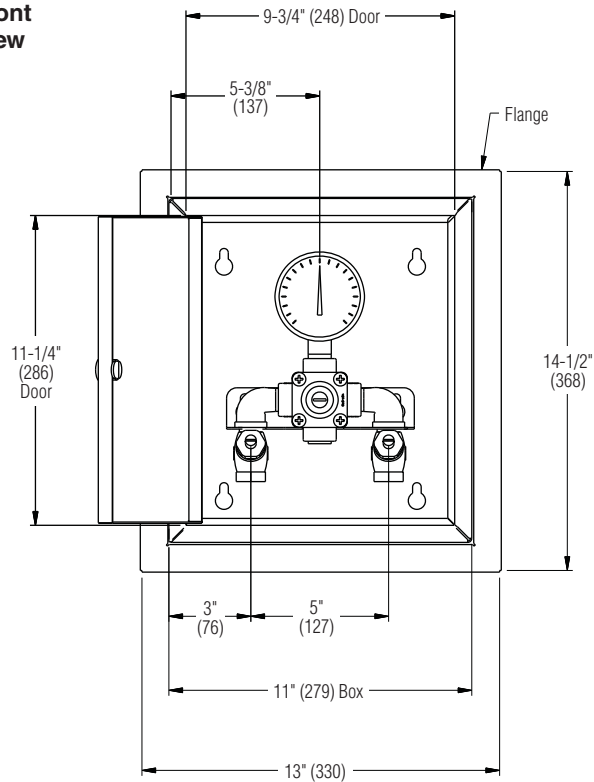

Side View

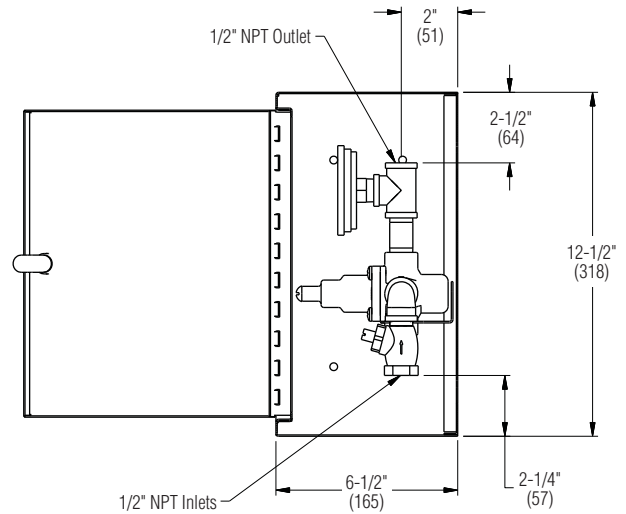

Back View

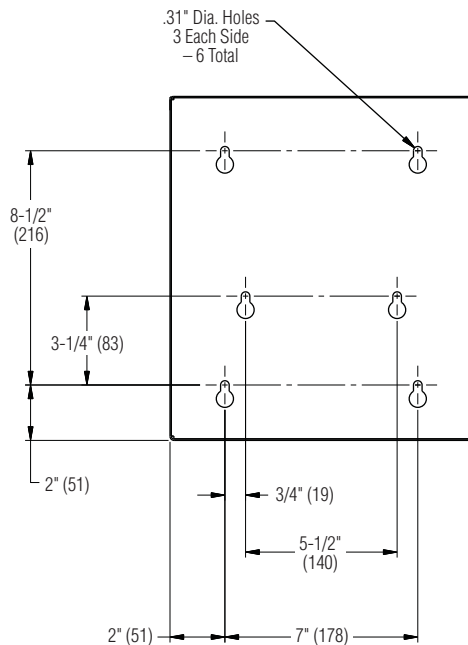

Bottom View

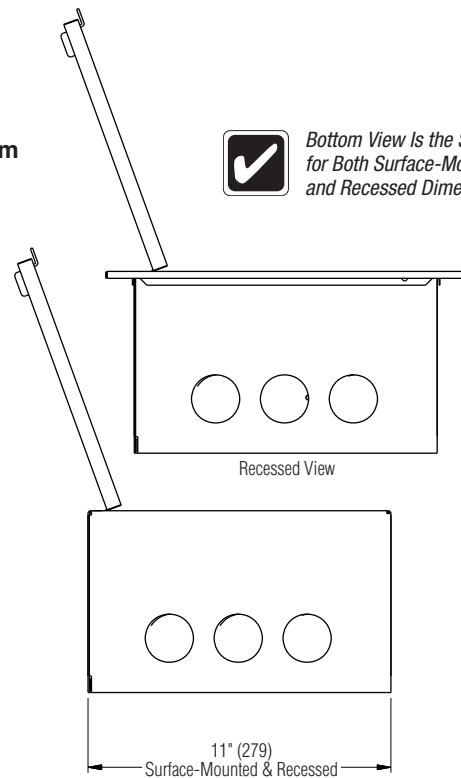

Bottom View Is the Same for Both Surface-Mounted and Recessed Dimensions.