

- ADA Compliant
- 1-1/2" NPT Inlet Connection
- All units factory tested for proper operation

Specifications

Materials

All cabinet materials, including interior piping are Type 304 stainless steel. The fixture is made from heavy gauge stainless steel with seamless welded surfaces.

Construction

All welded construction with exposed welds ground smooth, and all accessible seams and voids eliminated. Fixture will withstand up to 5,000 lb. load on front area of toilet (certified test results of such loading are available upon request). Waste outlet is a no-hub connection. Elongated die-drawn bowl has siphon jet action for positive flush. 30 PSI (flowing into flush valve) required for flushing. A 1.6 gallon-per-flush (low-flow) toilet is standard. Toilet assembly meets ANSI/ASME A112.19.2.



When choosing the Floodbuster option, a minimum of 35 PSI flowing into the Floodbuster valve is required.

Flush Valve

Flush valve is not included as standard equipment with the unit. Flush valve included when specified.

Finish

All exposed steel surfaces to have a bead blast finish (optional #4 satin polished finish, integral contoured seat polished to option #7 sanitary finish). Hinged plastic seat is white.

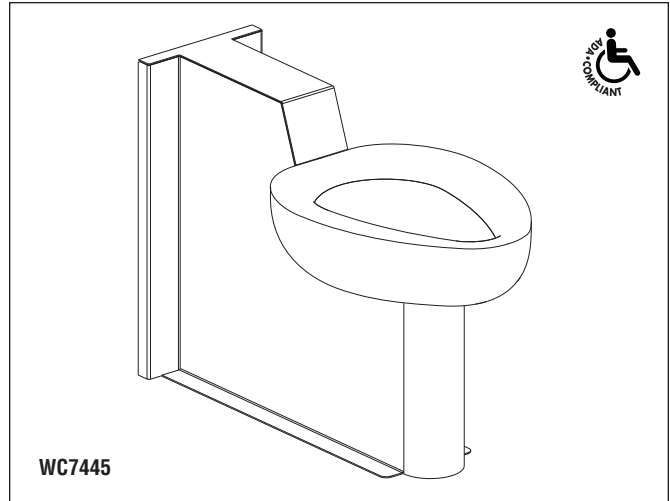

Wall Anchoring

No exposed mounting fasteners in cell area – fixture is completely secured from pipe chase side, with rust-resistant mounting hardware for walls up to 12" thick.



Fixture requires wall openings and accessible chase for installation and maintenance. Some field assembly may be required.

Model	Description
<input type="checkbox"/> WC7445	Chase-Mounted Siphon Jet Stainless Steel Toilet
Required Selections (Must select one from each category)	
Supply (select one):	
<input type="checkbox"/> BACK	Back Supply
<input type="checkbox"/> TOP	Top Supply
Toilet Seat (select one):	
<input type="checkbox"/> ISEAT	Integral Seat
<input type="checkbox"/> PSEAT	Plastic Seat (White)
Finish (select one):	
<input type="checkbox"/> BB	Bead Blast (Standard)
<input type="checkbox"/> PS	Polished Stainless Steel
Wall Thickness (select one):	
<input type="checkbox"/> 0-4	0-4" Wall Thickness
<input type="checkbox"/> 4-8	4-8" Wall Thickness
<input type="checkbox"/> 8-12	8-12" Wall Thickness
In Chase Flush Valve (select one):	
<input type="checkbox"/> LCCPFV	Low Consumption Chrome Plated Mechanical Flush Valve
<input type="checkbox"/> LCMFV	Low Consumption Mechanical Flush Valve
<input type="checkbox"/> LCHFV	Low Consumption Hydraulic Flush Valve
<input type="checkbox"/> LCTTFV*	Low Consumption Touchtime® Electronic Flush Valve
<input type="checkbox"/> NFV	No Flush Valve

Optional Selections

Thru Wall Flush Valve Inlet Connections:

- MMC Male to Male Connection MFC Male to Female Connection

Water Closet Waste Outlet Accessories:

- 3NH 3" No-Hub Coupling
 4NH 4" No-Hub Coupling
 4COT 4" No-Hub Clean-Out Tee
 4COTH 4" No-Hub Clean-Out Tee with Clean-Out Hook
 4COTH 4" No-Hub Clean-Out Tee with Clean-Out Pin
 4COH 4" Clean-Out Hook
 4COP 4" Clean-Out Pin

Floodbuster (must be located in chase):

- FBM Mechanical Floodbuster

TOP VIEW

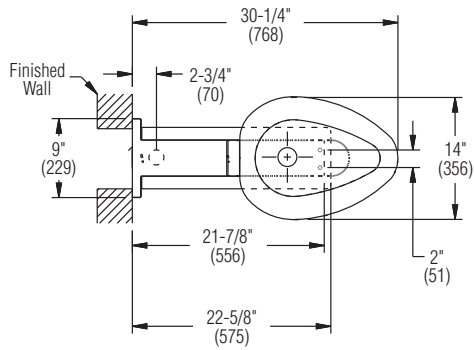

SIDE VIEW

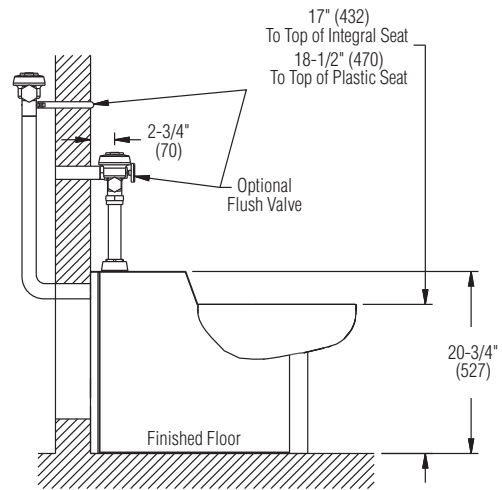

ROUGH-IN VIEW

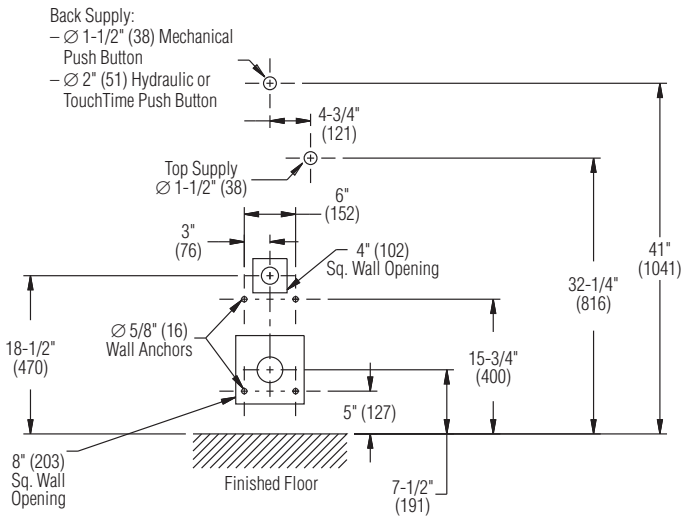

SLEEVE

