

Mirror with angle frame, welded corners and theft-resistant mounting:

- Standard Model 780-1830 (18" x 30") **Bradex**[®]
- Standard Model 780-1836 (18" x 36") **Bradex**[®]
- Standard Model 780-2436 (24" x 36") **Bradex**[®]
- Standard Model 780-2460 (24" x 60") **Bradex**[®]
- Model 780-XXXX (Specify width and height)

Product Materials

FRAME: one-piece roll-formed stainless steel, 3/4" x 3/4" angle with corners welded, ground and polished smooth to a satin finish. Double strength continuous integral stiffener on all sides for added strength. Bevel on front of angle secures frame flush against mirror.

BACK: galvanized steel, secured to frame with concealed screws, equipped with integral horizontal hanging brackets.

MIRROR: first quality 1/4" float glass, triple plated with electro-copper-plated layer and thermosetting infrared cured-paint backing with Poly-Glaze protective finish. Manufactured in accordance with ASTM C 1036. All edges protected by shock-absorbing, neoprene tubing. The back of the mirror is protected by a sheet of 1/4" extruded polystyrene, which is placed between the mirror and the galvanized steel.

WALL HANGER: 18 gauge cold rolled steel, all welded construction to form rigid template.

Optional Features

Features	Suffix
<input type="checkbox"/> 1/4" tempered glass mirror in lieu of polished float glass mirror*	-2
<input type="checkbox"/> Laminate glass	-3
<input type="checkbox"/> Highly polished No. 8 architectural finish, 20 gauge stainless steel in lieu of polished float glass mirror	-4
<input type="checkbox"/> Bright annealed 20 gauge stainless steel in lieu of polished float glass mirror	-5
<input type="checkbox"/> Plexiglas [®]	-6

*Either the Length (L) or the Width (W) must be greater than 25".

- An inherent characteristic of a manufacturing process for tempered glass is distortion which may vary from mirror to mirror.
- Stainless steel mirrors will differ in optic quality from glass mirrors.
- In larger sizes, stainless mirrors are subject to distortion and/or "oil canning" for which Bradley Corporation cannot accept responsibility.
- Bradley mirrors are not field interchangeable from horizontal to vertical or vice versa. **Always specify width first.**

**Washroom Accessories
Document No. 8775**



Installation

Verify all rough-in dimensions prior to installation. Secure concealed mounting bracket to wall with screws (not included) at holes provided. Mounting kits available through Bradley (ref. #899-026). For more information, visit bradleycorp.com. Provide in-wall backing at mounting screw locations. Position mirror over mounting bracket to engage hanger tabs. Slide mirror down and lock into position.

Guide Specification

Mirror shall be framed with heavy gauge, one-piece roll-formed 3/4" x 3/4" stainless steel angle with double strength continuous integral stiffener. Welded corners shall be polished to a uniform satin finish. Mirror shall be of first quality 1/4" float glass guaranteed for 15 years against silver spoilage and protected by a shock-absorbing, neoprene tubing with Poly-Glaze protective finish. Back of unit shall be galvanized steel secure to frame with concealed screws, equipped with integral horizontal hanging brackets and separate wall hanger for concealed mounting.

Framed Mirror shall be Bradley Model 780-_____ " W x _____ " H (specify width and height).

 **ADA Compliant**

- Consult local and national accessibility codes for proper installation guidelines.
- Conformity and compliance to local and national codes is the responsibility of the installer.

Orders composed of products indicated as **Bradex**[®] will be available to ship in three days after receipt of order at the factory. There is no pricing penalty for this service from Bradley.

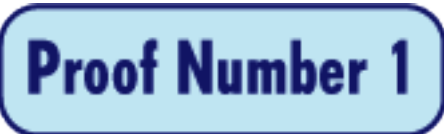

Dimensions

MIRRORS 30" WIDE AND UNDER

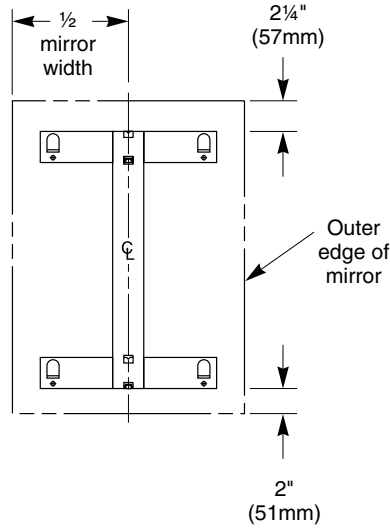

MIRRORS OVER 30" WIDE

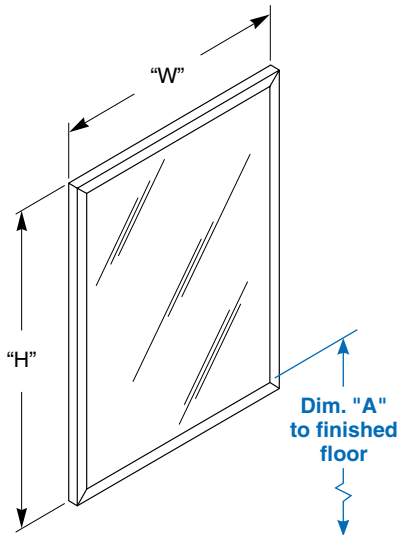
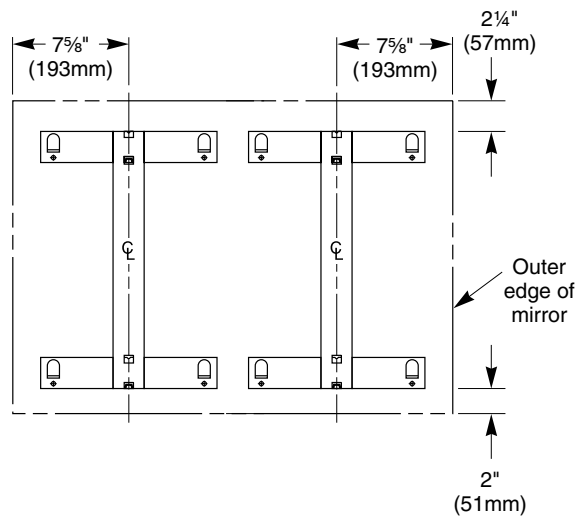

Bradex® Models

Width (Inches) W	Height (Inches) H	Overall Dimension (Inches)	Overall Dimensions (Millimeters)	Standard Model Number
18"	30"	18 x 30	457 x 762	780-1830
18"	36"	18 x 36	457 x 914	780-1836*
24"	36"	24 x 36	610 x 914	780-2436*
24"	60"	24 x 60	610 x 1524	780-2460

Model 780 series angle framed mirrors can be fabricated to a maximum size of 120"W x 72"H.

* Indicates available Tempered glass. **Bradex®**

Dim. "A" Key Surface:	For Dim. "A"	Bottom of Unit
Mirror's bottom edge of the reflecting surface to finished floor	40" (1016mm)	39 1/4" (997mm)
	37" (940mm)	36 1/4" (921mm)
	34" (864mm)	33 1/4" (845mm)
Rough wall opening:		
Surface Mount:	No rough wall opening, see overall dimensions	

**Washroom Accessories
Document No. 8775**

Orders composed of products indicated as **Bradex®** will be available to ship in three days after receipt of order at the factory. There is no pricing penalty for this service from Bradley.