

Installation

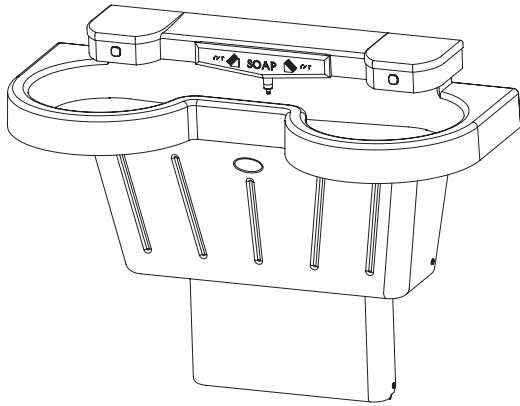

SS-3N/BIR3/STD/LSD-3

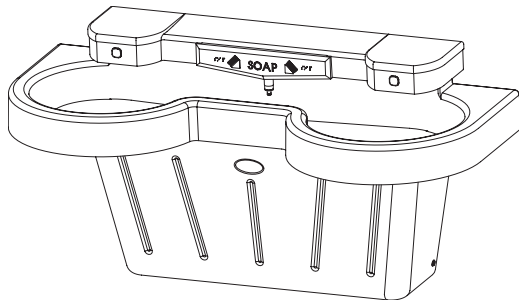

SS-3N/BIR3/WH/LSD-3

SS-2N/BIR3/STD SS-2N/BIR3/WH

Express® Lavatory System SS-Series

Express Lavatory Systems are ADA and TAS compliant

U.S. Pat. Nos. 5,611,093; D447-224

Other Patents Pending

Table of Contents

Pre-Installation Information	2
Components	3
Supplies Required	4
Dimensions - Front and Top Views	4-5
Rough-Ins	6
Mount the Frame	7
Install the Bowl	7
Connect the Supply - Hot and Cold Supply	8
Connect the Supply - Single Tempered Supply	8
Install the Drains	9
Connect Electrical and Sprayhead Supplies	9
Adjust the Temperature	10
Cleaning and Maintenance	11
Troubleshooting – BIR3 Components	12
Solenoid Valve	13
Stop Valve Troubleshooting	13
Thermostatic Mixing Valve Troubleshooting	14
Fill Soap Dispenser	15
Clean Soap Dispenser	15



⚠ WARNING

Make sure that all water supply lines have been flushed and then completely turned off before beginning installation. Debris in supply lines can cause valves to malfunction.

Turn OFF electrical power to the electrical outlets, then unplug all electrical units prior to installation. Electrical power **MUST** remain off until installation is complete. After installation is complete, turn on the water supply first, then turn on the electrical power.

Installer's hardware must be appropriate for wall construction. Wall anchors must have a minimum pull-out rating of 1,000 pounds.

NOTICE

Overtightening fasteners can damage the Terreon material. Use caution when tightening bowl and sprayhead fasteners.

IMPORTANT

Read this entire installation manual to ensure proper installation. When finished with the installation, file this manual with the owner or maintenance department. Compliance and conformity to local codes and ordinances is the responsibility of the installer.

Separate parts from packaging and make sure all parts are accounted for before discarding any packaging material. If any parts are missing, do not begin installation until you obtain the missing parts.

Product warranties may be found under "Products" on our website at www.bradleycorp.com.

Components

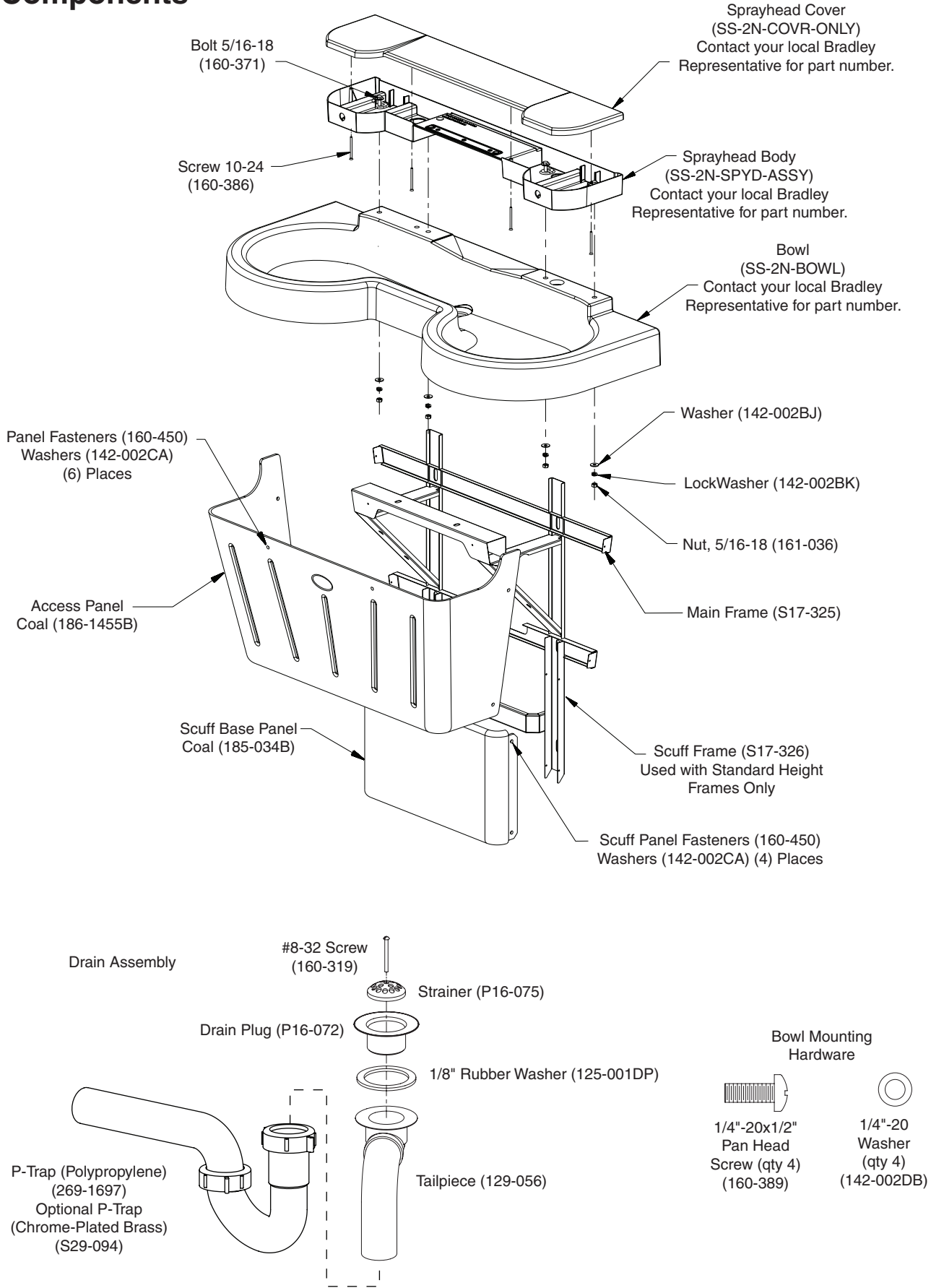

Supplies Required

- (6) 3/8" wall anchors, bolts and 1" min. O.D. washers to mount main frame and bowl to wall (minimum pull-out rating of 1,000 lbs.)
- STD. HEIGHT ONLY: (2) 3/8" wall anchors, bolts and 1" min. O.D. washers to mount scuff base to wall
- 1/2" nominal copper tubing for hot and cold supplies and 1-1/2" NPT drain piping

Dimensions - Front and Top Views

(mm)

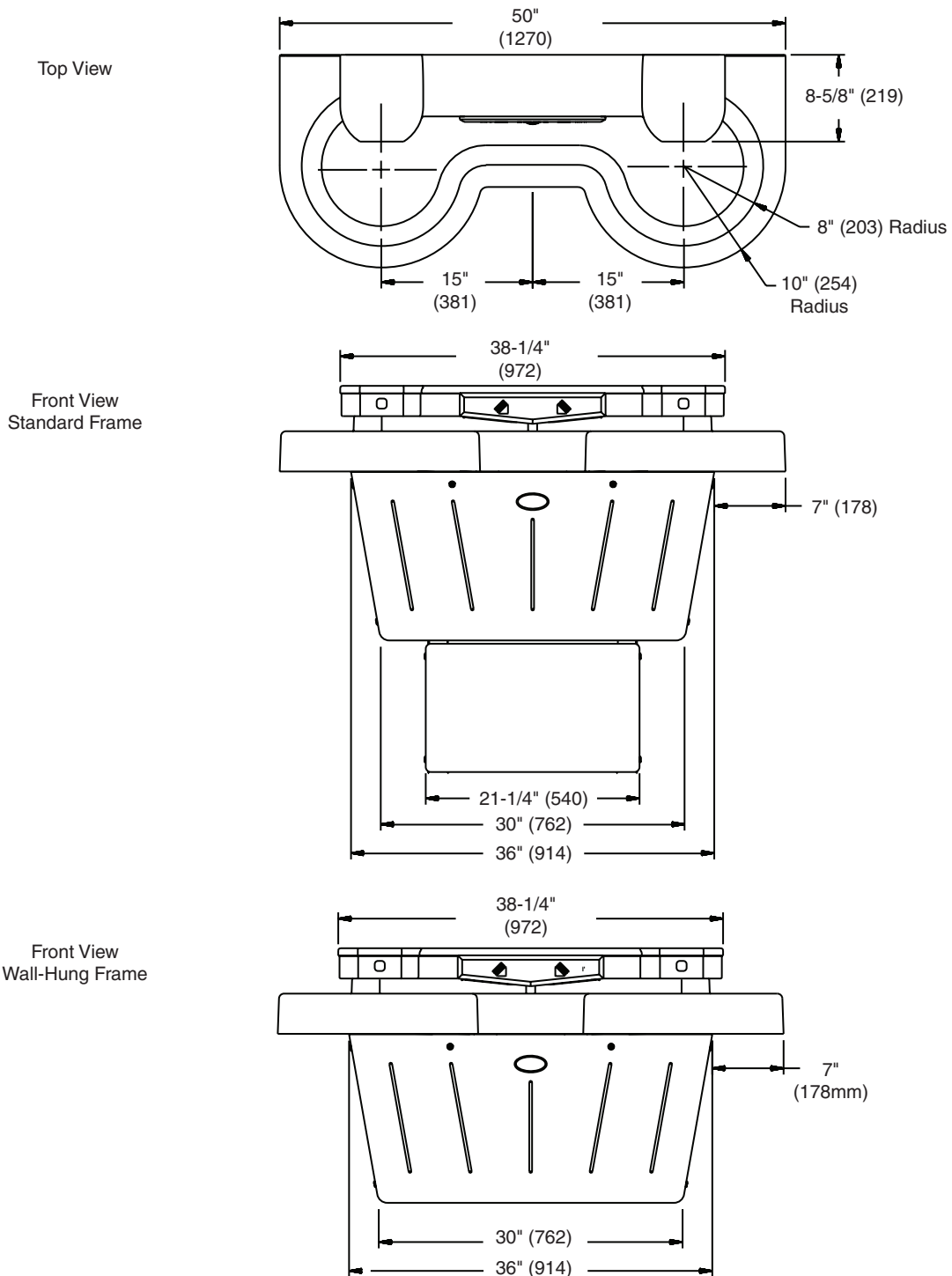

Dimensions - Side Views

Standard Height

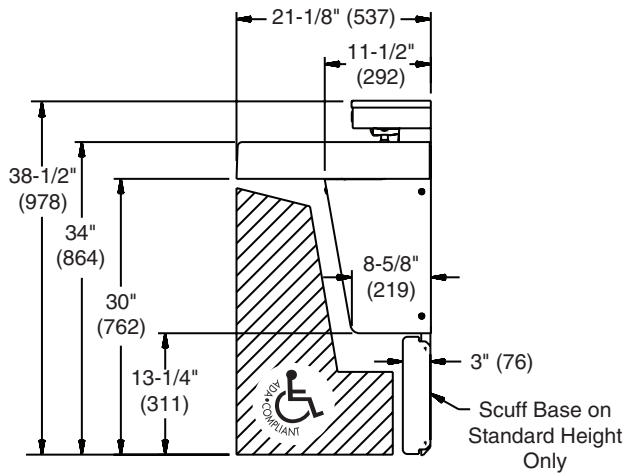

Wall Hung Mounted at Standard Height

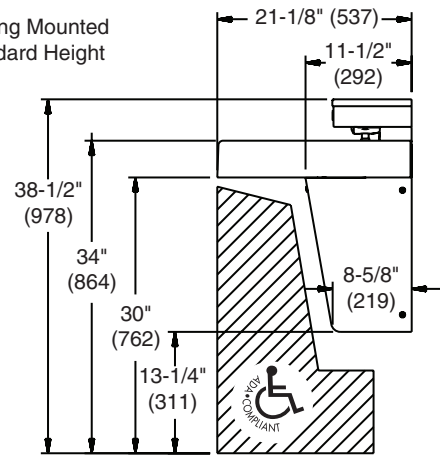

Wall Hung Mounted at Juvenile Height Ages: 6 through 12

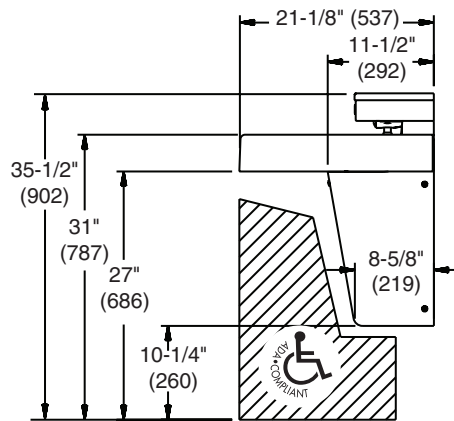

Wall Hung Mounted at TAS Height Grades: 6 through 8 or 9

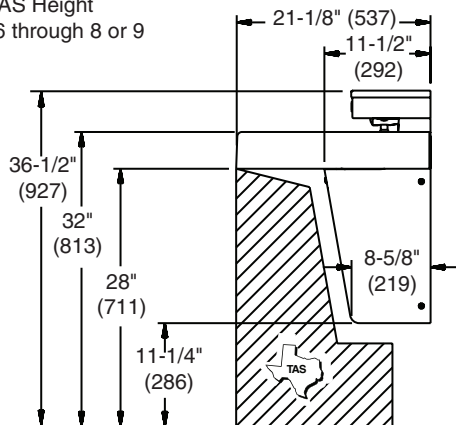

Wall Hung Mounted at TAS Height Grades: Pre-K through 5 or 6

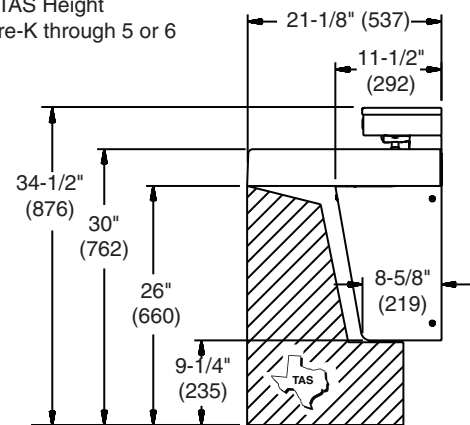

1 Rough-Ins

(mm)

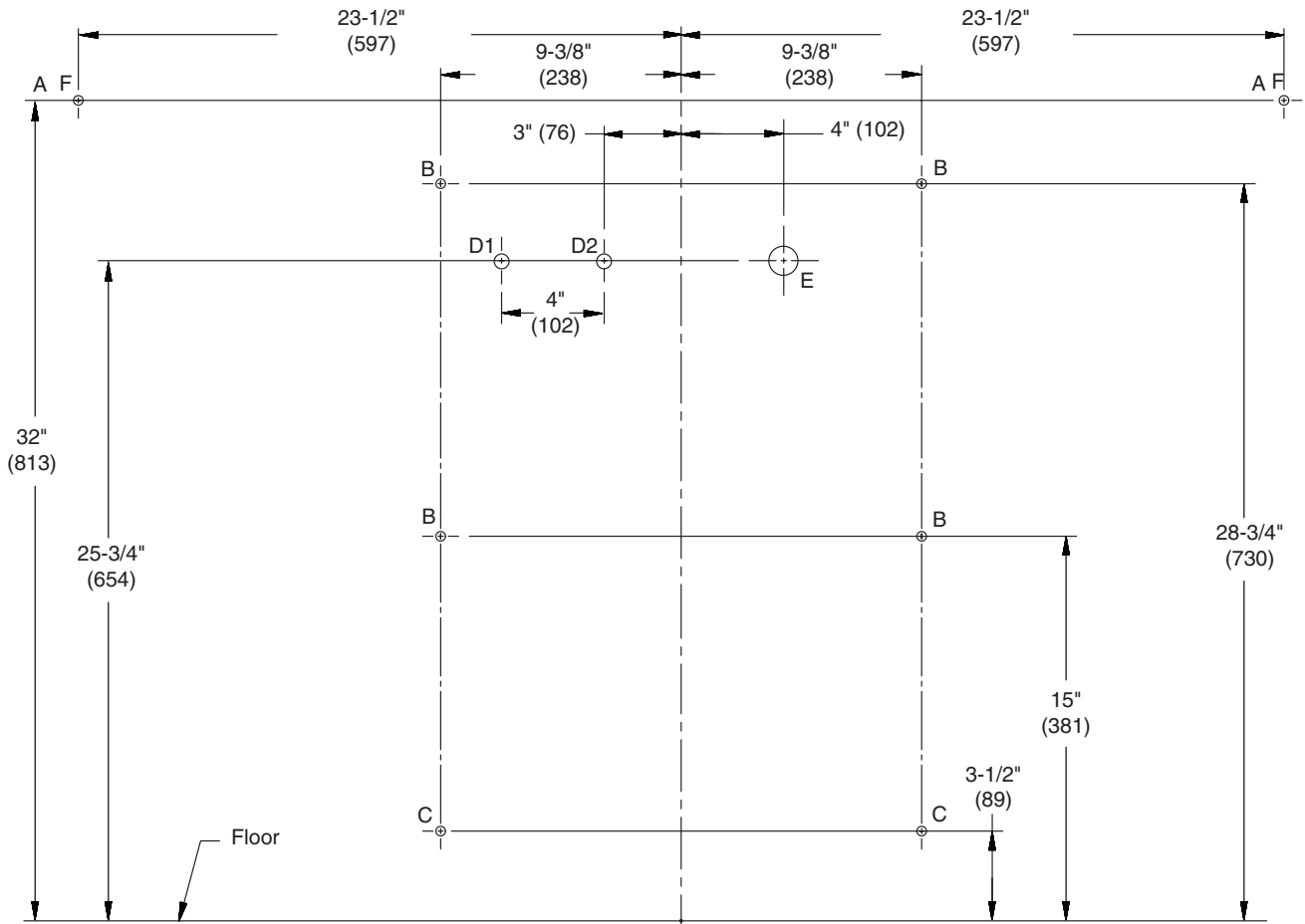

CODE	DESCRIPTION	QTY.
A	3/8" Wall Anchors with a minimum pull-out force of 1,000 lbs. for Bowl	2
B	3/8" Wall Anchors with a minimum pull-out force of 1,000 lbs. for Mainframe	4
C	3/8" Wall Anchors for Base Frame, Standard Frame option only, minimum pull-out force not required	2
D1	1/2" nominal copper tubing for Cold Supply, stub-out 2" from wall	1
D2	1/2" nominal copper tubing for Hot or Tempered Supply, stub-out 2" from wall	1
E	1-1/2" NPT Drain, stub-out 2" from wall	2
F	On the bowl back, measure the distance between the 3/4" bowl mounting holes. Divide this measurement in half. Measure and mark this dimension on the wall to the left and the right of the centerline. Install two 3/8" wall anchors with a minimum pull-out rating of 1,000 lbs (supplied by installer) at locations marked.	2

RIM HEIGHT	VERTICAL HEIGHT ADJUSTMENTS FOR CODES A-E, H, C and W	FIXTURE STYLE
34"	None	Standard Height
34"	None	Wall-Hung
32"	Subtract 2"	TAS, Grades 6 through 8 or 9
31"	Subtract 3"	Juvenile Height
30"	Subtract 4"	TAS, Pre-K through Grades 5 or 6

2 Mount the Frame



Anchoring the frame to a wall that is not flat may cause the frame to bend, making it difficult to reinstall the access panels. If necessary, use shims to compensate for wall distortion.

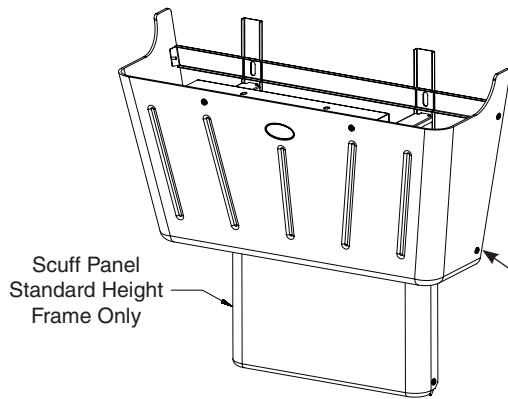

A Using a T20 torx key, remove the fasteners securing the access panel to the main frame, and remove the panel.

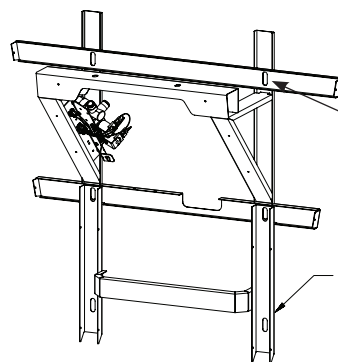

B Once you have positioned the frame such that it is level and flat against the wall or shimmed, mount the frame to the wall at four places using 3/8" bolts and 1" min. O.D. washers.



When mounting the standard height frame, mount the scuff base to the wall at the same time using two additional 3/8" bolts and washers.

3 Install the Bowl



The sprayhead body has slotted holes for adjusting the fit-up with the bowl and wall. The tailpiece on the waste tee has been rotated upward for shipping purposes. Turn the tailpiece down to its proper position before installing the bowl.



A Attach the bowl to the frame using the 1/4-20 x 1/2" pan-head screws and washers. Do not tighten screws.

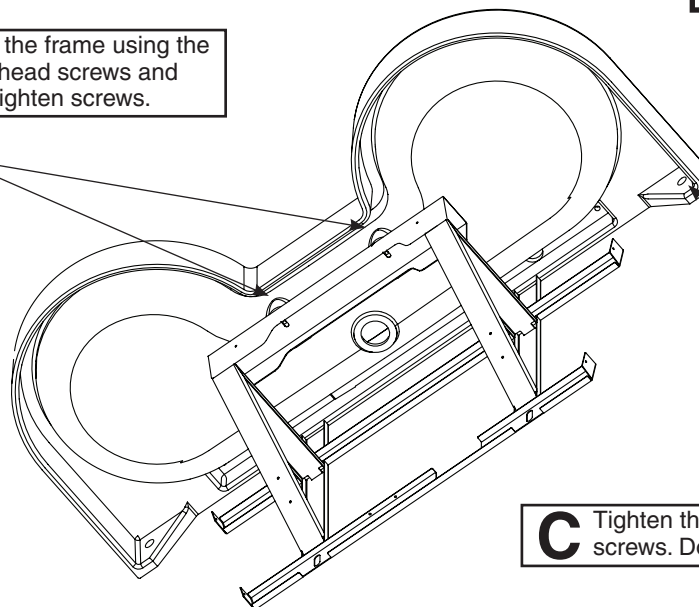

B Secure the bowl to the wall anchors with 3/8" bolts and 1" min. O.D. washers, two places. DO NOT OVERTIGHTEN!

C Tighten the pan-head screws. Do not overtighten.

4a Connect the Supply - Hot and Cold Supply



The letter "H" on the Navigator Mixing Valve indicates hot water supply inlet.

C Connect one end of each hose to the Navigator valve (one on the hot side, one on the cold side).
Connect the other swivel end to the stop valves.

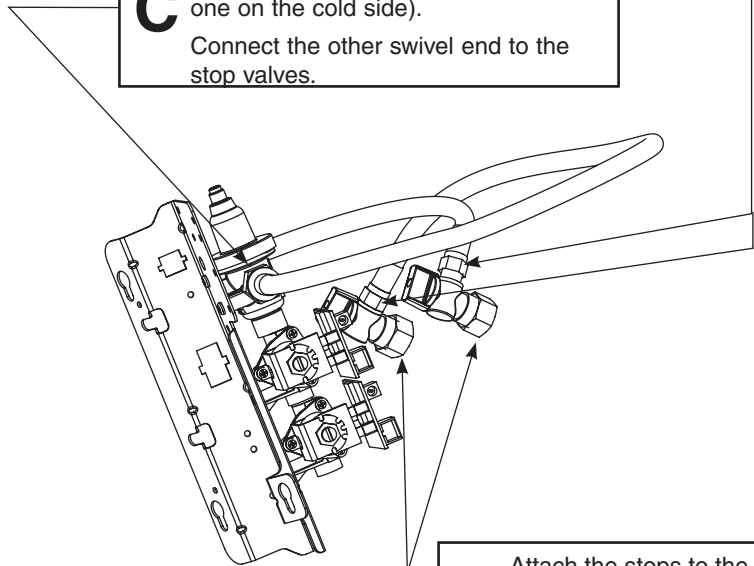

A Loosen but do not remove the two mounting screws holding the valve bracket to the frame.
Slide the valve bracket up and lift it from the frame.

B Attach the stops to the hot and cold water wall stub-outs.

4b Connect the Supply - Single Tempered Supply

C Connect one end of flexible hose to the tempered line adapter.
Connect the other swivel end to the stop valve.

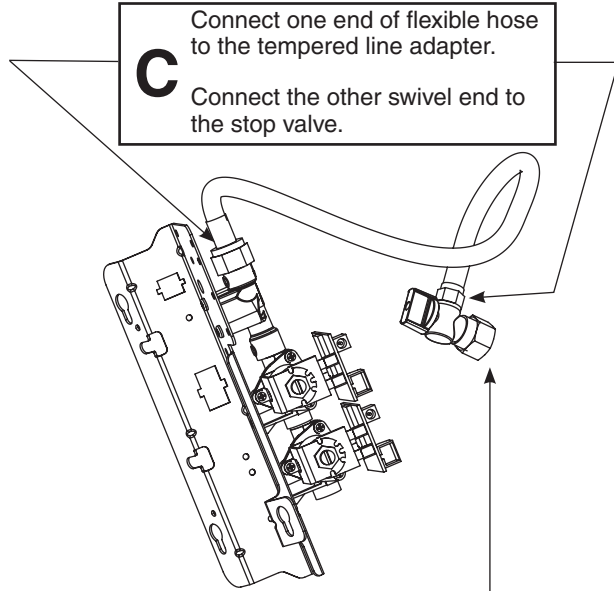

A Loosen but do not remove the two mounting screws holding the valve bracket to the frame.
Slide the valve bracket up and lift it from the frame.

B Attach the stop to the tempered wall stub-out.

5 Install the Drains

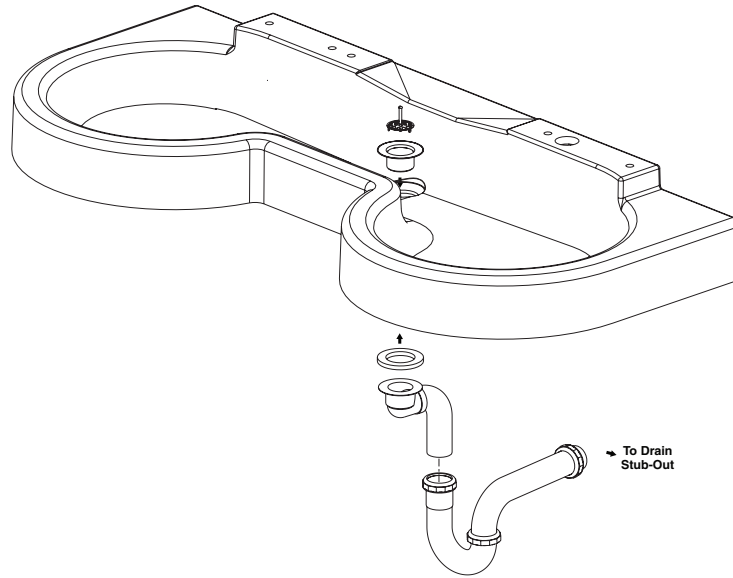

6 Connect Electrical and Sprayhead Supplies

⚠ WARNING! The SS-3N/BIR3 Express must be connected to the 6 VDC battery. Connection to 110 VAC can cause personal injury and will result in damage to the electronics. Connection of leads other than shown may cause permanent damage to the sensor.

NOTICE! To avoid activating the sprayhead valve, make sure to connect the sensor cable plugs to the circuit board before inserting the batteries into the battery holder. If the cable is connected or disconnected while the batteries are installed, the station will activate and continue running for 75 seconds.

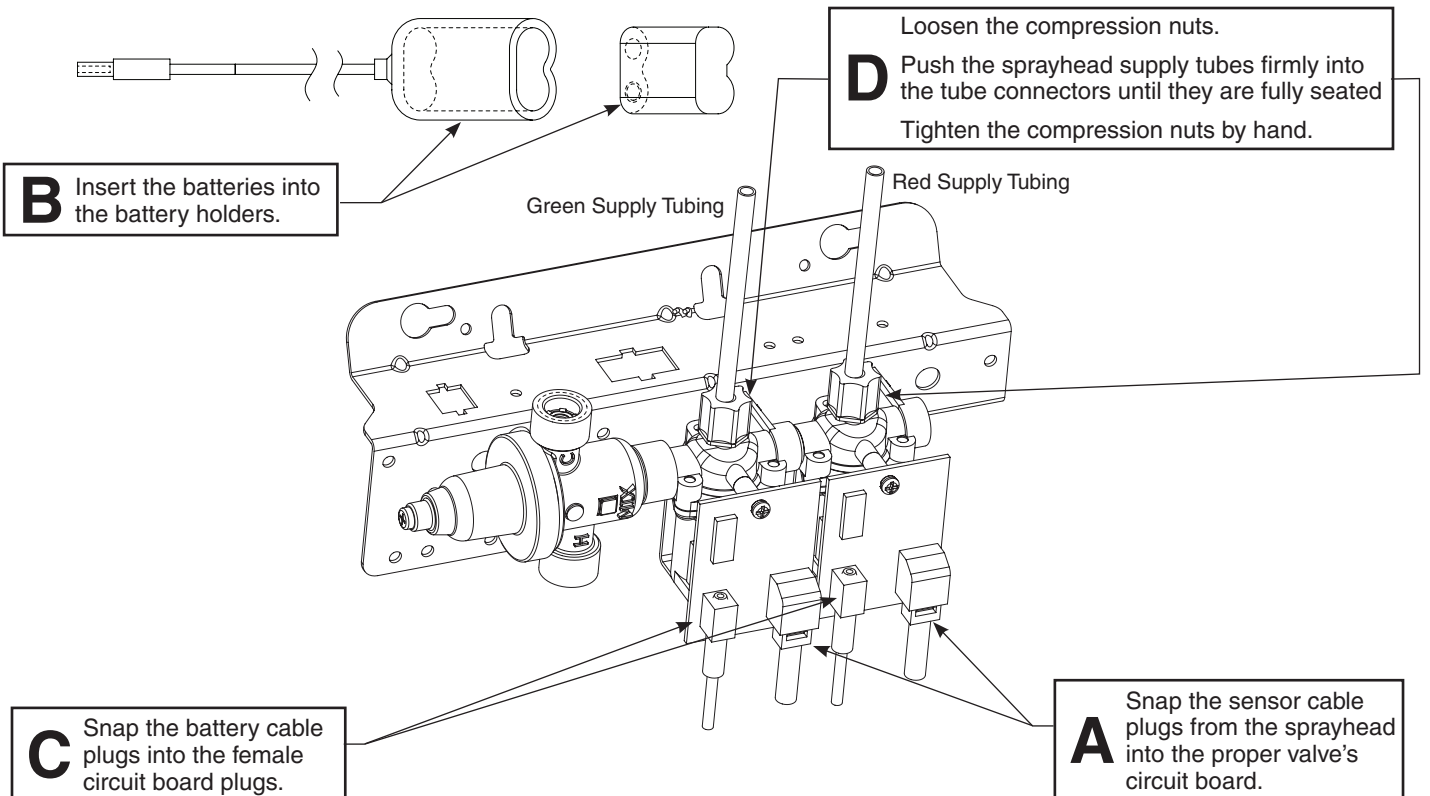

7 Adjust the Temperature



This valve is **NOT** factory preset. Upon installation, the temperature of this valve must be checked and adjusted to ensure delivery of a safe water temperature. Water in excess of 110°F (43°C) may cause scalding.

A Loosen the cap screw about 1/4" (4–6 turns) and lift up the cover (do not remove).

B Using the cover, turn the cartridge gently until desired water temperature is reached. Do not turn past stops as this may damage the unit. Push the cover down and tighten the screw.

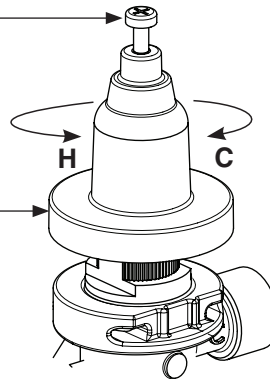

C Reinstall the valve bracket. Turn on the water supply to the Express and check for leaks. Push the operating buttons of each station until all the air is purged from the lines and water is flowing smoothly. Reinstall the access panel.

Cleaning and Maintenance for Terreon®

Material Description: Terreon is a densified solid surface material composed of bio based resin and is resistant to chemicals, stains, burns and impact. Surface can be easily repaired with everyday cleansers or fine grit abrasives. Because Terreon is a unique cast material, its aggregate flow and distribution, and shades of color can vary from product to product creating natural characteristics.

Routine Cleaning: For regular cleaning, use mild neutral base cleaners.

Stubborn Stains: Remove tough stains with Soft-Scrub® and a green Scotch-Brite® pad or lightly sand in a circular motion with 240 grit wet/dry sandpaper. The finish can then be renewed with a maroon Scotch-Brite pad.

Scratches: Remove scratches with a green Scotch-Brite pad. The finish can then be renewed with a maroon Scotch-Brite pad.

Hard Water Deposits: Remove hard water deposits with a mild solution of vinegar and water. Always rinse the unit thoroughly after cleaning.

Restoring the surface: Use Hope's® Perfect Countertop to refresh and protect the Terreon Solid Surface material. Dark Terreon colors may require additional care and maintenance. For complete instructions on this additional maintenance, visit bradleycorp.com.

Repair Kits: Terreon repair kits are available. Contact your Bradley representative or distributor for part numbers and pricing. Repair kits are made to order and have a shelf life of 30 days.

NOTICE! Do not use strong acid or alkaline chemicals and cleaners to clean Terreon. If these chemicals come in contact with the surface, wipe them off immediately and rinse with soapy water. Avoid contact with harsh chemicals such as paint remover, bleach, acetone, etc. Avoid contact with hot pans and objects.

Cleaning and Maintenance for Stainless Steel

Material Description: Stainless steel is extremely durable, and maintenance is simple and inexpensive. Proper care, particularly under corrosive conditions, is essential. Always start with the simplest solution and work your way toward the more complicated.

Routine cleaning: Daily or as often as needed use a solution of warm water and soap, detergent, or ammonia. Apply the cleaning solution per the manufacturer's instructions and always use a soft cloth or sponge to avoid damaging the finish.

Stubborn Stains: To remove stains from stainless steel use a stainless steel cleaner and polish such as Ball® stainless steel cleaner or a soft abrasive. Always follow the manufacturer's instructions and apply in the same direction as the polish lines.

NOTICE! Never use ordinary steel wool or steel brushes on stainless steel. Always use stainless steel wool or stainless steel brushes.

Fingerprints and Smears: To remove fingerprints or smears use a high quality stainless steel cleaner and polish in accordance with the manufacturer's instructions. Many of these products leave a protective coating that helps prevent future smears and fingerprints.

Grease and Oil: To remove grease and oil use a quality commercial detergent or caustic cleaner. Apply in accordance to the manufacturer's instructions and in the direction of the polish lines.

Precautions: Avoid prolonged contact with chlorides (bleaches, salts), bromides (sanitizing agents), thiocyanates (pesticides, photography chemicals, and some foods), and iodides on stainless steel equipment, especially if acid conditions exist.

NOTICE! Do not permit salty solutions to evaporate and dry on stainless steel.

The appearance of rust streaks on stainless steel leads to the belief that the stainless steel is rusting. Look for the actual source of the rust in some iron or steel particles which may be touching, but not actually a part of the stainless steel structure.

NOTICE! Strongly acidic or caustic cleaners may attack the steel causing a reddish film to appear. The use of these cleaners should be avoided.

Brand Names

Use of brand names is intended only to indicate a type of cleaner. This does not constitute an endorsement, nor does the omission of any brand name cleaner imply inadequacy. Many products named are regional in distribution, and can be found in local supermarkets, department and hardware stores, or through your cleaning service. It is emphasized that all products should be used in strict accordance with package instructions.

Troubleshooting – BIR3 Components

⚠ WARNING Turn off water supplies to the unit before troubleshooting.

Problem	Cause	Solution
An individual operating station fails to shut off and drips.	Debris is trapped between the diaphragm and the valve seat.	<p>Remove debris between diaphragm and the valve seat.</p> <ol style="list-style-type: none"> 1. Disconnect the plug from the battery to the circuit board of the problem valve. 2. Remove the three #8 Phillips-head screws that hold the solenoid valve assembly together. Be careful not to lose the armature or spring. 3. Remove the diaphragm. Remove any particles that have been trapped between the diaphragm and the valve seat. Rinse off the diaphragm and inspect for damage. Make sure the center orifice and both small side orifices are open. 4. Reassemble in reverse order (do not overtighten the Phillips-head screws or the plastic valve body may crack). Tighten until the armature plate makes contact with the plastic body. 5. Reconnect the battery plug. Turn on water supplies to the unit.
An individual operating station fails to turn on or off.	A dead or faulty battery.	<p>Test the station to determine the cause and replace battery if required.</p> <ol style="list-style-type: none"> 1. Disconnect the sensor cable from the circuit board of the problem valve. Disconnect the sensor cable from the circuit board of an adjacent working valve. 2. Connect the battery plug from the adjacent working valve to the problem valve. Wait for ten seconds. Activate the problem station's sensor ten times. The station should turn on. <p>If the adjacent station turns on, and cycles normally, replace the battery.</p>
	Faulty sensor eyes.	<p>Test the station to determine the cause and replace sensor eyes if required.</p> <ol style="list-style-type: none"> 1. Disconnect the plug from the battery to the circuit board of the problem valve. Disconnect the plug from the battery to the circuit board of an adjacent valve. 2. Connect the sensor cable from the adjacent working valve to the problem valve. Activate the problem station's sensor. The station should turn on. <p>If the adjacent station turns on, and cycles normally, replace the sensor eyes.</p>
	Faulty solenoid valve.	<p>Test the station to determine the cause and replace solenoid valve if required.</p> <ol style="list-style-type: none"> 1. Remove the screw, circuit board and standoff from the problem valve. Remove the battery holder. 2. With a good working battery, briefly contact the solenoid valve directly with the battery. The contact should cause the valve to open. With the battery holder removed, briefly contact the solenoid valve with the battery in the position shown. This should cause the valve to close. If the valve does not operate when directly contacted with a good battery, and the solenoid valve has already been cleaned as outlined at the beginning of this troubleshooting section, replace the solenoid valve. <p>If problems persist: Pass your hand in front of the problem station, while at the same time looking to see if the indicator light on the circuit board flashes (the indicator light is located near the hole in the circuit board where the standoff is mounted). If it does not flash, and the battery and sensor eyes have already been tested as outlined above, the problem may be with the circuit board. Make a note of the numbers printed on the circuit board, then contact your Bradley representative for assistance.</p>

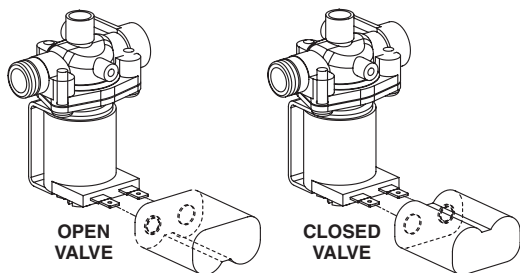

Solenoid Valve: Part nos. S07-072 (closed body) & S07-072A (thru body)

⚠ WARNING Turn off water supplies to the unit before troubleshooting.

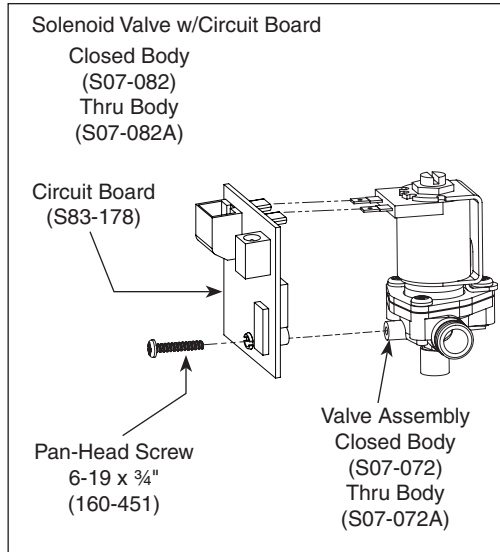
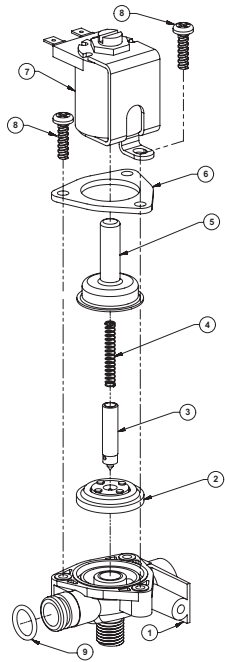

Item	Qty.	Part No.	Description
1	1	118-307	Valve Body, 1/4" Closed
1	1	118-307A	Valve Body, 1/4" Thru
2	1	269-983	Diaphragm
3	1	192-017	Armature
4	1	135-093	Spring
5	1	269-1729	Armature Housing
6	1	269-1730	Clamp, Armature Housing
7	1	269-1731	Coil, Solenoid Valve
8	3	160-447	Screw, #8 x 5/8"
9	1	125-165	O-Ring, #2-013

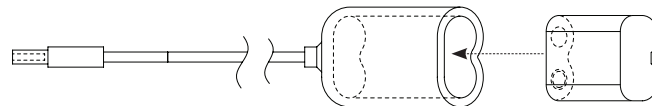

Battery Holder (S83-177)

6-volt Lithium Battery (261-010)

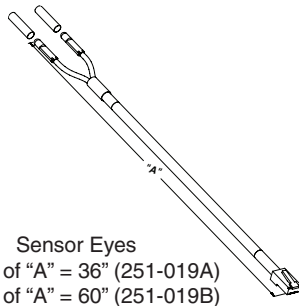

Sensor Assembly Components

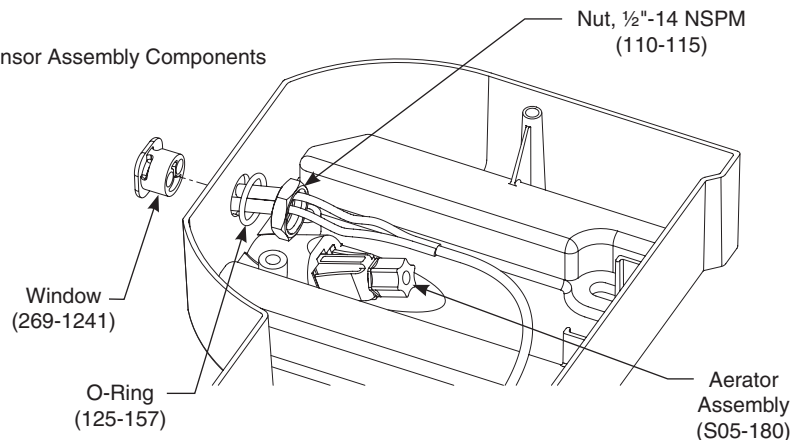

Stop Valve Troubleshooting

Problem	Cause	Solution
Water dribbles or does not flow from the sprayhead.	Stop Valves may not be functioning properly.	<ol style="list-style-type: none"> 1. Close the stops and inspect the valves that supply water to the lavatory system. 2. Inspect the stop valves to see that they have been properly installed.
Sprayhead delivers ONLY hot OR cold water.	Stop Valves may not be functioning properly.	<ol style="list-style-type: none"> 1. Close the stops and inspect the valves that supply water to the lavatory system. 2. Inspect the stop valves to see that they have been properly installed. 3. Inspect the thermostatic mixing valve for proper installation and connection to hot and cold supplies.

Thermostatic Mixing Valve Troubleshooting

Before attempting to troubleshoot the valve or disassemble the components, check for the following conditions:

- If stop valves are used, make sure that they are fully open.
- Make sure that the hot and cold inlet pipes are connected properly, and that there are no cross-connections or leaking stop valves.
- Check the hot water heater output to make sure that it is at least 10° F above the set temperature.



Be sure to close the appropriate shut-off valves prior to disassembly of the valve and reopen the valves after inspection and repair is complete.

Problem	Cause	Solution
External leaks.	Damaged cartridge or O-rings.	Replace cartridge with part number 269-1927
Improper water temperature or temperature fluctuation.	Hot water supply is not 10° above desired set point.	Increase hot water supply temperature
	Valve temperature is not properly set.	Adjust the temperature as shown on page 10, step 7.
Limited water flow.	Dirt and debris have built up in the valve or strainer.	<ol style="list-style-type: none"> 1. Check to make sure both hot and cold supplies are connected to the Navigator mixing valve and that they have water flow. 2. Remove cover and U-clip. Remove the cartridge and clean the strainer. It is not required to grease cartridge, however if desired, use silicone grease only. Do not use grease on check valves.

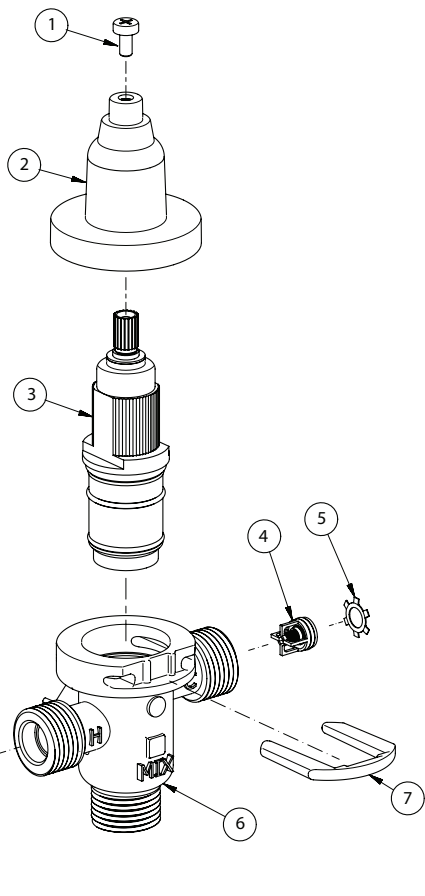

Parts List

Item	Part No.	Description	Quantity
			S59-4000
1	160-463	Cap Screw	1
2	107-582	Cover	1
3	269-1927	Thermostatic Cartridge	1
4	198-014	Check Valve*	2
5	132-051	Retaining Ring*	2
6	118-319	Valve Body	1
7	146-079	U-Clip	1

* Included with Prepack S65-326

Tempered Line Adapter Option
Part no. S39-804
 (replaces S59-4000 if tempered line is used)

Strainer (173-028)

Fill Soap Dispenser



The soap valve will dispense vegetable/coconut oil liquid soaps, synthetic detergents, viscous lotion soaps, and antiseptic solutions. A 10-15% concentration is recommended for vegetable or coconut oil liquid soaps. Before filling, rinse out each soap tank with hot water to remove packing dust. Shake water out thoroughly and allow to dry. Do not over fill!

Soap tank kit S65-291B (coal) includes:

- Coal Tank w/ Valve (S11-220B)
- Leaf Spring (S39-350)
- Screw (160-385)

Soap Valve Repair Kit (S65-258) includes:

- Nut
- Spring
- Washer
- Plunger

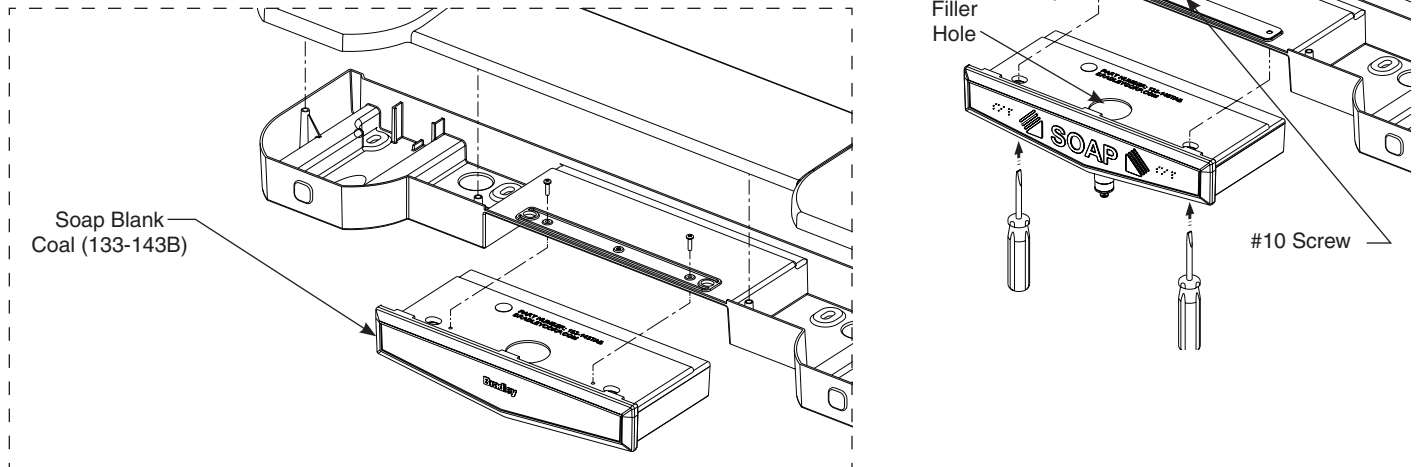

Clean Soap Dispenser

NOTICE! Do not use abrasive cleansers to clean the soap tank. Abrasive cleaners can damage the surface.

Regular cleaning of the soap dispenser is recommended to ensure optimum performance and maximum service life. Cleaning the soap dispenser monthly to remove soap residue, dirt, and other accumulations should become a regular part of your washroom cleaning routine and general maintenance program.

Clean exterior: Use warm water and soap to clean the exterior of the soap dispenser. Dry with a soft cloth.

Clean interior: Inspect the interior of the tank for residue or coagulation of soap. If necessary, clean the tank according to the following procedure:

1. Pour out any remaining soap in the tank.
2. Full the tank half-full of hot water and shake the tank to dislodge the soap residue.
3. Empty the water from the container and repeat steps 1 and 2 until the soap container is clean.

If rinsing alone does not remove the soap residue, place a small chain (24 inches long) into the tank with hot water and shake the container until the chain dislodges the residue. Then remove the chain and rinse out the tank.

Clean internal components: Pump hot water through the soap dispenser until a clean flow of water comes out of the valve.

To change soap, pour out all of the soap from the dispenser and rinse with hot water several times until all residue is removed. Pump the valve until clean water appears. Rinse the dispenser with ethyl alcohol; air dry before refilling.