

Parts & Service

Discontinued Models
Prior to February 1, 2013
Call for Parts Availability

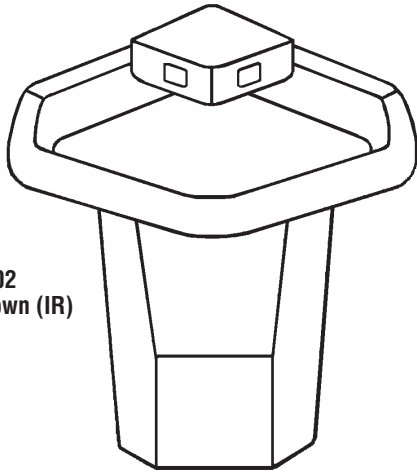

MF2902
Infrared Shown (IR)

MF2902

Terrazzo Corner-Fount
Washfountain

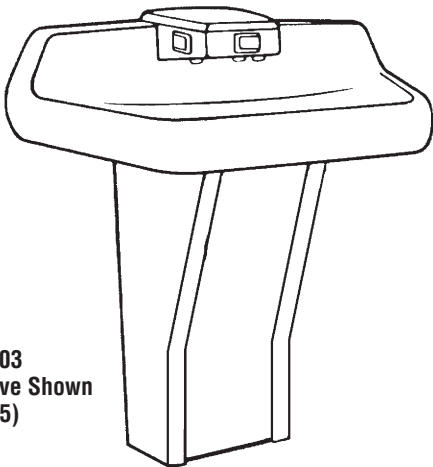

MF2903
Metering Valve Shown
(90-75)

MF2903

Terrazzo Tri-Fount
Washfountain

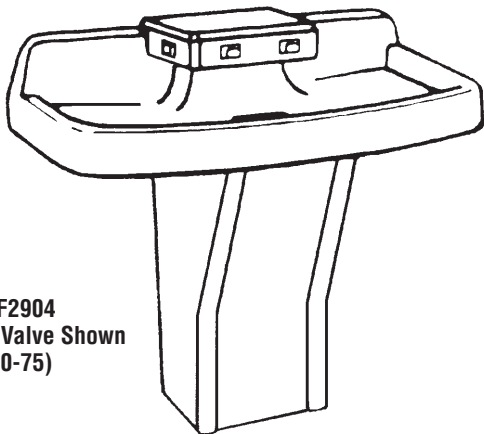

MF2904
Metering Valve Shown
(90-75)

MF2904

Terrazzo Quadra-Fount
Washfountain

Table of Contents

Infrared (IR) Sprayhead and Streamformer	2
Infrared (IR) Solenoid Valve	4
Infrared (IR) Sensor and Valve Troubleshooting.....	7
90-75 Sprayhead and Streamformer.....	8
90-75 Metering Valve	10
90-75 Cartridge.....	13
Supply and Mixing Valve	14
Vernatherm® Thermostatic Mixing	
Valve S01-116B.....	17
Soap System.....	18
Pedestal Assembly.....	22
Pedestal Panels	23
Drain Spud and Strainer	24
Maintenance Instructions	24



Part numbers are subject to
change without notice.

Infrared (IR) Sprayhead and Streamformer Parts and Replacement

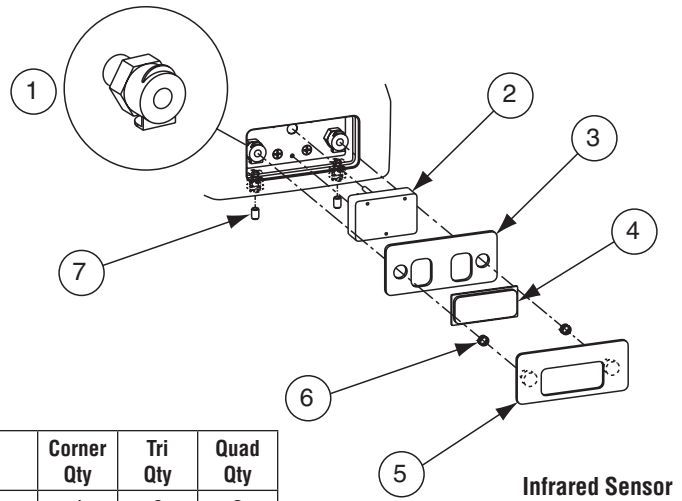

Infrared Sensor and Sprayhead Assembly Parts List

Item	Part No.	Description	Corner Qty	Tri Qty	Quad Qty
1	269-382	Coupling Nut - Quick Disconnect	4	6	8
2	S65-107	Multi-Fount Sensor Repair Kit (269-1184 without connectors)	-	-	-
3	124-070	Gasket, MF Window Terrazzo	2	6	8
4	269-604	Window, IR MF Terrazzo	2	3	4
5	S53-127	Window Plate, IR MF Terrazzo	2	3	4
6	135-049	Spring, Window Plate	2	6	8
7	160-246	Screw 1/4-20 x 3/8, Set SC 18-8 SS	2	6	8
*	269-621	Female Connector (3 required per 269-1184)	6	9	12

* Not Illustrated

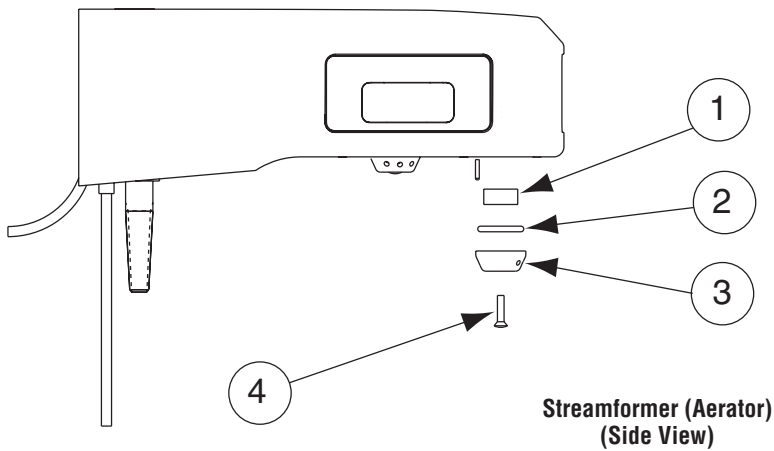

Streamformer Assembly Parts List

Item	Part No.	Description	Corner Qty	Tri Qty	Quad Qty
1	269-508	Sprayhead Diffuser MF	4	6	8
2	125-001EG	O-Ring	-	-	-
3	115-125	Streamformer	2	6	8
4	160-289	Screw 8-32 x 3/4, Oval Head	2	6	8

Infrared (IR) Sprayhead and Streamformer Parts and Replacement (continued)

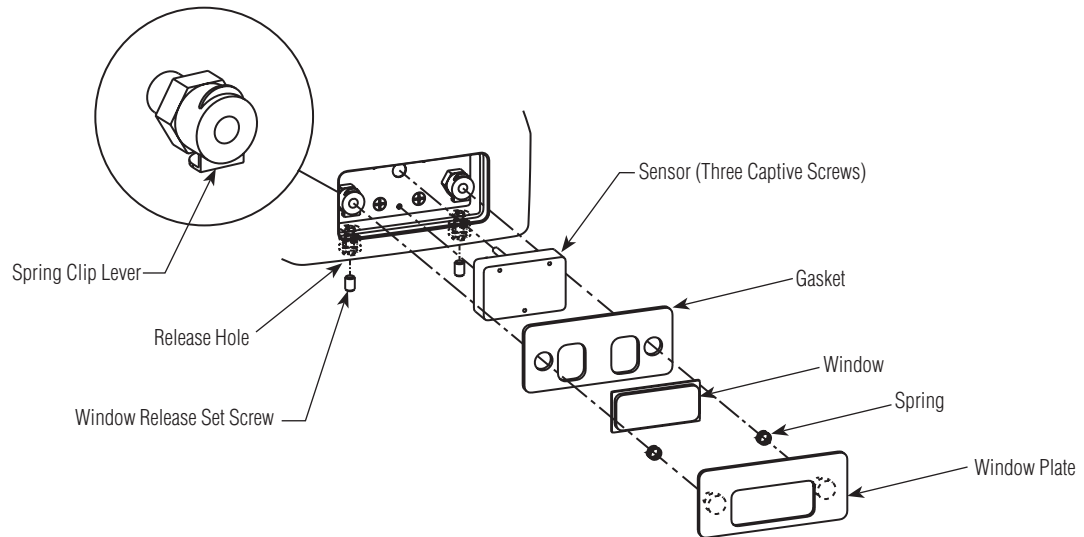

1 Change the Sensor or Window

A Use an 1/8" allen wrench to remove the window release set screws (item 7), located under the sprayhead. This allows access to the release holes under the sensor.

B The "Spring Clip Lever" gets pushed in to release the sensor assembly from the sprayhead. Push the allen wrench up into release holes to push on the spring clip lever on the quick disconnect coupling nut (item 1). This lever will click and lock in the open position to allow removal of the window and sensor.

C Remove the sensor window plate, window and gasket.

D Loosen the three screws holding the sensor in place.

E Cut the insulated terminals off the sensor cable and remove the sensor.

2 Reinstall the Sensor or Window

A Insert the replacement sensor cable into the cavity and feed through to the pedestal.

B From the pedestal below, pull on the sensor cable to pull the remaining cable through.

C Install and tighten the three sensor screws.

D Connect the sensor cable terminals.

E Before reinstalling the window plate, window and gasket, make sure the spring clip lever on the quick release body is pushed in (open). This lever will click and lock in the open position.

F Position the window gasket over the sensor making sure the sensor eyes align to the gasket holes.

G Insert the window into the window plate assembly and insert the assembly pins through the gasket. Press firmly on the outer edge of the plate assembly until it clicks (locks) into position.

H Reinstall the window release set screws on the underside of the sprayhead.

Infrared (IR) - Valves (24V Plug-In Transformer) - Prior to February 1, 2013

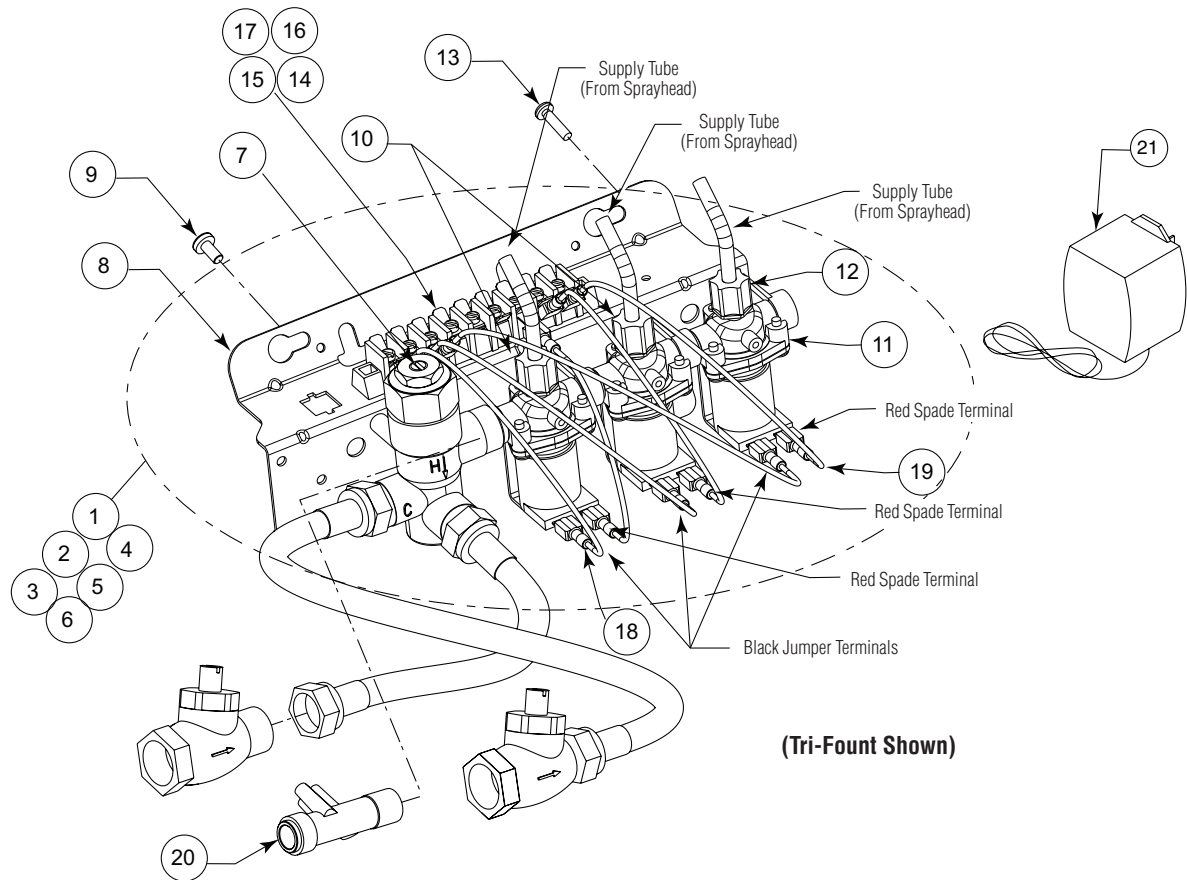

Solenoid Assembly and Valve Parts List

Item	Part No.	Description	Corner Qty	Tri Qty	Quad Qty
1	S45-2138	IR TMA Dual Valve Assembly (includes 7-19)	1	—	—
2	S45-2139	IR TL Dual Valve Assembly (includes 8-20)	1	—	—
3	S45-2140	IR TMA Tri Valve Assembly (includes 7-19)	—	1	—
4	S45-2141	IR TL Tri Valve Assembly (includes 8-20)	—	1	—
5	S45-2142	IR TMA Quad Valve Assembly (includes 7-19)	—	—	1
6	S45-2143	IR TL Quad Valve Assembly (includes 8-20)	—	—	1
7	S01-524	Vernatherm Valve, 4 GP	1	1	1
8	140-928	Bracket, Ganged Valve	1	1	1
9	P18-054	Screw 10-24 x 3/8 PN	2	2	2
10	S07-068A	Solenoid Valve, 24 VAC, Through	1	2	3
11	S07-068	Solenoid Valve, 24 VAC, Closed	1	1	1
12	110-231	Compression Nut, 1/4"	2	3	4
13	160-447	Screw 8-16 x 5/8 PN	2	3	4
14	269-625	Terminal Block	1	1	—
15	269-647	Terminal Block	—	—	1
16	160-329	Screw (Terminal Blk)	2	2	2
17	161-069	Nut (Terminal Blk)	2	2	2
18	S53-128	Wire Assy (Black)	2	3	4
19	S53-129	Wire Assy (Red)	2	3	4
20	S39-685	Adapter, Valve Inlet	1	1	1
21	S83-134	Transformer	1	1	1

Infrared (IR) Solenoid Valve Parts Assembly and 24V Plug-in Transformer - Prior to May 7, 2007

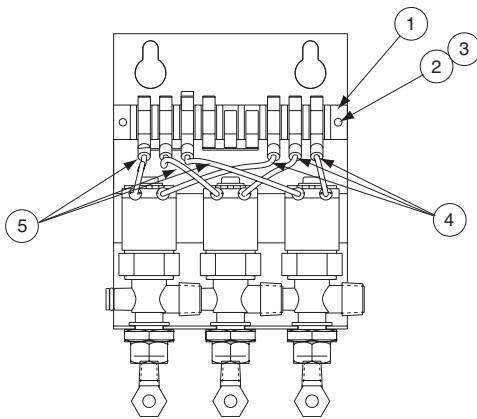

Solenoid Valve Assembly

Solenoid Assembly Parts List

Item	Part No.	Description	Corner Qty	Tri Qty	Quad Qty
*	S08-341	2 Valve Assy. with Bracket	1	—	—
	S08-298	3 Valve Assy. with Bracket	—	1	—
*	S08-299	4 Valve Assy. with Bracket	—	—	1
1	269-625	Terminal Block (2 or 3 Valve)	1	1	—
1	269-647	Terminal Block (4 Valve)	—	—	1
2	160-329	Screw 6-32 x 3/8 Round Head	2	2	2
3	161-069	Nut 6-32 Lock	2	2	2
4	S53-129	Wire Assembly Red	2	3	4
5	S53-128	Wire Assembly Black	2	3	4
6	S83-134	Transformer 24VAC (269-901 w/o connectors)	1	1	1

* Not Illustrated

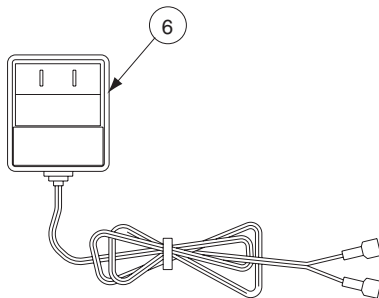

24V Plug-In Transformer

Infrared (IR) Valve Assembly - Solenoid Valve S07-068 (Closed Body) and S07-068A (Thru Body) Prior to February 1, 2013

Solenoid Valve Parts List

Item	Part No.	Description	Qty
1	118-307	Valve Body, 1/4" Closed	1
1	118-307A	Valve Body, 1/4", Through	1
2	269-983	Diaphragm	1
3	269-577	Armature	1
4	269-578	Spring	1
5	269-1729	Armature Housing	1
6	269-1730	clamp, Armature Housing	1
7	269-579	Coil, Solenoid Valve	1
8	160-447	Screw #8 x 5/8	3
9	125-165	O-Ring, #2-013	1
10	125-160	Flow Restrictor, 0.5 GPM	1
11	S65-113	Repair Kit	1

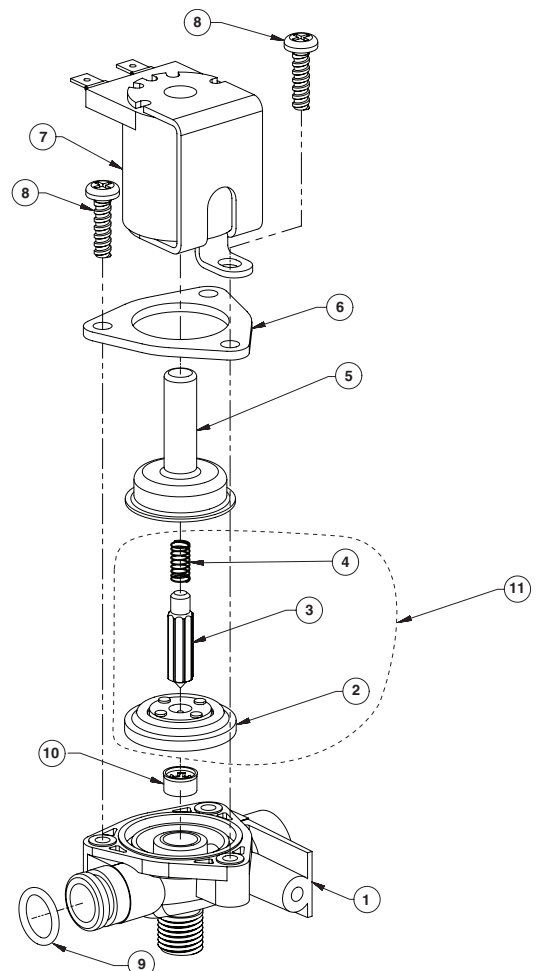

Infrared (IR) - Solenoid Valve S07-040 Individual (End), S07-041 Ganged - Prior to May 7, 2007

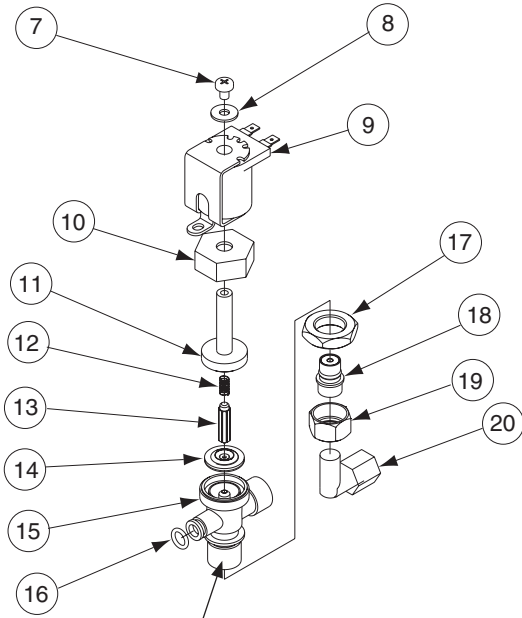

S07-040 Solenoid Valve (Individual)
 Used by itself, or as the last one (opposite end of the water inlet) in a group.

S07-041 Solenoid Valve (Ganged)
 Used in a group, except the last in line. Body is drilled to allow water to pass through into the next in line. This valve includes O-Ring 125-145 to seal to the next valve.

Solenoid Valve Parts List

Item	Part No.	Description	Corner Qty	Tri Qty	Quad Qty
	S07-040	Valve Individual	1	1	1
	S07-041	Valve Ganged	1	2	3
7	160-066	Screw 10-24 x 1/4 Round Head	2	3	4
8	124-002AZ	Washer Stainless Steel	2	3	4
9	269-579	Coil - Solenoid Valve	2	3	4
10	110-094	Nut - Bonnet	2	3	4
11	121-028	Bonnet	2	3	4
12	269-578	Spring	2	3	4
13	269-577	Armature	2	3	4
14	269-580	Diaphragm	2	3	4
15	118-237	Valve Body Individual	1	1	1
15	118-238	Valve Body Ganged	1	2	3
16	125-145	O-Ring (for ganged valve body only)	1	2	3
17	110-224	Nut 3/8-18 Hex Brass	2	3	4
18	S88-065	Tailpiece Assembly	2	3	4
19	110-195	Tailpiece Nut	2	3	4
20	145-090	Elbow	2	3	4

Infrared (IR) Sensor and Valve Troubleshooting

If a station is not functioning properly it is most likely either the solenoid valve or the sensor.

Troubleshooting multi station units is fairly easy, as you can swap parts (actually just by changing the wires) and use the process of elimination to figure out which of the 2 parts is causing the problem.

How the system operates:

1. The transformer sends 24 volts to the sensor.
2. The sensor acts only as a switch.
3. When hands go into the active field of the sensor, the sensor activates and sends a power signal on to the solenoid valve.
4. The power signal activates and opens the solenoid valve which allows the water to flow to the sprayhead. The solenoid valve stays open allowing water to flow as long as it is receiving a signal from the sensor (hands remain in the active field).
5. When hands are removed from the active field, the sensor turns off (note some models have a slight delay feature built-in) and shuts off the power signal to the solenoid valve.



The solenoid valves will be in-line and will be in the same order as the stations (in other words the center solenoid will operate the center station, the right solenoid will operate the right station).

Complaint: The center station will not shut off.

1. Disconnect the sensor wires to the center solenoid valve and set them out of the way.
2. Disconnect the sensor wires to the left solenoid valve. Set these wires out of way and make sure they will not make contact with each other or any metal or framework.
3. Connect the wires from the center solenoid valve and connect them to the left solenoid valve.
4. Reconnect the transformer to the wall outlet for power.
5. Use your hands to activate the center station and watch for the water to come out at the left station.

Conclusion:

If the left station works and shuts off, then we know that the **solenoid is the problem** in the center station.

If the **left station does not shut off**, then we know it is the **sensor** in the center station that **is causing the problem**.

Solution:

If the Sensor is the Problem it will have to be replaced. It cannot be repaired or adjusted in any way.

If the Solenoid Valve is the Problem it is most likely due to debris between the valve seat and diaphragm. This happens frequently in new and recent plumbing installations.

Take the solenoid valve apart and clean. Disconnect the wires from the solenoid. Loosen and remove the screw on top of the coil of the solenoid valve. Unscrew the bonnet nut (counterclockwise) and tip forward to remove from the valve body. Remove the diaphragm (269-580). Remove any particles that may have been trapped between the diaphragm and the valve seat. Rinse off the diaphragm and inspect for damage. Make sure both orifices in the diaphragm are open.

Reassemble and retry the solenoid valve. If there is still a problem, replace the solenoid valve.

If ordering replacement solenoid valves, be careful to order correctly, either an "individual" or a "ganged" solenoid valve.

AST4 Streamformer and Push Button Parts and Replacement - Prior to February 1, 2013

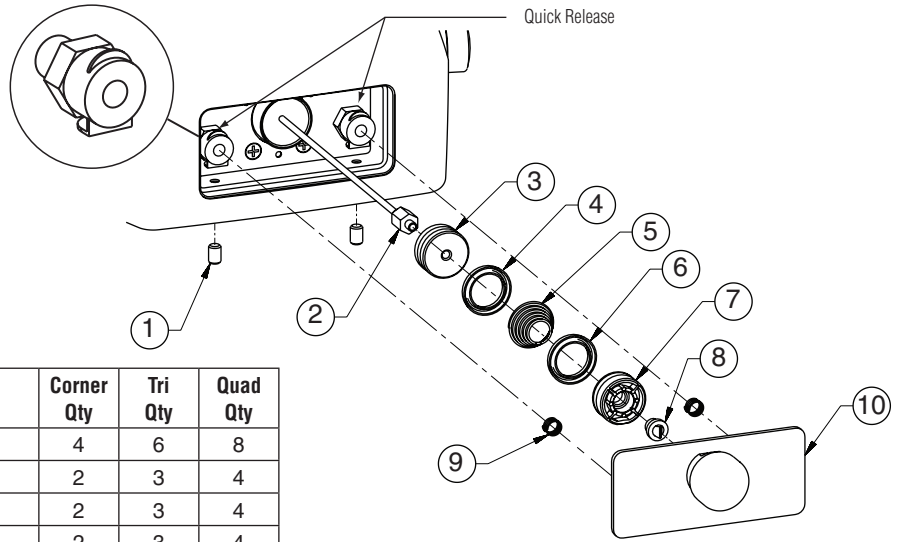

AST4 Push Button Parts List

Item	Part No.	Description	Corner Qty	Tri Qty	Quad Qty
1	160-246	Screw, Set 1/4 x 20	4	6	8
2	169-890	Tube Connector	2	3	4
3	118-313	Plug	2	3	4
4	125-157	O-Ring	2	3	4
5	135-065	Spring	2	3	4
6	125-099	U-Cup	2	3	4
7	119-227A	Piston	2	3	4
8	198-010	Check Valve - Duckbill	2	3	4
9	135-049	Spring - Window Plate	4	6	8
10	S83-156	Push Button ASM Air	2	3	4

AST4 Push Button

1 Remove the Push Button Assembly

A Use an 1/8" allen wrench to remove the window release set screws, located under the sprayhead. This allows access to the release holes under the sensor.

B Gently push the allen wrench into one of the release holes until the spring clip lever on the quick release clicks open. Repeat for the other spring clip. This will release the push button plate.

C Remove the push button, piston, U-cup (located on piston) and spring.

D In order to access the tube connector it is first necessary to remove the brass plug. Carefully insert a #8-32 threaded screw into the center of the plug and pull it out, exposing the connection tube end.

E Disconnect the tubing connector from the air line.

2 Reinstall the Push Button Assembly

A Connect the air line to the tubing connector, and fit the plug, piston and spring into the housing.

B Insert the replacement push button into the cavity.

C Before reinstalling the button plate, make sure the spring clip levers on the quick release are locked open as outlined above.

D Insert the button plate assembly pins through the gasket. Press firmly on the outer edge of the plate assembly until it clicks (locks) into position.

E Reinstall the button release set screws on the underside of the sprayhead.

90-75 Sprayhead and Streamformer Parts - Prior to May 7, 2007

90-75 Sprayhead Valve Assembly

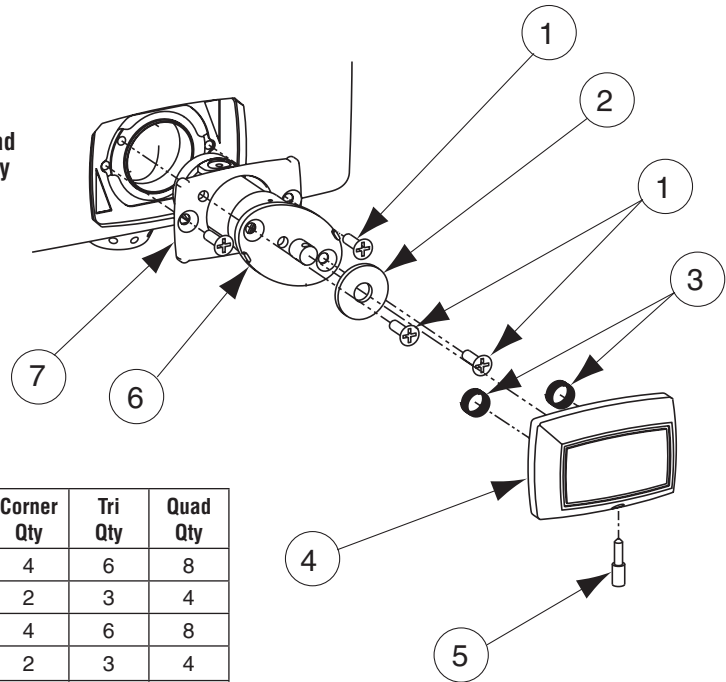

90-75 Sprayhead Valve Assembly Parts List

Item	Part No.	Description	Corner Qty	Tri Qty	Quad Qty
1	P10-132	Screw 8-32 x 1/2, Phillips Flat Head	4	6	8
2	124-047	Washer, Flat Compressed Foam	2	3	4
3	135-054	Spring, Push Button	4	6	8
4	269-186	Push Button, Multi-Fount	2	3	4
5	160-300	Screw, Set (Push Button)	2	3	4
6**	S65-084	Repair Kit - Multi-Fount (replacement cartridge)	-	-	-
7	150-116	Celcon Flange 90-75 MF	2	3	4
8*	S65-067	Push Button Service Kit MF (Includes Items 3, 4, and 5)	-	-	-

* Not Illustrated

** See following page for breakdown.

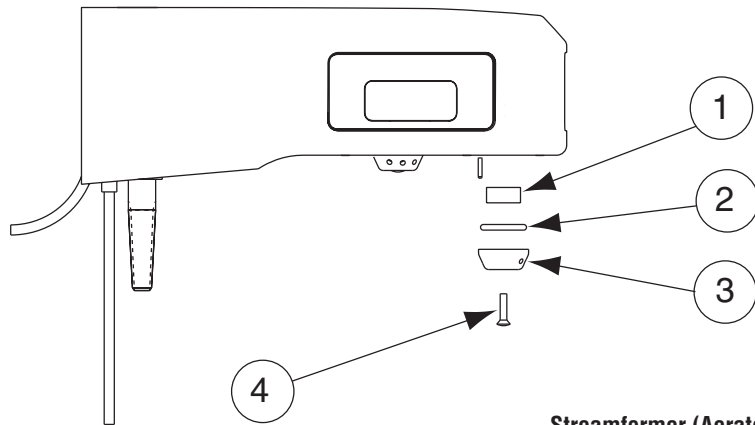

**Streamformer (Aerator)
(Side View)**

Streamformer Assembly Parts List

Item	Part No.	Description	Corner Qty	Tri Qty	Quad Qty
1	269-508	Sprayhead Diffuser MF	4	6	8
2	125-001EG	O-Ring	-	-	-
3	115-125	Streamformer	2	6	8
4	160-246	Screw 8-32 x 3/4, Oval Head	2	6	8

AST4 Air Metering Valve Parts and Troubleshooting - Prior to February 1, 2013

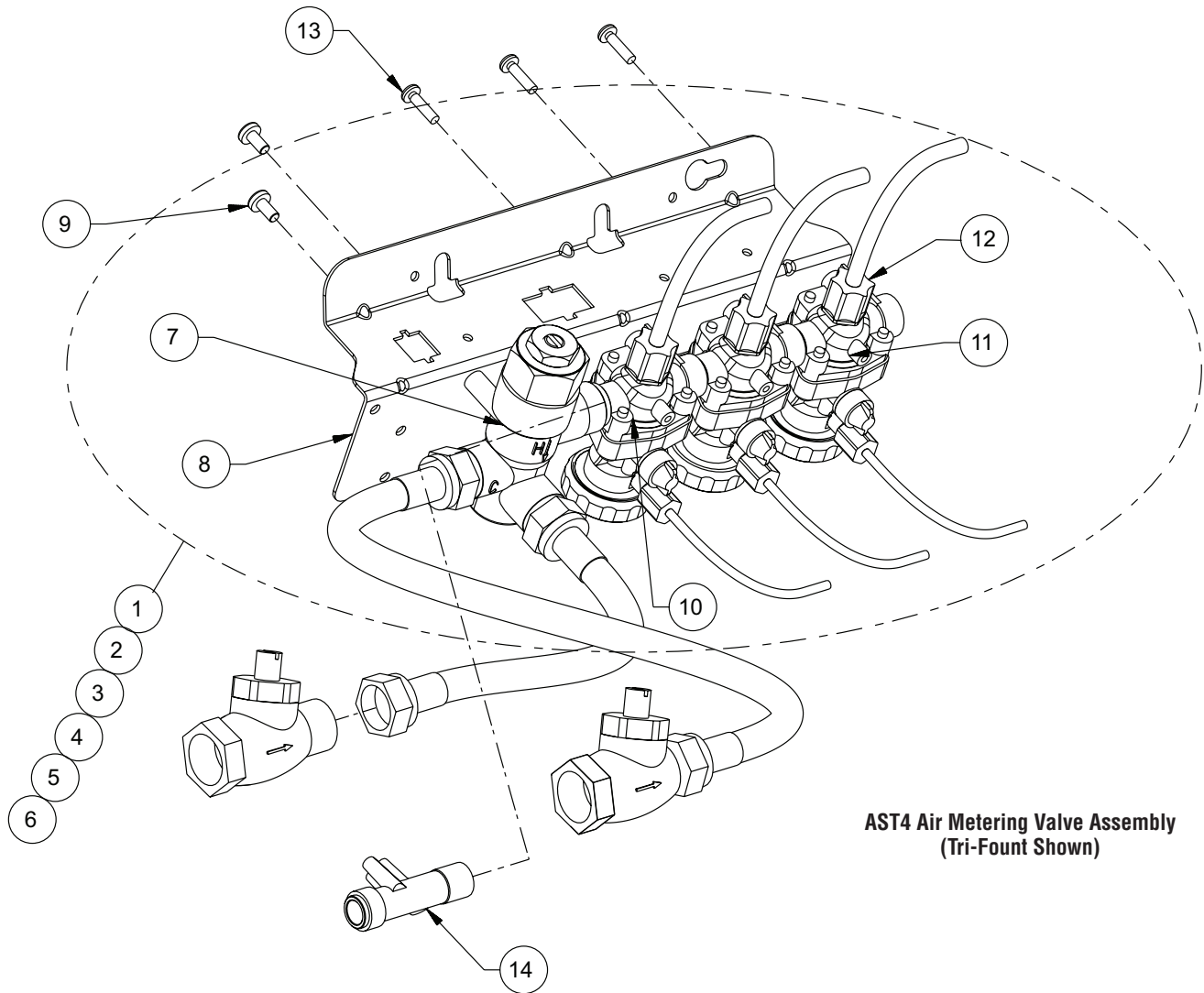

**AST4 Air Metering Valve Assembly
(Tri-Fount Shown)**

AST4 Air Metering Valve Assembly Parts List

Item	Part No.	Description	Corner Qty	Tri Qty	Quad Qty
1	S08-452TMA	TMA Dual Valve Assembly (includes 7-13)	1	—	—
2	S08-452TL	TL Dual Valve Assembly (includes 8-14)	1	—	—
3	S08-453TMA	TMA Tri Valve Assembly (includes 7-13)	—	1	—
4	S08-453TL	TL Tri Valve Assembly (includes 8-14)	—	1	—
5	S08-454TMA	TMA Quad Valve Assembly (includes 7-13)	—	—	1
6	S08-454TL	TL Quad Valve Assembly (includes 8-14)	—	—	1
7	S01-520	Vernatherm Valve, 4 GP	1	1	1
8	140-928	Bracket, Ganged Valve	1	1	1
9	P18-054	Screw 10-24 x 3/8 PN	2	2	2
10	S07-078A	AST4 Valve, Through	1	2	3
11	S07-078	AST4 Valve, Closed	1	1	1
12	110-231	Compression Nut, 1/4"	2	3	4
13	160-447	Screw 8-16 x 5/8 PN	2	3	4
14	S39-685	Adapter, Valve Inlet	1	1	1

90-75 Metering Valve Parts and Troubleshooting - Prior to May 7, 2007

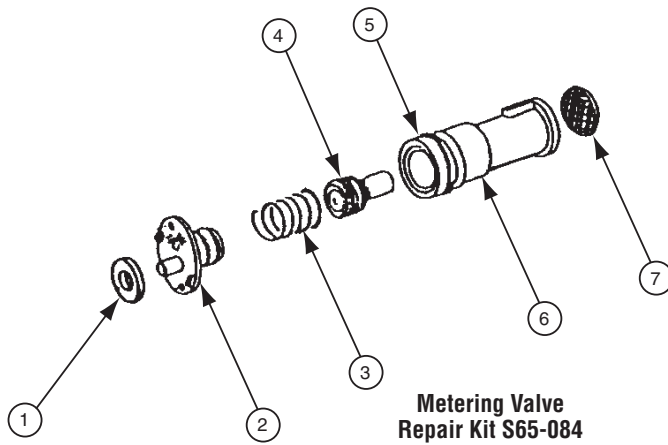

Metering Valve Repair Kit S65-084 Parts List

Item	Part No.	Qty.	Description
1	124-047	1	Soap Guard Washer
2	S73-043	1	Upper Valve Body Assembly
3	135-033	1	Spring
4	S64-089	1	Plunger Assembly
5	125-001DD	1	O-Ring
6	S73-031	1	Lower Valve Body Assembly
7	156-010	1	Filter Disk

For areas with poor water quality, use **S65-116 mega orifice cartridge**. Use the mega orifice cartridge if you have frequent “won’t turn off” complaints. Poor water quality will cause mineral build-up in the valve which will restrict the flow and proper operation of the valve.



The standard cartridge provides a 10-12 second timing cycle. The mega orifice cartridge provides only a 5-7 second timing cycle. The standard cartridge can be changed to the mega orifice by changing the plunger in the standard cartridge to the S65-091 plunger.



The shorter cycle time of the mega orifice cartridge is not acceptable by ADA standards.

Metering Air Valve Maintenance and Troubleshooting - Prior to February 1, 2013

 The air valve timer is located next to the tube connector on the air valve body. The timer is capped with a filter to prevent dirt build-up on the timer. The air valve timing can be adjusted from 5–60 seconds.

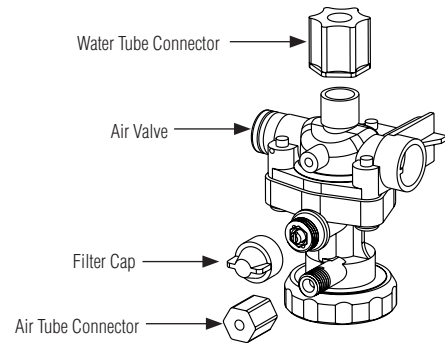

Problem	Cause	Solution
	Air valve meter time needs adjusting.	Adjust air valve meter time: 1. Remove filter cap and use a screwdriver to tighten or loosen the timer (see illustration above). Turning the timer clockwise increases the time; turning the timer counterclockwise decreases the time. 2. Continue to adjust until the timer is set at desired length. 3. Replace filter cap over the timer.
Valve will not shut off.	Timing mechanism is clogged.	Clean and inspect timing mechanism: 1. If compressed air is available, blow water and debris from timer cover of timing mechanism. 2. Turn adjusting screw out all the way. Clean and inspect screw and valve body. 3. Turn adjusting screw in to desired cycle time.
Valve will not turn on.	Water is not being supplied to unit.	Open all stops on mixing valve.
	Water pressure is over 80 PSI.	Install a pressure reducing valve.
	Failed diaphragm/magnet assembly.	Unscrew the valve clamp nut on valve. Remove valve cover. Gently press the diaphragm. The valve should activate. If not, replace the diaphragm/magnet assembly.
Timing can not be adjusted for more than 5 seconds.	There is an air leak.	Check the valve assembly: 1. Check all tubing and fittings for proper assembly. 2. Tighten cap and nut on 1/8" tubing.
Push button does not work properly.	Air volume may not be sufficient to operate valve.	Check for leaks and lubricate U-cup: 1. Check all fittings for air leaks. 2. Disassemble push button and lubricate U-cup seal.
Water is dripping from the streamformers.	Debris has accumulated on valve seat or orifices.	Clean and inspect valve seat. 1. Remove screws and disassemble metering valve. 2. Clean valve seat and inspect for deep gouges or scratches. Replace valve body if necessary. 3. Remove any debris clogging off-center hole in rubber diaphragm.

Adjust Metering Valve Timing - Prior to May 7, 2007

The metering valves have been factory tested and adjusted to provide a 10-12 second flow of water from the sprayhead, using 75-85 PSIG pressure and ambient cold water. Varied pressure and/or temperature will affect the length of the timing cycle as follows:

- Lower inlet pressure will cause a slight increase in the length of the cycle
- Higher water temperature will cause a slight decrease in the length of the cycle. If further adjustment is needed:

A Using a 3/32" Allen wrench, loosen the set screw in the bottom of the vandal-resistant push button and lift off the push button.

B Insert a 5/64" Allen wrench into the timing adjustment screw located directly in front of the operating stem. Turn the screw clockwise to shorten the cycle or counterclockwise to lengthen the cycle.

C Reinstall the push button into the sprayhead and tighten the set screw.

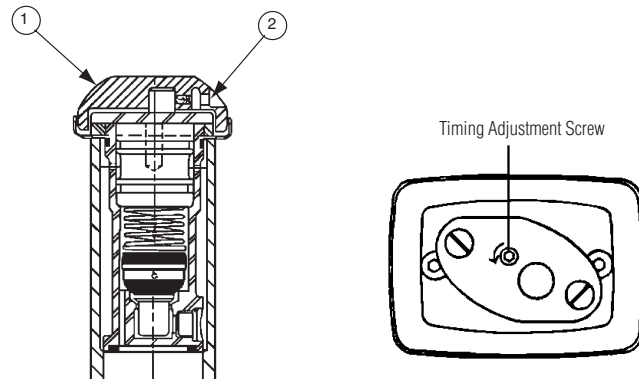

Push Button

S65-067 Push Button Kit Parts List

Item	Part No.	Description	Qty
1	269-186	Push Button	1
2	160-300	Set Screw	1
*	135-054	Spring (Under Push Button)	2

* Not Illustrated

90-75 Metering Valve Parts and Troubleshooting - Prior to May 7, 2007

Problem	Cause	Solution
Water just dribbles or does not flow from sprayhead.		<p>Turn off water supplies to washfountain</p> <ol style="list-style-type: none"> 1. Inspect check valves for proper installation. 2. Open the stops and clean the strainers, if necessary. <p>Check metering valve in sprayhead</p> <ol style="list-style-type: none"> 1. Using a 3/32" Allen wrench, remove the set screw in the bottom of the vandal-resistant push button and remove the push button. 2. Remove the upper valve body. 3. Inspect the plunger seat washer and lower valve body for debris. Clean, if necessary. 4. Inspect the bottom filter disc on the lower valve body for damage or improper placement. <p> <i>When replacing the filter disc on the lower valve body, place three small dabs of grease on the bottom of the lower valve body to hold the filter disc during installation. Do Not block the ports on the bottom of the valve body!</i></p> <ol style="list-style-type: none"> 5. Lubricate the plunger with grease. 6. Reinstall the upper valve body and push button. Tighten the set screw.
Water sprayhead delivers all hot or cold water.		<p>Turn off water supplies to washfountain</p> <ol style="list-style-type: none"> 1. Inspect check valves for proper installation. 2. Open the stops and clean the strainers, if necessary. 3. Inspect the mixing valve for proper installation. <ul style="list-style-type: none"> • Hot inlet is marked with red paint (see page 10 Service Suggestions)
Water flows continuously from sprayhead.		<p>Inspect sprayhead for sticking push buttons</p> <ol style="list-style-type: none"> 1. Using a 3/32" Allen wrench, remove the set screw in the bottom of the vandal-resistant push button and remove the push button. 2. Wait 20 seconds. If the valve shuts off, inspect the cavity for debris and clean, if necessary. 3. If flow continues, replace the Metering Valve with Repair Kit #S65-084. 4. Reinstall the push button and set screw.

90-75 Cartridge Replacement

1 Remove the 90-75 Cartridge

 Turn off the water supply before attempting to change the cartridge.

A Remove the set screw (3/32" Allen wrench) located on the bottom of the push button and remove the push button.

B Remove the two flat head screws located in the face of the cartridge.

C Rotate the cartridge 90° and wiggle slightly as you pull the cartridge out of the sprayhead.

 Watch for the round filter disk located on the back side of the cartridge to be sure it comes out with the cartridge. If this filter disk remains stuck in the cavity, use a screwdriver to remove it.

2 Replace the 90-75 Cartridge

A Place three small dabs of grease (provided in the kit) on the back side of the cartridge to hold the filter disk in place while installing. Be sure not to block ports on the bottom of the cartridge.

C Rotate the cartridge to align the screw holes and reinstall the flat head screws.

B Insert the cartridge into the cavity with screw holes rotated 90°. This will make it easier to locate the cartridge seat (filter disk).

D Reinstall the push button and set screw.

AST4, TT & IR Supply and Mixing Valve - Floor and Wall Mounted - Prior to February 1, 2013

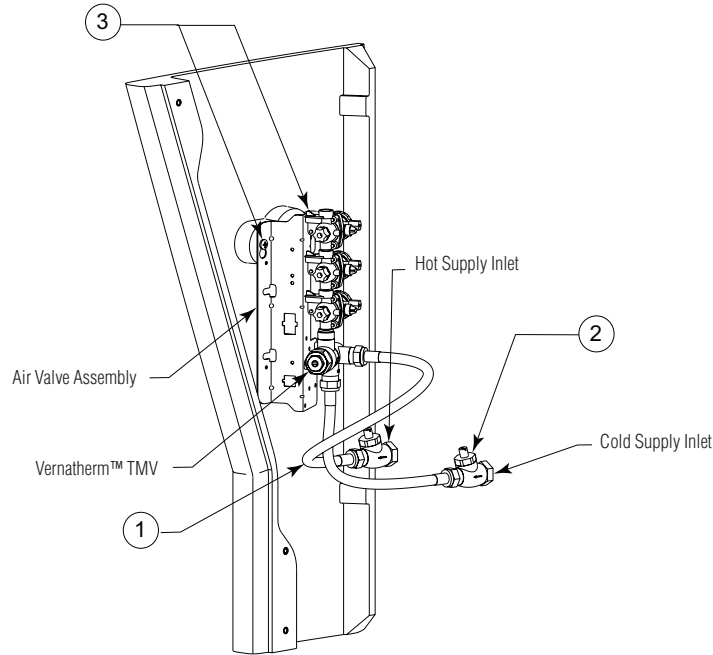

**AST4, TT & IR Supply and Mixing Valve - Floor Mount
(Tri-Fount Shown)**

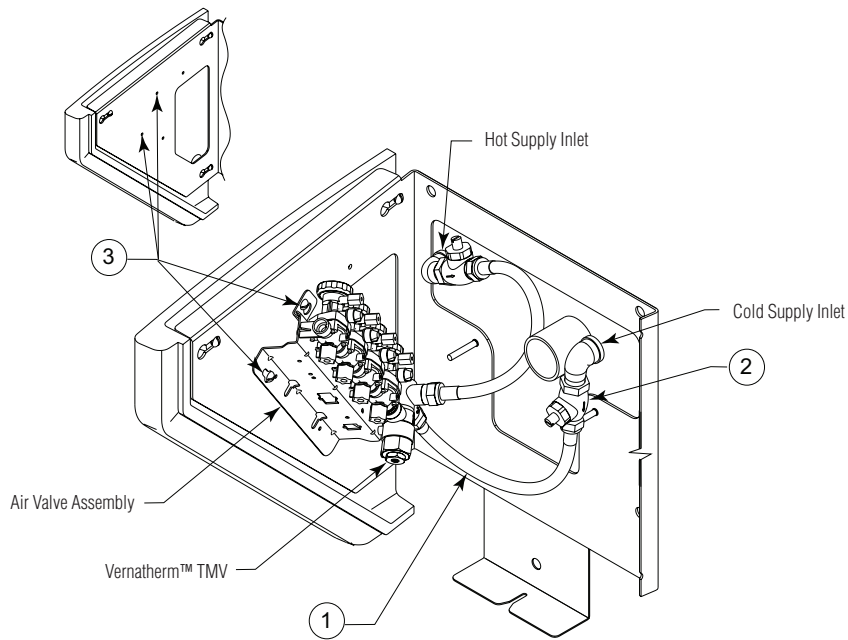

**AST4, TT & IR Supply and Mixing Valve - Wall Mount
(Quadra-Fount Shown)**

Supply Parts List

Item	Part No.	Description	Corner Qty	Tri Qty	Quad Qty
1*	269-1735	Flex Hose 1/2" NPT x 24" (Supply to TMV)	2	2	2
2*	S27-102	Check Stop	2	2	2
3	160-169	Screw	2	2	2

* Use Qty 1 for TL option, all models.

Supply and Mixing Valve Parts - Prior to May 7, 2007

Supply Tempered Line Parts List

Item	Part No.	Description	Corner Qty	Tri Qty	Quad Qty
1	S27-102	Check Stop	1	1	1
2	169-639	Fitting 90° Street Elbow	1	1	1
3	269-1188	Filter Washer	1	1	1

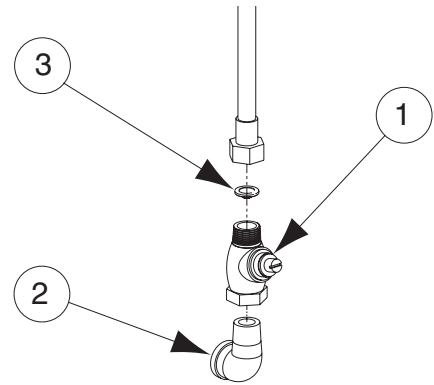

Supply Tempered Line

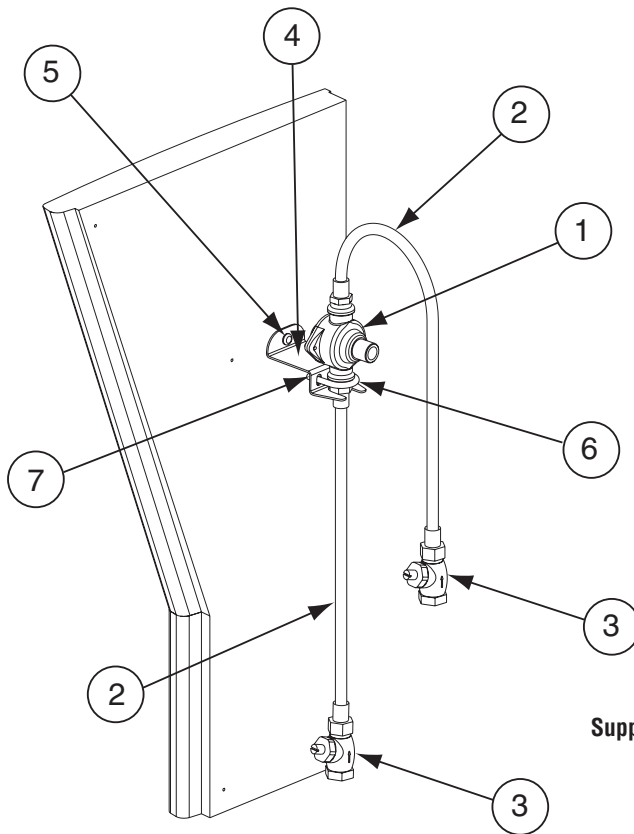

Supply Thermostatic Mixing Valve

Supply Thermostatic Mixing Valve Parts List

Item	Part No.	Description	Corner Qty	Tri Qty	Quad Qty
1	S01-116B	Thermostatic Mixing Valve - Vernatherm	1	1	1
2	269-653	Flex Hose 1/2" NPT x 24" (Supply to TMV)	2	2	2
3	S27-102	Check Stop (Use with TMV)	2	2	2
4	140-889	Bracket TMV	1	1	1
5	160-169	Screw	1	1	1
6	269-1248	U-Bolt	1	1	1
7	161-026	Nut (for U-Bolt)	2	2	2
8*	269-1365	Braided Flexible Hose (Attaches to Outlet of Thermostatic Mixing Valve)	1	1	1
9*	269-1188	Filter Washer	2	2	2

* Not Illustrated

Supply and Mixing Valve Parts - Prior to February 1, 2013

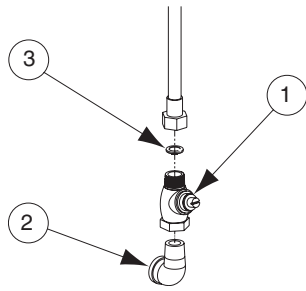

Supply Tempered Line

Supply Tempered Line Parts List

Item	Part No.	Description	Corner Qty	Tri Qty	Quad Qty
1	S27-102	Check Stop	1	1	1
2	169-639	Fitting 90° Street Elbow	1	1	1
3	269-1188	Filter Washer	1	1	1

Valve Repair Kit S65-259

Item	Part No.	Qty.	Description
5	S39-413	1	Thermostat
7	125-001BX	1	O-Ring
8	125-157	1	O-Ring

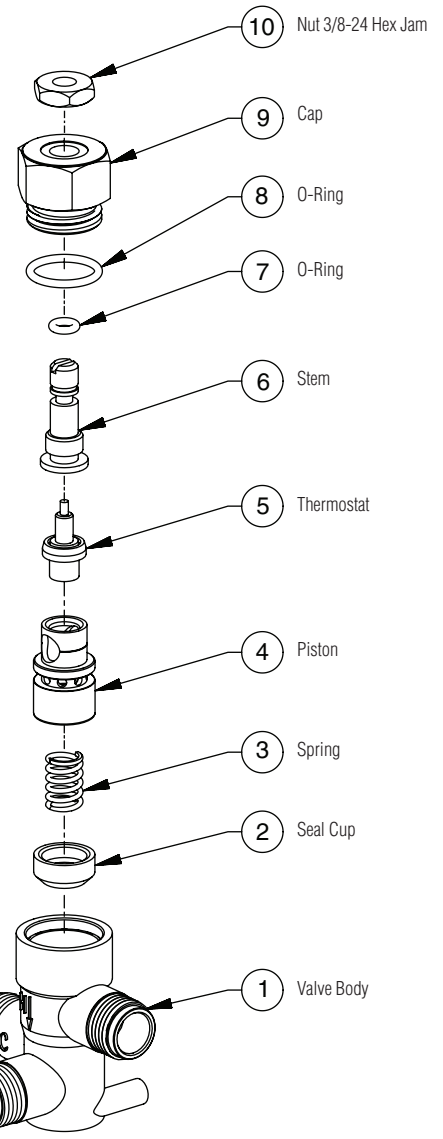

Vernatherm™ Thermostatic Mixing Valve (S01-524)

Strainer (173-028)

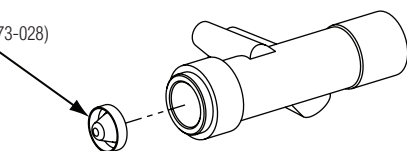

Tempered Line Adapter Assembly (S39-685) Option

Strainer (173-028)

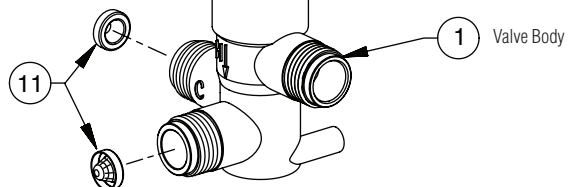

Vernatherm® Thermostatic Mixing Valve S01-116B Maintenance - Prior to May 7, 2007

Maintain Valve

A Disassemble the Vernatherm® Valve as shown, being careful not to damage the power element. Replace the element, if necessary.

B If necessary, remove the old flip ring and replace with a new ring.

An old or worn flip ring may cause temperature fluctuation and/or water chatter.

C Reassemble the power element and valve body. Apply grease to the main valve slide and gently ease into position, rotating so that grease is applied to the flip ring. Do not force the slide as this may push the flip ring from its position. To test, rotate the slide; a slight drag should be felt when correctly installed.

D Reassemble the valve.

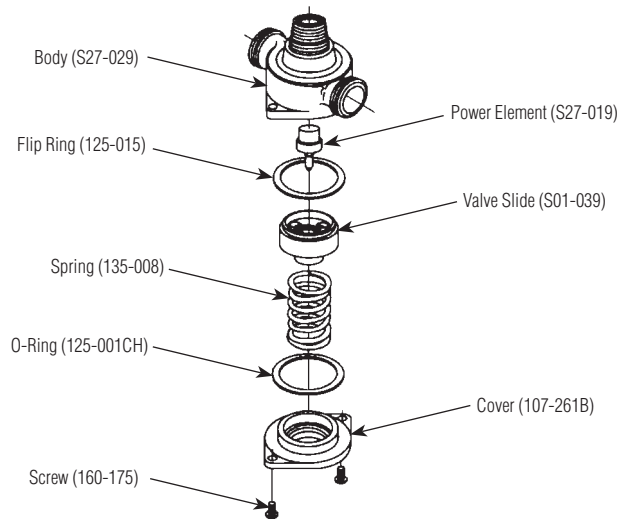

Vernatherm Thermostatic Mixing Valve S01-116B

S01-116B can no longer be ordered. If the repair kit is insufficient and the entire valve needs to be replaced, order S45-2701. Note S45-2701 has male threads on the hot and cold inlets so a 1/2" coupling is needed to use old hoses with the new valve.

S45-049 Repair Kit Parts List

Item	Part No.	Description	Qty
1	125-015	Flip Ring	2
2	135-008	Spring	1
3	S27-019	Power Element	1
4	125-001CH	O-Ring	1

Service Suggestions

When servicing the Vernatherm® valve, make sure it is installed in the correct position. The most common error that occurs is when the valve is installed in the reversed position, that is, the hot line is connected to the cold line and the cold is connected to the hot.

A red ring is painted on the hot side of the valve.

The table below lists conditions that occur when the valve is installed correctly, and when it is in the reversed position.

Valve Conditions

If			Then
Valve Position is	Hot Supply	Cold Supply	Valve Delivers
Correct	Hot	Cold	Mixed 107°
Correct	Hot	No Water	Valve shuts off or drips
Correct	No Water	Cold	Valve shuts off or drips
Correct	Hot	Hot	Hot
Correct	Cold	Cold	Cold
Reversed	Hot	Cold	Cold/Below 107° Hot/Above 107°
Reversed	Hot	No Water	Hot
Reversed	No Water	Cold	Cold
Reversed	Hot	Hot	Hot
Reversed	Cold	Cold	Cold

Soap System Parts and Maintenance Tips - Prior to February 1, 2013

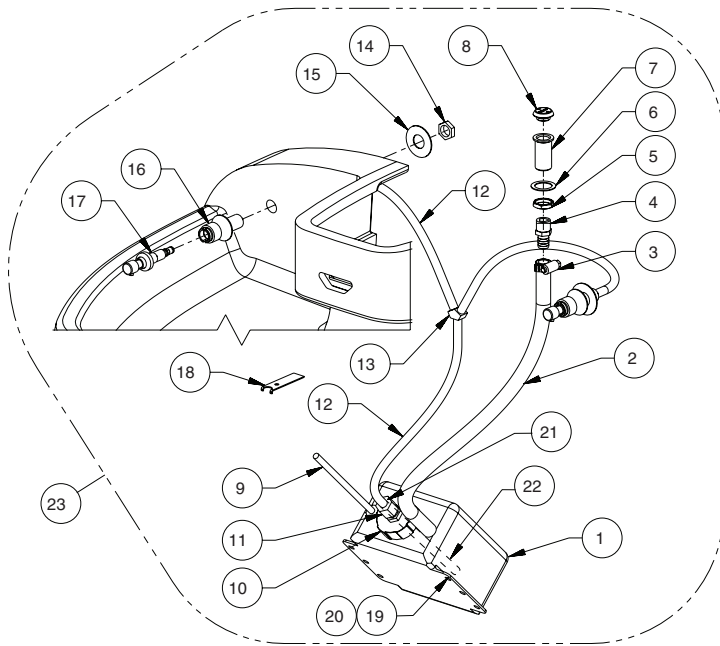

Soap System

Soap System Parts List

Item	Part No.	Description	Qty
1	240-001	Soap Tank	1
2	169-989	Hose 5/8 ID	*
3	146-040	Hose Clamp	1
4	169-916	Male Fitting	1
5	110-093	Nut	1
6	142-002CJ	Washer	1
7	153-174	Filler	1
8	136-011	Soap Filler Cap	1
9	R68-600021	Tube Vent 3/16	*
10	136-049	Soap Tank Cap	1
11	269-1832	Bulkhead Fitting	1
12	R68-800002	Tube Supply 1/2	*
13	269-1183	Tee	1
14	110-115	Nut	2
15	142-002CB	Washer	2
16	S52-109	Soap Valve Body Assembly	2
17	S09-083	Soap Valve	2
18	130-142	Soap Filler Cap Wrench	1
19	161-026	Nut	2
20	142-002AV	Washer	2
21	269-1834	Ferrule	1
22	R68-600012	Tube	*
23	S50-409	Complete Soap System (Includes Items 1-22)	1

* Specify length in feet.

Soap Valve S09-083

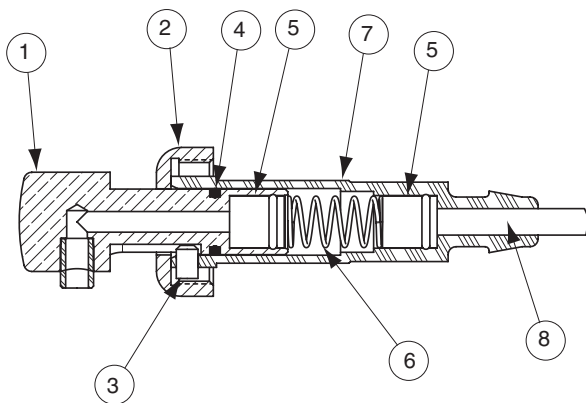
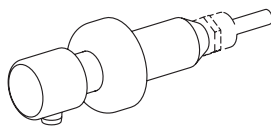

Soap Valve S09-083 Parts List

Item	Part No.	Qty.	Description
	S09-083	1	Soap Valve Complete
1	S64-096	1	Plunger Assembly
2	110-227A	1	Collar
3	160-239	1	Set Screw
4	125-168	2	O-Ring
5	198-013	1	Seat Assembly
6	135-097	1	Spring
7	144-068M	1	Cylinder
8	R68-800002	1	Tube 3/8" ID (Specify length in feet)

Soap System Parts and Maintenance Tips (continued)

Soap Recommendations

Quality soap dispensers require good quality soap and periodic maintenance to properly operate. Bradley soap dispensers will provide dependable, consistent operation over the long term when soap with reasonable viscosity and pH levels are used and when a minimal amount of periodic maintenance is performed on the valves.

Soap thickness is determined by a measurement called viscosity. Soap viscosity should be between 100 cps (centerpoise) and 2500 cps for all Bradley soap dispensers. Thinner soaps are perceived by the users as being “watered down” so users tend to take more than they need, resulting in waste. Thick soaps flow slower and inhibit the “flushing” action of the valves, which allows the soap to congeal in the valve and cause clogs.

The pH (acid) level of the soap should be in the range of 6.5 to 8.5. More acidic soaps (pH levels lower than 6.5) will corrode metal parts (even stainless steel!!) and degrade rubber and plastic components. They will also cause skin irritation. Most inexpensive soaps (typically the pink lotion type) fall into this acidic category and will eventually cause valve failure and metal corrosion. Base soaps (pH levels higher than 8.5) will cause swelling or degradation of rubber and plastic parts and skin irritation.

Generally, any quality soap meeting the viscosity and pH guidelines above will work well with Bradley soap dispensers. PCMX or Isopropanol based antibacterial soaps (within viscosity and pH limits) will also work with Bradley dispensers. Soaps satisfying these basic guidelines will provide consistent flow and reduce clogs.

Most soap dispenser problems are caused by soap that is too thick or corrosive, or by a lack of maintenance. Many soaps come in concentrate form which must be diluted with water. Often, the soap is improperly diluted or used straight out of the bottle, which causes clogging and valve failure. If proper soap is being used, valves that have never been cleaned are usually the source of dispensing problems. Bradley has entered into an agreement with Champion Brand Products to provide additional customer service for purchasers of our dispensers regarding soap issues. They are very helpful and can get to the bottom of almost any soap dispenser related problem. They also sell an excellent “Bradley approved” soap. Please see Soap Instruction Sheet 215-1286 for details about soap valve cleaning or how to contact Champion. With proper maintenance and soap, Bradley dispensers will provide long term, trouble free operation.

Soap Dispenser Maintenance Instructions for Multi-Fount Washfountains

Bradley soap dispensers will provide dependable, consistent operation over the long term when the proper soap is used and when a minimal amount of periodic maintenance is performed on the valves. Valves must be maintained (cleaned) to function properly.

To ensure proper operation of your soap dispenser, follow these instructions:

- Once per month, remove the cap from the soap tank, insert the draw tube (below the cap) into hot water and soak it for 30 minutes.
- Push valve at least 20 times while it is soaking.
- Flush soap reservoir with hot water while valve is soaking.

In cases of extreme clogging, the valve should be disassembled and the parts should be soaked in hot water or cleaning solution to restore proper functioning. Soap dispensers that will not be used for extended periods of time (schools during summer break, etc.) should be drained, cleaned and left empty until put back into service. Soap left on the outside of dispensers can cause discoloration and corrosion of the reservoir (even on stainless steel units). All soap should be wiped or scrubbed off daily, then the outside of the dispenser should be rinsed with clear water and dried with a soft cloth.

Soap System Parts and Maintenance Tips - Prior to May 7, 2007

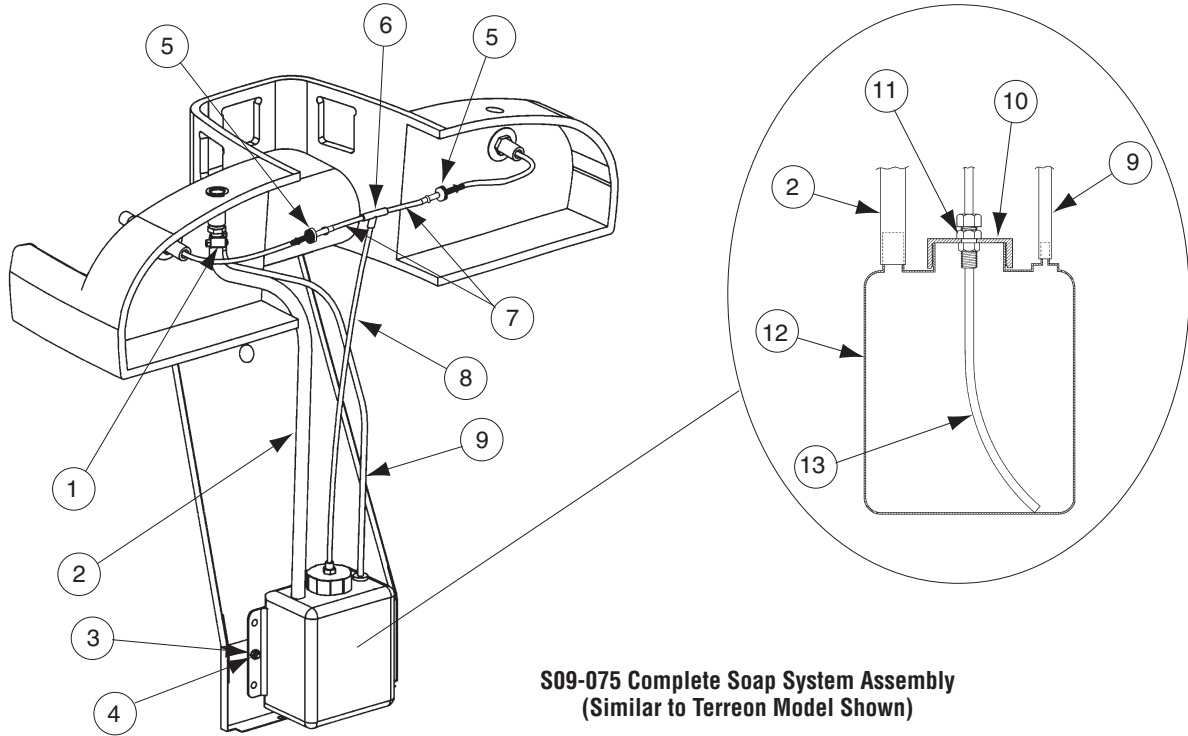

**S09-075 Complete Soap System Assembly
(Similar to Terreon Model Shown)**

S09-075 Complete Soap System Assembly Parts List

Item	Part No.	Description	Qty
1	146-040	Hose Clamp	1
2	169-989	Filler Hose	1
3	161-026	Nut	1
4	142-002AV	Washer	1
5	269-028	Check Valve	2
6	169-966	Tee	1
7	169-928	Tube 1/8" ID (Specify Length in Feet)	2
8	169-928	Tube 1/8" ID (Specify Length in Feet)	1
	S57-058	Draw Tube Assembly Includes: 5 through 8	1
9	R68-600021	Vent Tube 3/16" ID x 48"	1
10	136-031	Cap for Soap Tank	1
11	269-021	Bulkhead Fitting for Soap Tank Cap	1
12	240-001	Soap Tank	1
13	169-928	Tube 1/8" ID (Specify Length in Feet)	1
14	S09-078A	Soap Valve	2
15	S52-109	Soap Valve Body Assembly	2
16	136-011	Filler Cap	1
17	142-002CJ	Washer	1
18	110-093	Nut	1
19	153-174	Filler Body	1
20	169-916	Connector Male	1
21	130-142	Wrench for Filler Cap	1
22	110-115	Hex Nut	2
23	142-002CB	Washer	2

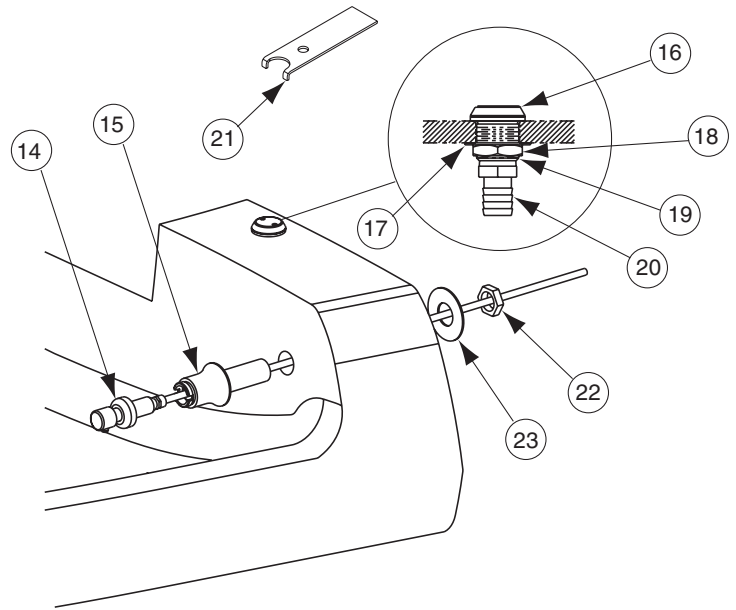

Soap System Parts and Maintenance Tips (continued)

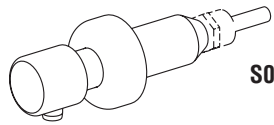

S09-078A Soap Valve

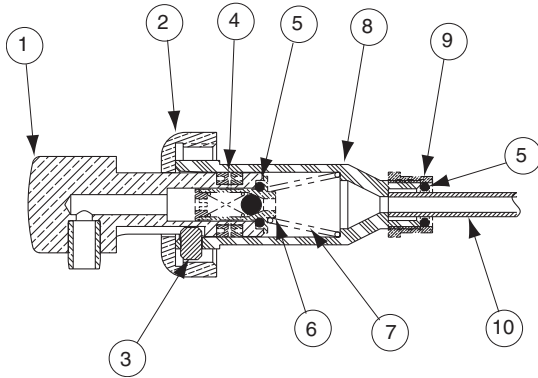

S09-078A Soap Valve Parts List

Item	Part No.	Description	Qty
1	S64-030	Plunger Assembly	1
2	110-227A	Collar	1
3	160-239	Set Screw	1
4	125-056	U-Cup	2
5	125-001DH	O-Ring	2
6	S68-004	Seat Assembly	1
7	135-035	Spring	1
8	144-043A	Cylinder	1
9	169-964	Nut	1
10	169-928	Tube 1/8" ID (Specify Length in Feet)	1

Soap Recommendations

Quality soap dispensers require good quality soap and periodic maintenance to properly operate. Bradley soap dispensers will provide dependable, consistent operation over the long term when soap with reasonable viscosity and pH levels are used and when a minimal amount of periodic maintenance is performed on the valves.

Soap thickness is determined by a measurement called viscosity. Soap viscosity should be between 100 cps (centerpoise) and 2500 cps for all Bradley soap dispensers. Thinner soaps are perceived by the users as being "watered down" so users tend to take more than they need, resulting in waste. Thick soaps flow slower and inhibit the "flushing" action of the valves, which allows the soap to congeal in the valve and cause clogs.

The pH (acid) level of the soap should be in the range of 6.5 to 8.5. More acidic soaps (pH levels lower than 6.5) will corrode metal parts (even stainless steel!!) and degrade rubber and plastic components. They will also cause skin irritation. Most inexpensive soaps (typically the pink lotion type) fall into this acidic category and will eventually cause valve failure and metal corrosion. Base soaps (pH levels higher than 8.5) will cause swelling or degradation of rubber and plastic parts and skin irritation.

Generally, any quality soap meeting the viscosity and pH guidelines above will work well with Bradley soap dispensers. PCMX or Isopropanol based antibacterial soaps (within viscosity and pH limits) will also work with Bradley dispensers. Soaps satisfying these basic guidelines will provide consistent flow and reduce clogs.

Most soap dispenser problems are caused by soap that is too thick or corrosive, or by a lack of maintenance. Many soaps come in concentrate form which must be diluted with water. Often, the soap is improperly diluted or used straight out of the bottle, which causes clogging and valve failure. If proper soap is being used, valves that have never been cleaned are usually the source of dispensing problems. Bradley has entered into an agreement with Champion Brand Products to provide additional customer service for purchasers of our dispensers regarding soap issues. They are very helpful and can get to the bottom of almost any soap dispenser related problem. They also sell an excellent "Bradley approved" soap. Please see Soap Instruction Sheet 215-1286 for details about soap valve cleaning or how to contact Champion. With proper maintenance and soap, Bradley dispensers will provide long term, trouble free operation.

Soap Dispenser Maintenance Instructions for Multi-Fount Washfountains

Bradley soap dispensers will provide dependable, consistent operation over the long term when the proper soap is used and when a minimal amount of periodic maintenance is performed on the valves. Valves must be maintained (cleaned) to function properly.

To ensure proper operation of your soap dispenser, follow these instructions:

- Once per month, remove the cap from the soap tank, insert the draw tube (below the cap) into hot water and soak it for 30 minutes.
- Push valve at least 20 times while it is soaking.
- Flush soap reservoir with hot water while valve is soaking.

In cases of extreme clogging, the valve should be disassembled and the parts should be soaked in hot water or cleaning solution to restore proper functioning. Soap dispensers that will not be used for extended periods of time (schools during summer break, etc.) should be drained, cleaned and left empty until put back into service. Soap left on the outside of dispensers can cause discoloration and corrosion of the reservoir (even on stainless steel units). All soap should be wiped or scrubbed off daily, then the outside of the dispenser should be rinsed with clear water and dried with a soft cloth.

Pedestal Assembly Parts

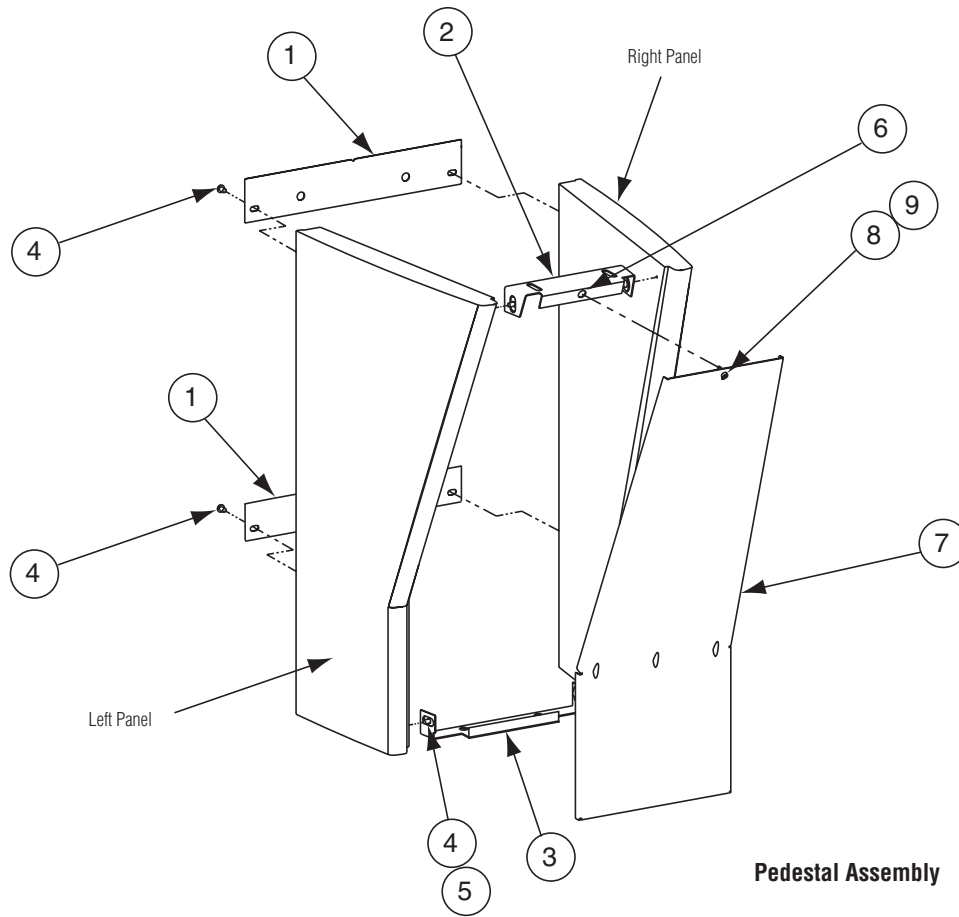

Pedestal Parts List

Item	Part No.	Description	Corner Qty	Tri Qty	Quad Qty
1	186-1589	Mounting Panel	2	–	–
1	186-1589	Mounting Panel	–	2	–
1	186-1590	Mounting Panel	–	–	2
2***	S04-056	Upper Bracket Assembly	1	1	–
2***	S04-057	Upper Bracket Assembly	–	–	1
3	140-1011	Lower Bracket	1	1	–
3	140-1012	Lower Bracket	–	–	1
4*	160-389	Screw 1/4-20	8	8	8
5*	142-002BJ	Washer	4	4	4
6	146-055	Clip	1	1	1
7	S04-100	Access Panel - Standard Height	1	1	–
7	S04-095	Access Panel - Juvenile Height	1	1	–
7	S04-101	Access Panel - Standard Height	–	–	1
7	S04-096	Access Panel - Juvenile Height	–	–	1
8**	132-031	Washer	1	1	1
9**	147-019	Screw	1	1	1

* Not Illustrated

** Access Panel (Item 7) part numbers include the screw and washer.

***Upper Bracket Assembly includes Item 6.

Replacement Pedestal Panels

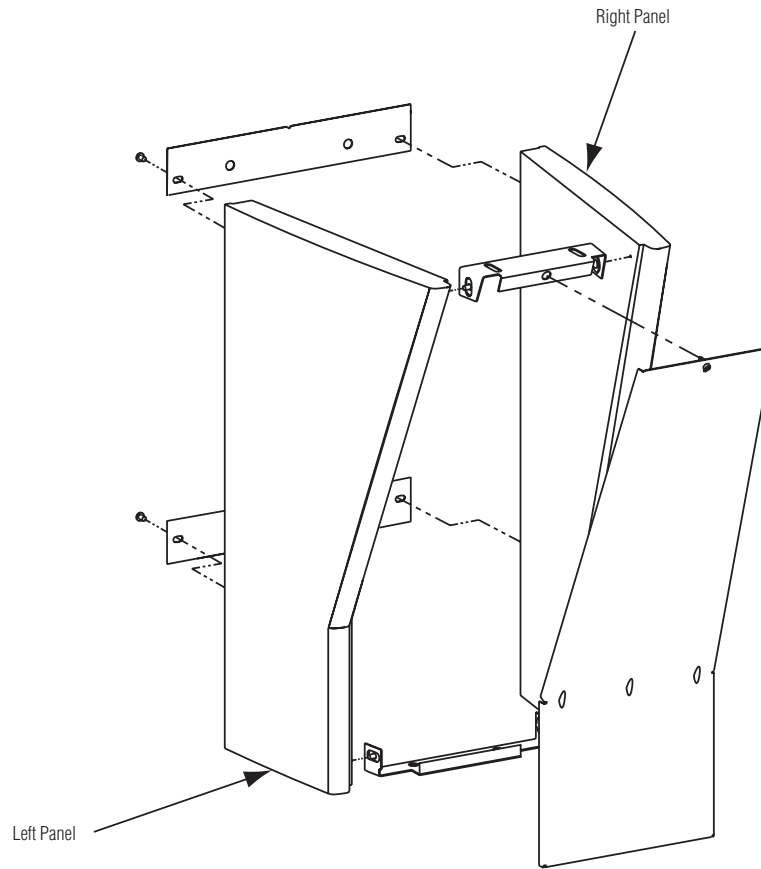

Pedestal Panels

Replacement Panel Part Numbers - MF2902, MF2903, MF2904

Color	Juvenile Height Right Panel	Juvenile Height Left Panel	Standard Height Right Panel	Standard Height Left Panel
Granito	S15-109P	S15-106P	S15-078P	S15-081P
White Marmorite	S15-110P	S15-107P	S15-079P	S15-082P
Whisper Gray	Please call Bradley for ordering information			
Dusty Rose	Please call Bradley for ordering information			

Drain Spud and Strainer Parts

 The rubber washer that comes with this kit is used for certain applications.
Discard this washer for this application as it is not used on Washfountains.

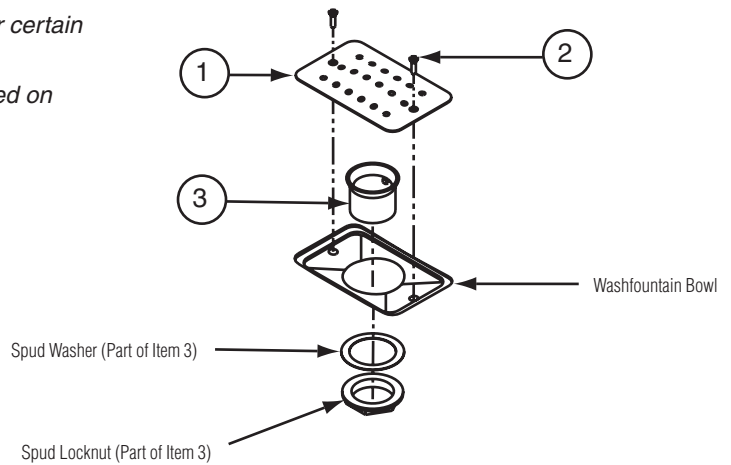

Drain Spud and Strainer Parts List

Item	Part No.	Description	Qty
1	173-023	Dome Strainer	1
2	160-248	Screw 10-24 x 1/2" (for Strainer)	2
3	112-029	Drain Spud (Includes Washer and Nut)	1

Drain Spud and Strainer

Bowl Maintenance Instructions

 The Bradley Terrazzo Multi-Fount bowl is made of a pre-cast material that has been covered with a polyurethane finish. With regular cleaning and periodic maintenance, the bowl will provide years of dependable service.

1 Clean Bowl

 Do not use scouring pads, cleansers, bowl cleaners or acidic products.

A Wipe down the bowl daily to remove soap film and residue.

B Once a week, give the bowl a thorough cleaning with any non-abrasive household cleaner, such as Lysol® Tub & Tile Cleaner.

2 Treat Bowl

A The bowl should be treated periodically with regular marine wax or a commercial product such as Marble Magic™ to maintain the bowl's shine.

B Should the bowl's clear surface finish become scratched or worn away, the bowl should be recoated to prevent damage to washfountain.

 Scratches and worn spots can be touched up with marine polyurethane, available from boat and marine supply dealers.