



AV90 Advocate® Lavatory System – AV-Series

- Soap, water and hand dryer, unique all-in-one patent pending design
- Includes infrared, high speed, dual-sided hand dryer at each hand washing station
- Includes large capacity, top-fill, infrared soap dispenser, with low level indicator and one-of-a-kind overflow protection
- Includes hygienic hands-free infrared, .38gpm faucet
- Constructed of Terreon® Solid Surface Material
- Soap, faucet and dryer are pre-mounted to basin
- Meets International Codes & Standards

Specifications

The Advocate® Lav System's unique all-in-one design allows users to access soap, water and a hand dryer without leaving the hand washing station. This provides personal space and helps to prevent water from dripping off hands and on to the floor, making cleaning and maintenance easier while providing a safer restroom environment. The AV-Series features a solid surface one-of-a-kind integral bowl. This system can be mounted at different heights to accommodate hand washing for adults, children, young children and those with disabilities.

Construction

Bowl

Constructed of Terreon, a densified solid surface material composed of bio-based resin or Terreon®RE, a densified solid surface material composed of a bio-based resin and preconsumer recycled granules. Terreon and TerreonRE are resistant to chemicals, stains, burns and impact. Surface damage can be easily repaired with everyday cleansers or fine grit abrasives.

Access Panel

The access panel of the Advocate lav system not only conceals plumbing and electrical connections, but also reduces time needed for installation and maintenance. Access panel is made from Class A fire-rated polystyrene. Access panel color: Coal.

End Panel

The end panels are deep drawn 18 gauge stainless steel. Stainless steel is polished 300 series with a #3 finish. End panels have internal stud welds for mounting to stainless steel frame described below.

Mounting Frame

The AV-Series includes welded 18 gauge stainless steel mounting frame with 14 gauge basin supports, eliminating the need for additional specifications and/or casework to support the fixture. All Advocate Lavatory Systems meet or exceed industry standards for load testing.

Faucet

The faucet sensor uses a collimated infrared transmitting beam as part of a position sensor to detect hands. Range is 4". This creates a specific detection area near the faucet spout. Sensor activates when the user's hands enter the detection area. A timing turn-off delay of 2–3 seconds results in a smooth, controlled hand-washing operation. To ensure proper activation, lighting can not exceed 10,000 lux. The Bradley sensor is not affected by varying skin tones or darkness. The flow is a spray pattern at a rate of .38 gpm.

- Low Voltage Plug-In Adapter – A UL/CSA-listed 120VAC/12VDC or 230/24 VAC, plug-in adapter powers the solenoid valve. The adapter, furnished as standard equipment, plugs into a standard GFCI protected electrical outlet.

Protected by one or more of the following patents: D663,016; D674,967. Other patents pending.

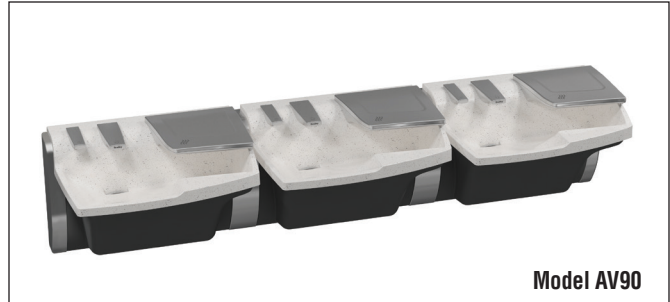

Model AV90

Valve

12VDC, 3/8" NPT electronically-activated, slow-closing solenoid valve provides reliable performance since there are few moving parts, and its operation is unaffected by most chemicals and minerals often present in municipal water supplies. Operating water pressure range is 20–80 psi. Flow regulator keeps flow rate constant at all pressures.

Soap Dispenser

Each hand washing station features an electronic liquid soap dispenser within the basin area. This eliminates any soap from dripping on counters or onto the floor, minimizing slip hazards and easy cleaning. Each dispenser features an integral check valve to hold prime for consistent reliable operation. Dispenser is top filled via a tamper resistant flip top cover accessed using a spanner wrench (included). Dispenser is compatible with most liquid soaps. Soap tank capacity is 64oz. (1893ml). The Advocate soap dispenser features built in-overflow protection utilizing an audible chirp that increases in intensity when soap level approaches full. Soap level indicator flashes red when soap is low. The sensor uses a collimated infrared transmitting beam as part of a position sensor to detect hands. Sensor activation range is 2". Intelligent electronics allow a maximum of three activations in a 15-second period, limiting the rate at which soap can be dispensed, preventing waste and deterring vandalism. Sensor can be activated at start up to automatically prime soap dispenser.

Hand Dryer

Each hand washing station features an individual infrared-activated, energy efficient hand dryer. Dryer can be entered from the side immediately after washing hands. This virtually eliminates excess water on the floor. The one-of-a-kind dual-sided dryer features white LEDs to illuminate the dryer cavity while in stand-by mode, and amber LEDs while dryer is active. Dryer sensors can be turned off for 30 seconds while cleaning dryer area. The sensor uses a collimated infrared transmitting beam as part of a position sensor to detect hands. Range is 4". The dual-sided dryer will dry hands in approximately 15 seconds. The dryer nozzles contain antimicrobial protection that inhibits the growth of microorganisms such as bacteria, mold, mildew, and fungus. Dryer motor, located inside the cabinet of the Advocate, has 3' power cord that plugs into a standard 20-amp, 120-volt outlet or 10-amp outlet for the 230-volt model. Easily accessible filter housing uses standard rigid polyester replacement air filters. Dryer has an on/off disconnect switch. Dryer must be unplugged for any service. Hand dryer requires a dedicated 20 amp circuit or 10-amp outlet for the 230-volt model, and must be properly grounded. GFI circuit protection is recommended. Hand dryer is UL listed.

AV Dryer Option Code	Voltage/ Hz	Watts	Amps	Circuit Required (Amps)	CFM	dB	Plug Type
HD2	120/60	1150	12	20	69	80	B
HD3	230/50	1150	8.6	10	70	80	F
HD4	230/50	1150	8.6	10	70	80	G



Code Compliance and Certifications

Electrical Safety - United States and Canada

- UL 507 Electric Fans
- CSA C22.2 no. 113-10 Fans and Ventilators
- UL 60730-1 Electrical Controls for Household and Similar Use, Part 1: General Requirements.
- CSA-E60730-1-02, Automatic Electrical Controls for Household and Similar Use - Part 1: General Requirements
- FCC Part 15 Subpart B Class A

Plumbing - United States and Canada

- CSA B45.0 General Requirements for Plumbing Fixtures
- B45.5/IAPMO Z124 Plastic Plumbing Fixtures
- ASME A112.18.1-2011/CSA B125.1-11 Plumbing Supply Fittings
- ASME 1070-2004 Performance Requirements for Water Temperature Limiting Devices
- IAPMO IGC 156 Washfountains and Lavatory Systems with or without Water Closets
- NSF/ANSI 372-2011 Drinking Water System Components - Lead Content

Solid Surface - United States and Canada

- CSA B45.5/IAPMO Z124 Plastic Lavatories - Home Innovation Lab Certified
- ASTM E84 Surface Burn Characteristics - Rated Flame Class A
- GREENGUARD Certified as low emitting materials.

Standard Height Mounting

The standard height hand washing stations are designed to be mounted with a 34" rim height to comply with all ADA guidelines on reaches and clearances.

Juvenile Height Mounting

The juvenile height hand washing stations are designed to be mounted at 31" rim height to comply with all ADA guidelines, and ANSI A117.1 standard, for reaches and clearances. Source: ADA Accessibility Guidelines for Buildings and Facilities (ADAAG) as amended through August 5, 2005.

Junior Height Mounting



The Junior Height option is designed to be mounted at a 26" rim height for use by younger children where ADA guidelines are not a concern.

Hand Dryer

The Advocate Lavatory System hand dryer meets requirements for safety as listed by Underwriters Laboratories, Inc.

Standard Equipment

AV90 Advocate lavatory system features three hand washing stations with hands-free .38gpm flow faucets, soap dispensers and three hand dryers. These components are composite fiberglass, reinforced polymer with a painted, clear coat finish. End panels are satin finish 300 series stainless steel. Heavy gauge stainless steel mounting system. Trap cover is easily removed for service and encloses the following fittings: offset drains; P-traps; flexible stainless steel supply connections; and ASSE 1070 Navigator® thermostatic mixing valve with combination stop/strainer/check valves.

-  This plumbing fixture is designed for hand washing only. It is not intended to dispense water for human consumption through drinking or for preparation of food or beverages.
-  Standard product selections contained within this document are third party **CERTIFIED** to NSF/ANSI 372 meeting the Lead-Free content requirement. Any product configured with custom options will be **COMPLIANT** with NSF/ANSI 372 meeting the Lead-Free content requirement.





AV90 Advocate® Lavatory System – AV-Series

Dimensions for AV-Series Advocate Lavatory Systems

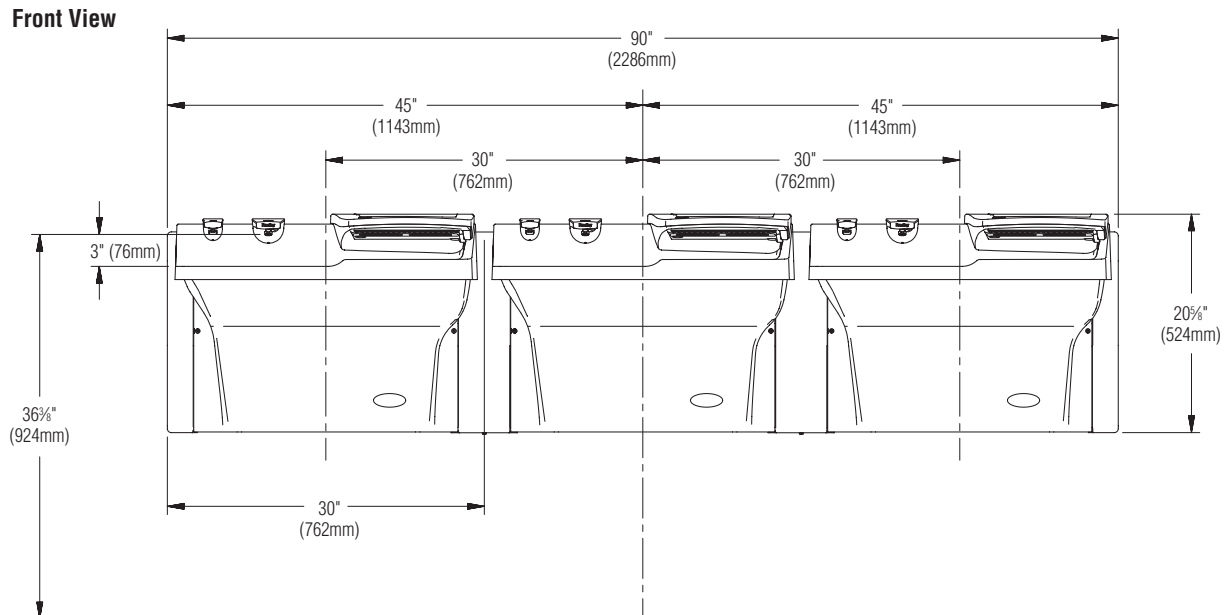
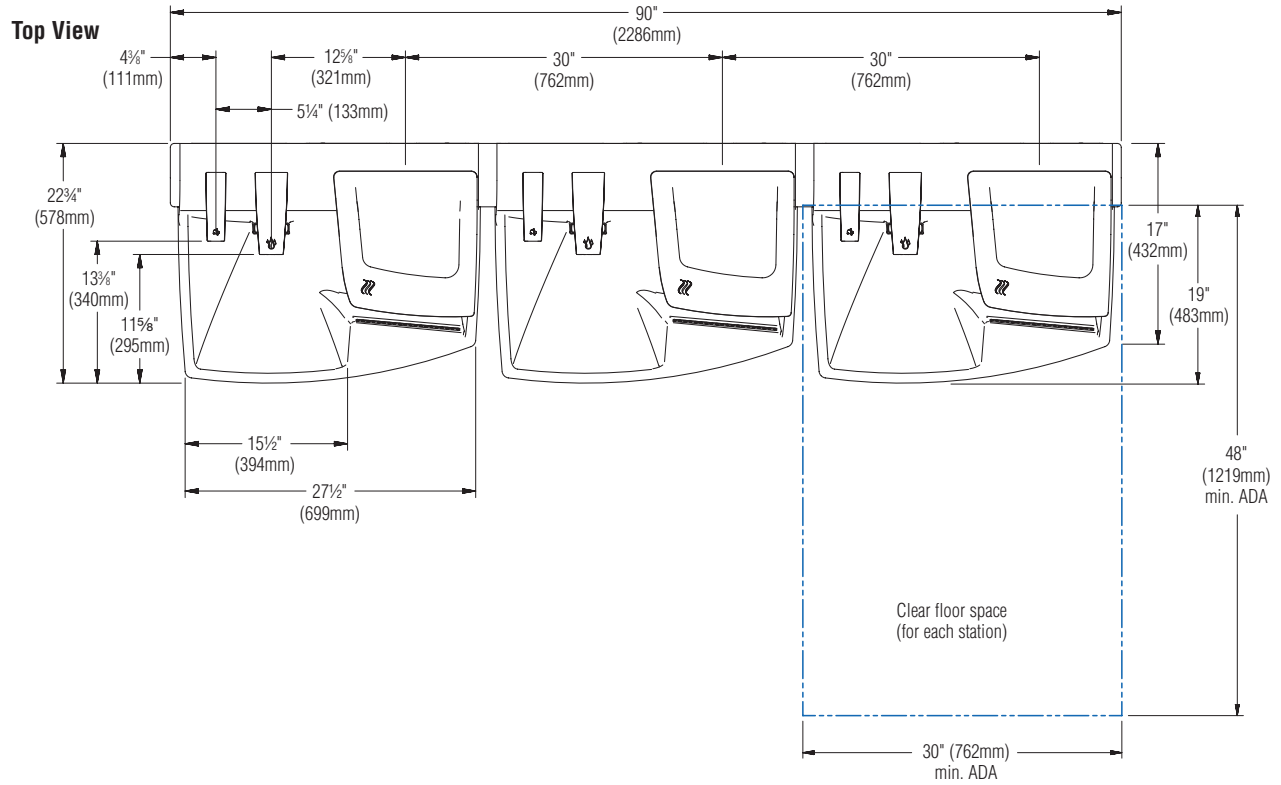



AV90 Advocate® Lavatory System – AV-Series

Dimensions for AV-Series Advocate Lavatory Systems

Standard Height

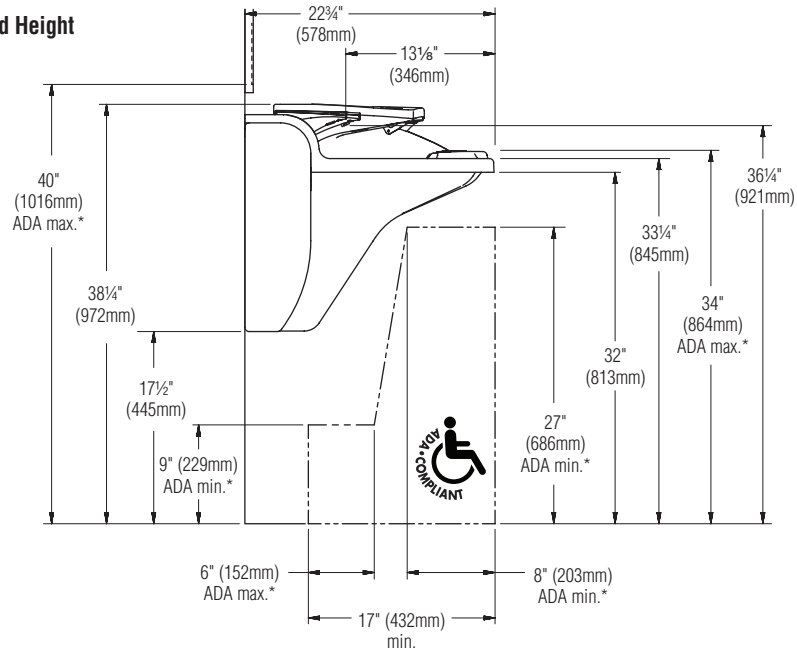

Juvenile Height

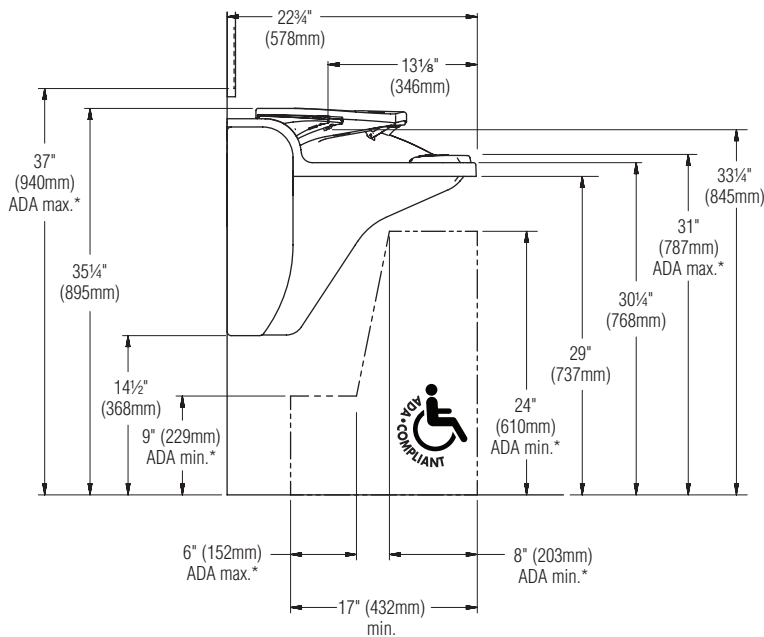

Junior Height

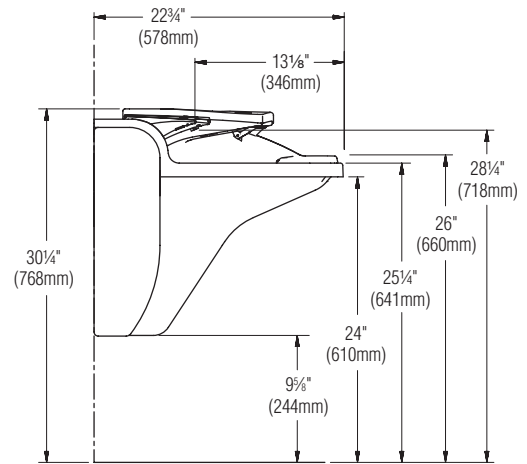

* ADA ABA Guidelines, 2004; Chapter 6: Plumbing Elements and Facilities; 606.3 Height



AV90 Advocate® Lavatory System – AV-Series

Dimensions for AV-Series Advocate Lavatory Systems

**TAS Height
Grades 6
through 8 or 9**

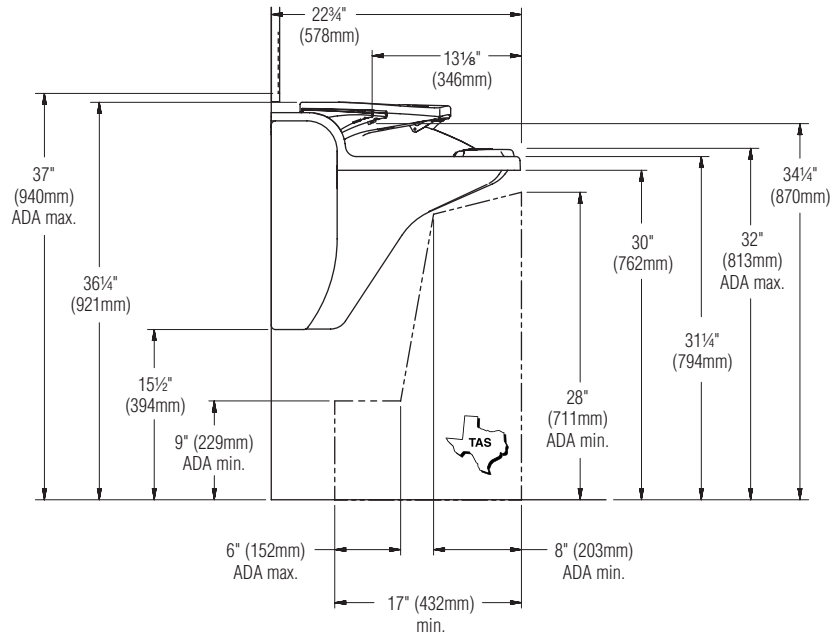

**TAS Height
Grades Pre-K
through 5 or 6**

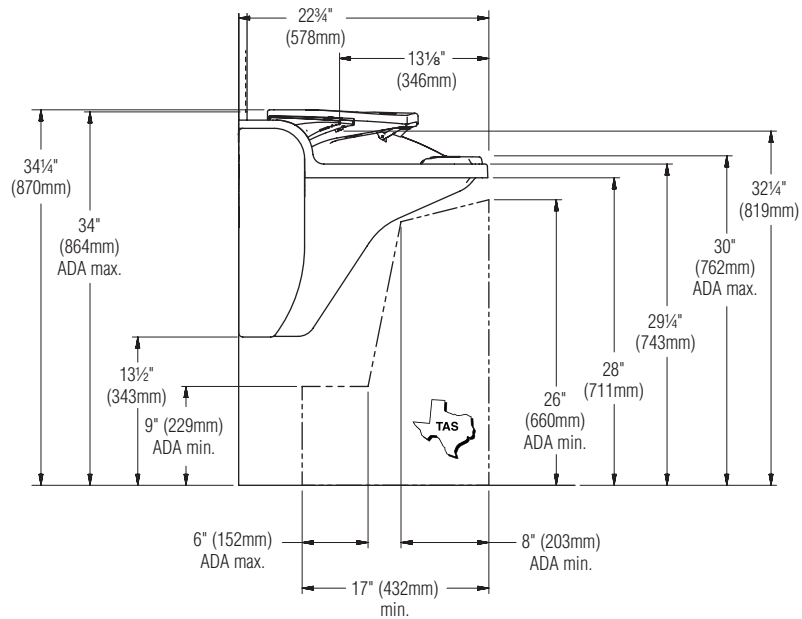



AV90 Advocate® Lavatory System – AV-Series

Rough-Ins (hot/cold, drain, electrical, and valve) for AV90 Advocate Lavatory Systems (standard height shown)

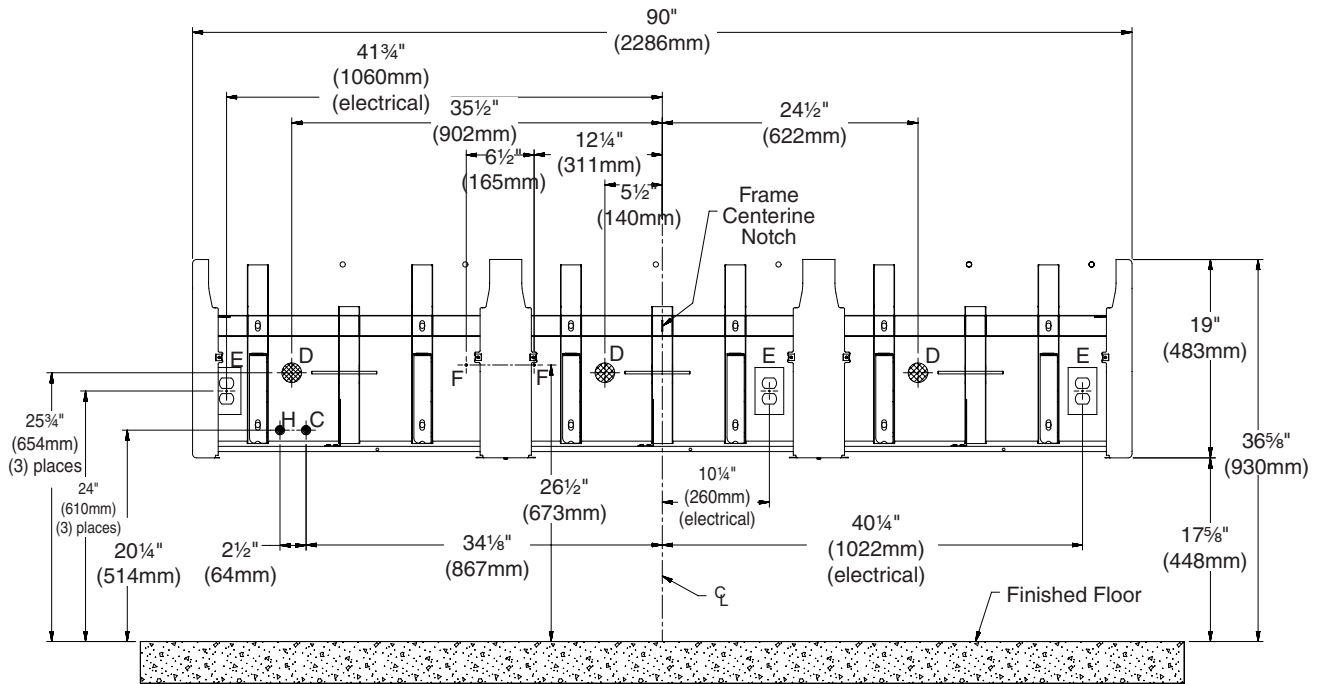

CODE	DESCRIPTION	QTY.
H, C	1/2" nominal (5/8" O.D. Comp.) Hot/Cold Supplies, Stub-Out 2" (51mm) From Wall	1
D	1 1/2" NPT Drain, Stub-Out 2" (51mm) From Wall	3
E	20-amp, 120-volt GFI Protected Electrical Outlet or 10-amp minimum circuit required for 230V (based on product selections) Circuit breaker to have a minimum instantaneous overload current rating of 6 times the circuit breaker's ampere rating.	3
F	#10 Anchors for Valve Bracket Installation	2

RIM HEIGHT	VERTICAL HEIGHT ADJUSTMENTS FOR CODES A, B, H, C, D and E	FIXTURE STYLE
34" (864mm)	No Adjustment	Standard
31" (787mm)	Subtract 3" (76mm)	Juvenile
26" (660mm)	Subtract 8" (203mm)	Junior
32" (813mm)	Subtract 2" (51mm)	TAS Grades 6 through 8 or 9
30" (762mm)	Subtract 4" (102mm)	TAS Grades Pre-K through 5 or 6



AV90 Advocate® Lavatory System – AV-Series

Backing Rough-Ins for AV90 Advocate Lavatory Systems (standard height shown)

Areas marked as require sufficient backing compliant with local building site codes. Anchor hardware is not provided.

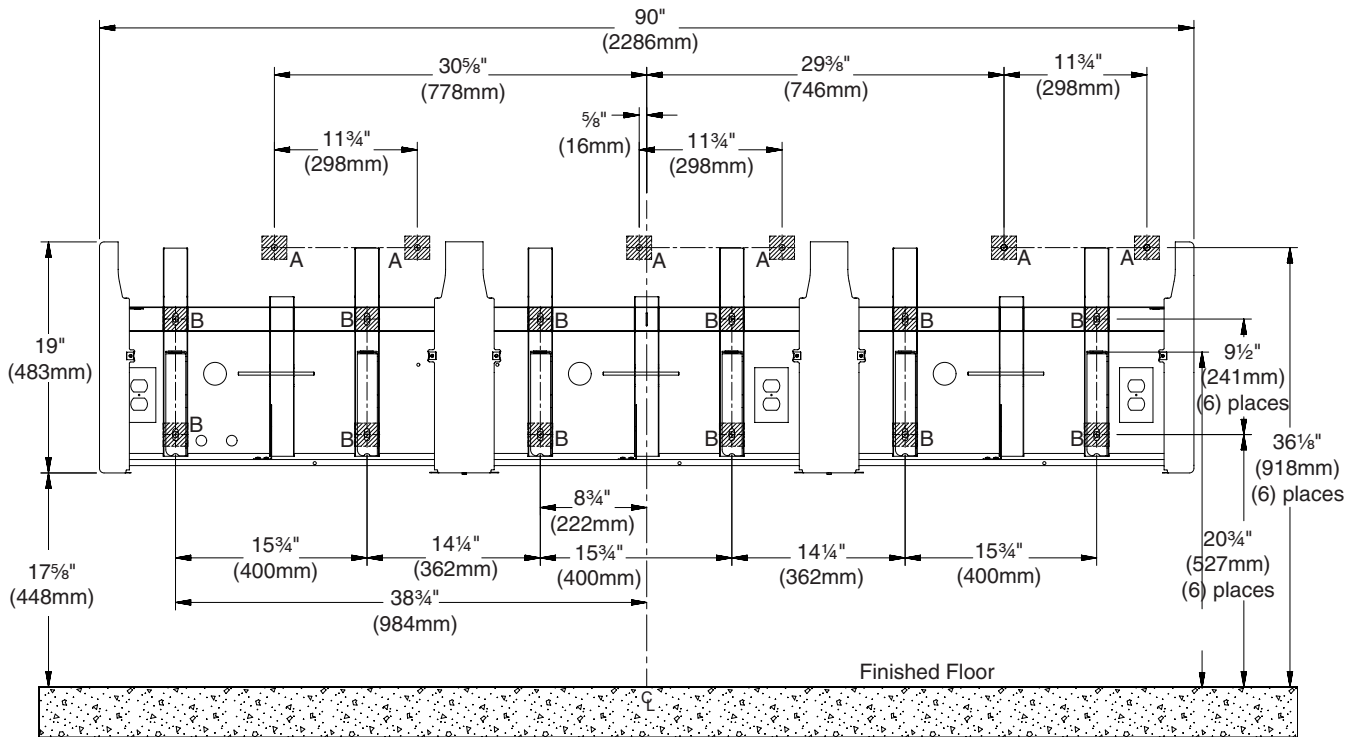

CODE	DESCRIPTION	QTY.
A	3/8" Bowl Anchors with a Minimum Pull-Out Force of 1,000 lbs.	6
B	3/8" Frame Anchors with a Minimum Pull-Out Force of 1,000 lbs.	12
RIM HEIGHT	VERTICAL HEIGHT ADJUSTMENTS FOR CODES A, B, H, C, D and E	FIXTURE STYLE
34" (864mm)	No Adjustment	Standard
31" (787mm)	Subtract 3" (76mm)	Juvenile
26" (660mm)	Subtract 8" (203mm)	Junior
32" (813mm)	Subtract 2" (51mm)	TAS Grades 6 through 8 or 9
30" (762mm)	Subtract 4" (102mm)	TAS Grades Pre-K through 5 or 6

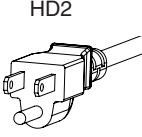
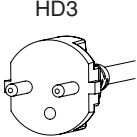
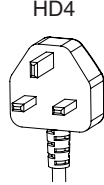

AV90 Advocate® Lavatory System – AV-Series

Model			
<input type="checkbox"/> AV90	Advocate Lavatory System – AV-Series		
Standard Selections (Must select one from each category)			
Activation Type			
<input type="checkbox"/> IRP	Faucet Spout with Adaptive Infrared		
Soap Dispenser Type			
<input type="checkbox"/> 1	Electronic Soap Dispenser		
Water Supply Type			
<input type="checkbox"/> 2	Tempered Line		
<input type="checkbox"/> 3	Navigator Thermostatic Mixing Valve		
Hand Dryer Type			
<input type="checkbox"/> HD2	Brushless DC Motor 120v/60hz, 20 Amp (Type "B")		
<input type="checkbox"/> HD3	Brushless DC Motor 230v/50hz, 10 Amp (Type "F")		
<input type="checkbox"/> HD4	Brushless DC Motor 230v/50hz, 10 Amp (Type "G")		
			
Component Finish (Faucet, Soap, Dryer)			
<input type="checkbox"/> VS	Vapor Silver		
Color of Terreon Bowl (select one):			
<i>Standard Colors</i>			
<input type="checkbox"/> CHAR	Charcoal Gray	<input type="checkbox"/> O-TAUPE	Organic Taupe
<input type="checkbox"/> COBBLE	Cobblestone	<input type="checkbox"/> PEBBLE	Pebble Beach
<input type="checkbox"/> DRIFT	Driftwood †	<input type="checkbox"/> PEP-WHT	Peppered White
<input type="checkbox"/> DUNE	Sand Dune †	<input type="checkbox"/> SAND	Sandtrap
<input type="checkbox"/> E-GRAY	Empire Gray	<input type="checkbox"/> S-CREEK	Stone Creek
<input type="checkbox"/> GRAPH	Graphite	<input type="checkbox"/> S-MIST	Silver Mist
<input type="checkbox"/> LANNON	Lannonstone	<input type="checkbox"/> WHT-SAND	White Sand
<input type="checkbox"/> LONDON	London Gray		
<input type="checkbox"/> MOONSTONE	Moonstone †		
<i>Element Colors</i>			
<input type="checkbox"/> SS-GRAY	Soapstone Gray	<input type="checkbox"/> CA-TAN	Canyon Tan
<i>Designer Colors*</i>			
<input type="checkbox"/> ARC-CHIP	Arctic Chip	<input type="checkbox"/> COFFEE	Coffee Bean
<input type="checkbox"/> RIVER	Riverstone		
<i>TerreonRE Colors*</i>			
<input type="checkbox"/> BIRCH-BARK	Birch Bark	<input type="checkbox"/> MOONDUST	Moondust
<input type="checkbox"/> DUSK	Dusk	<input type="checkbox"/> OAT	Oat
Access Panel Type			
<input type="checkbox"/> PD	High Impact Polymer, Coal		
Waste Assembly Type			
<input type="checkbox"/> D	Chrome (Single)		
<input type="checkbox"/> G	Polypropylene (Single)		

* Designer and TerreonRE colors available at an additional charge (non-cancelable, non-returnable).

† This color contains large, randomly distributed chips.