

Installation

Soap System for Express® Lavatory System MG-Series

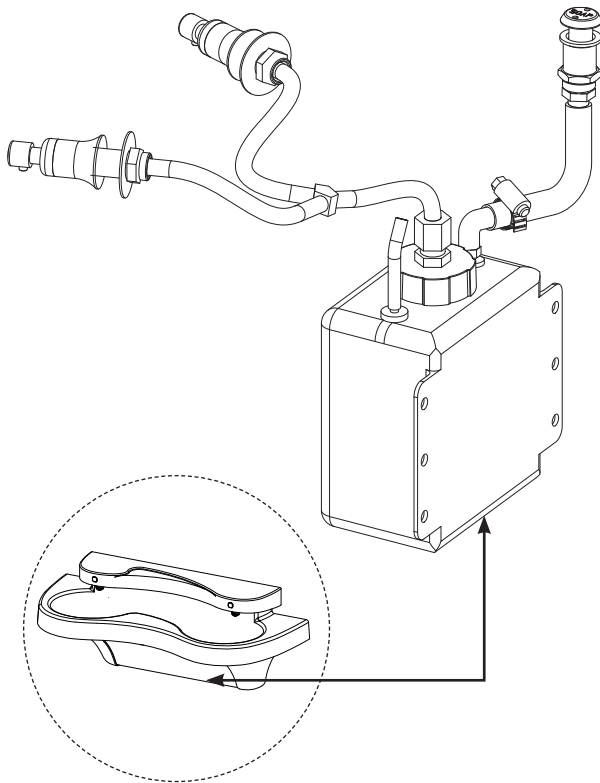
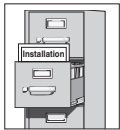

Table of Contents

Components & Repair Parts	2
Drilling Holes for No-Soap to Soap Conversion ...	3
Mounting to Frame	4
Installation	5
Soap and Valve Maintenance	6



IMPORTANT!



Read this entire installation manual to ensure proper installation. When finished with the installation, file this manual with the owner or maintenance department.



Separate parts from packaging and make sure all parts are accounted for before discarding any packaging material. If any parts are missing, do not begin installation until you obtain the missing parts.

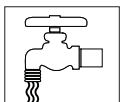

Before beginning soap tank installation, rinse out the tank with hot water to remove the packing dust. Allow the tank to air dry. Clean the soap system on a monthly basis to ensure optimum performance and maximum service life.



Product warranties may be found under “Products” on our web site at bradleycorp.com.

Components and Repair Parts

Retrofit Assembly for MG-2 Lavatory (S50-410)

Retrofit Assembly for MG-3 Lavatory (S50-411)

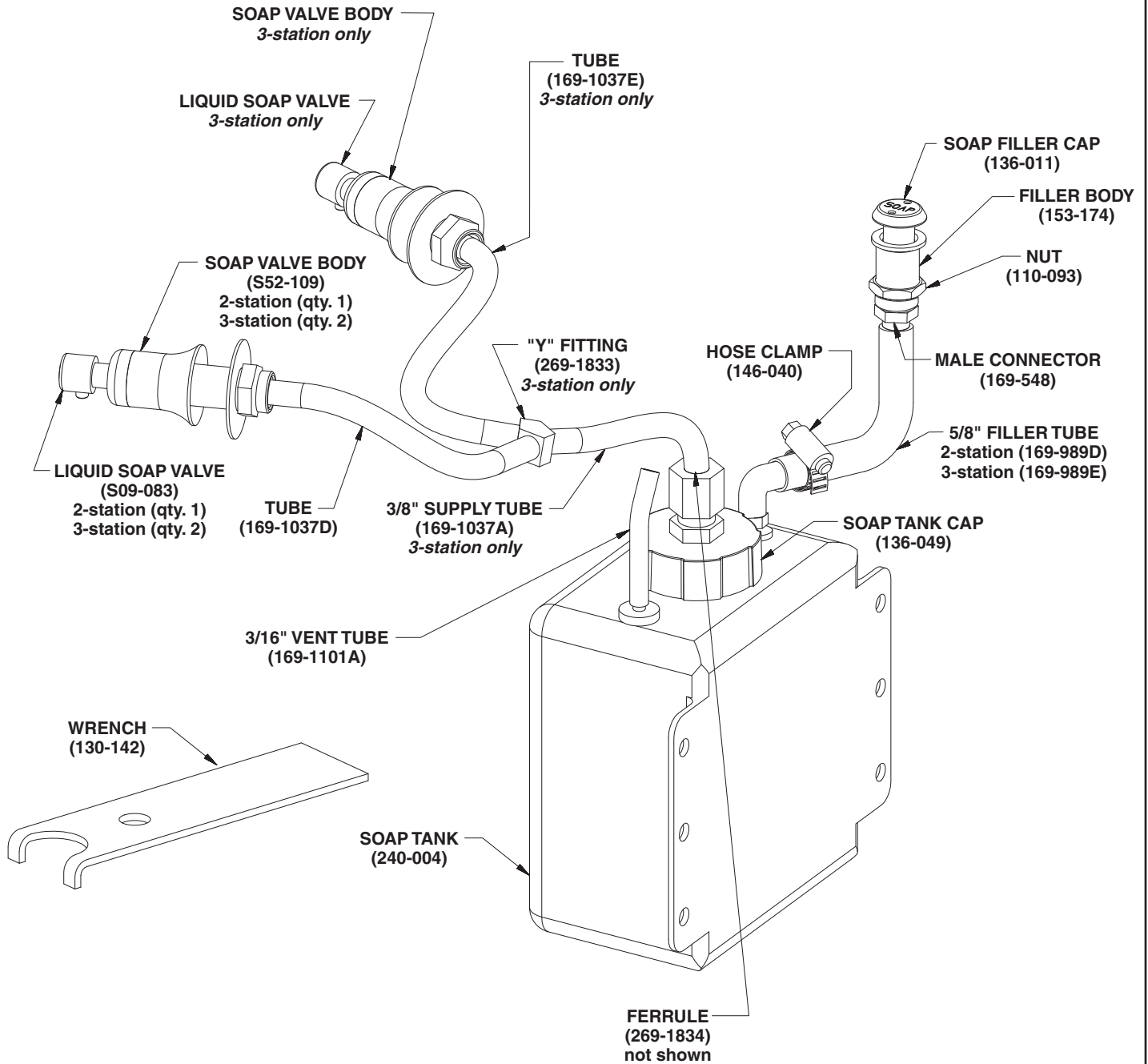

Drilling Holes for No-Soap to Soap Conversion

2-Person

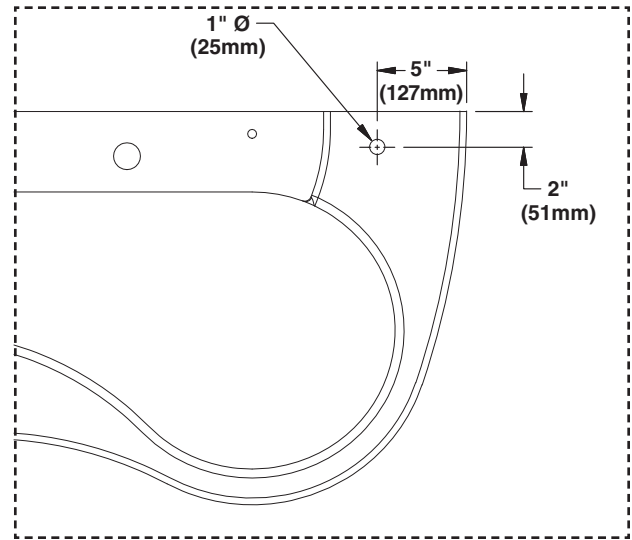

3-Person

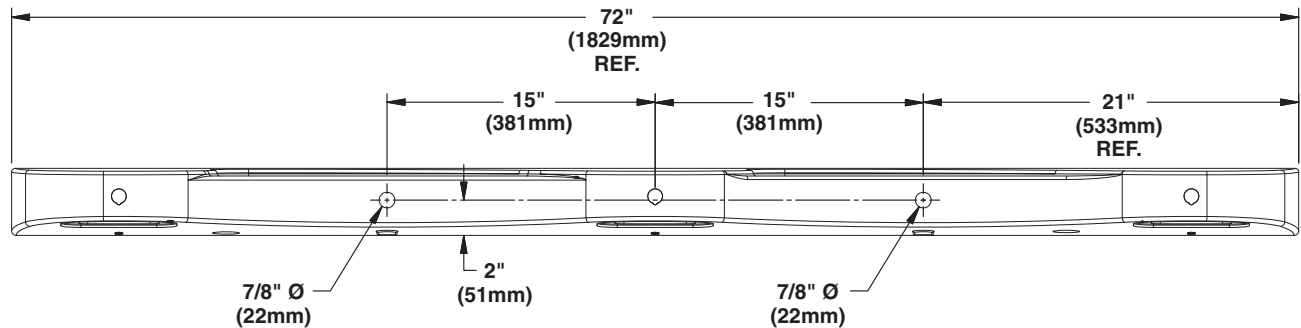
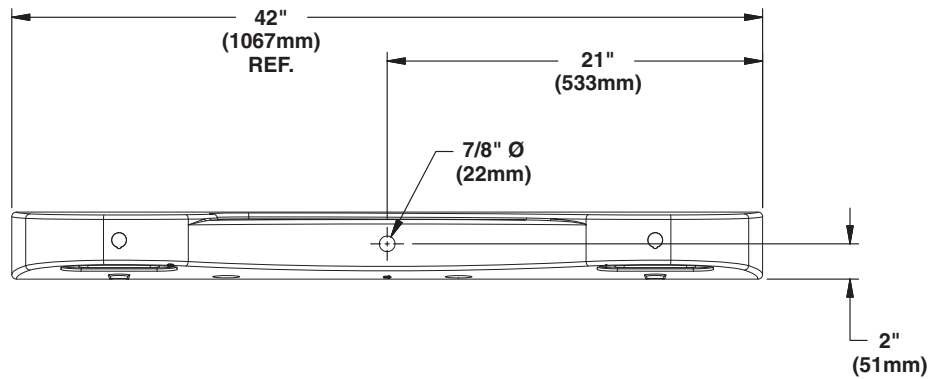

Mounting to Frame

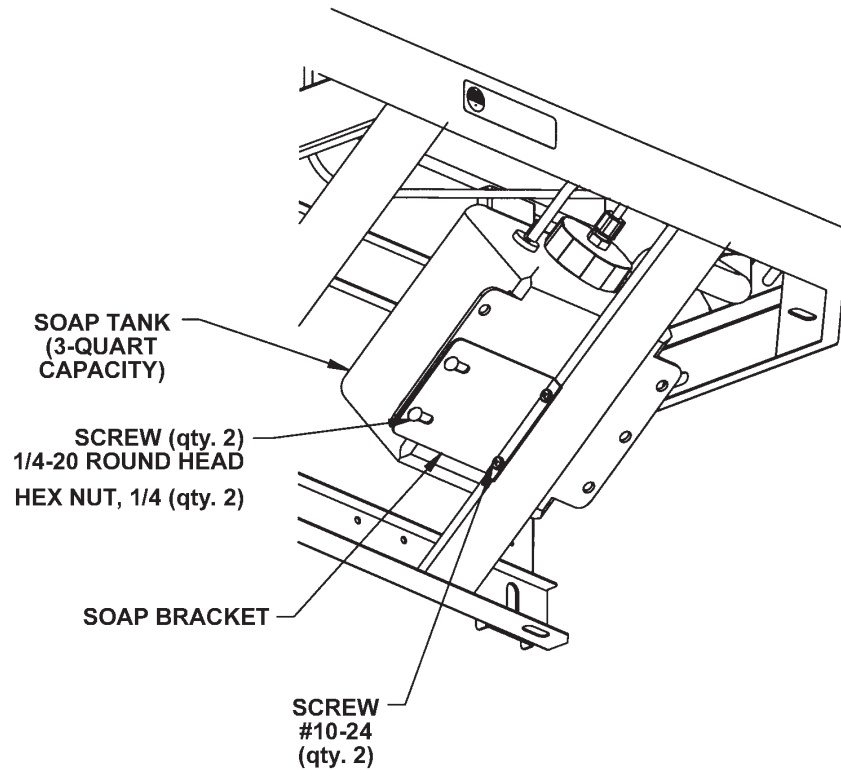
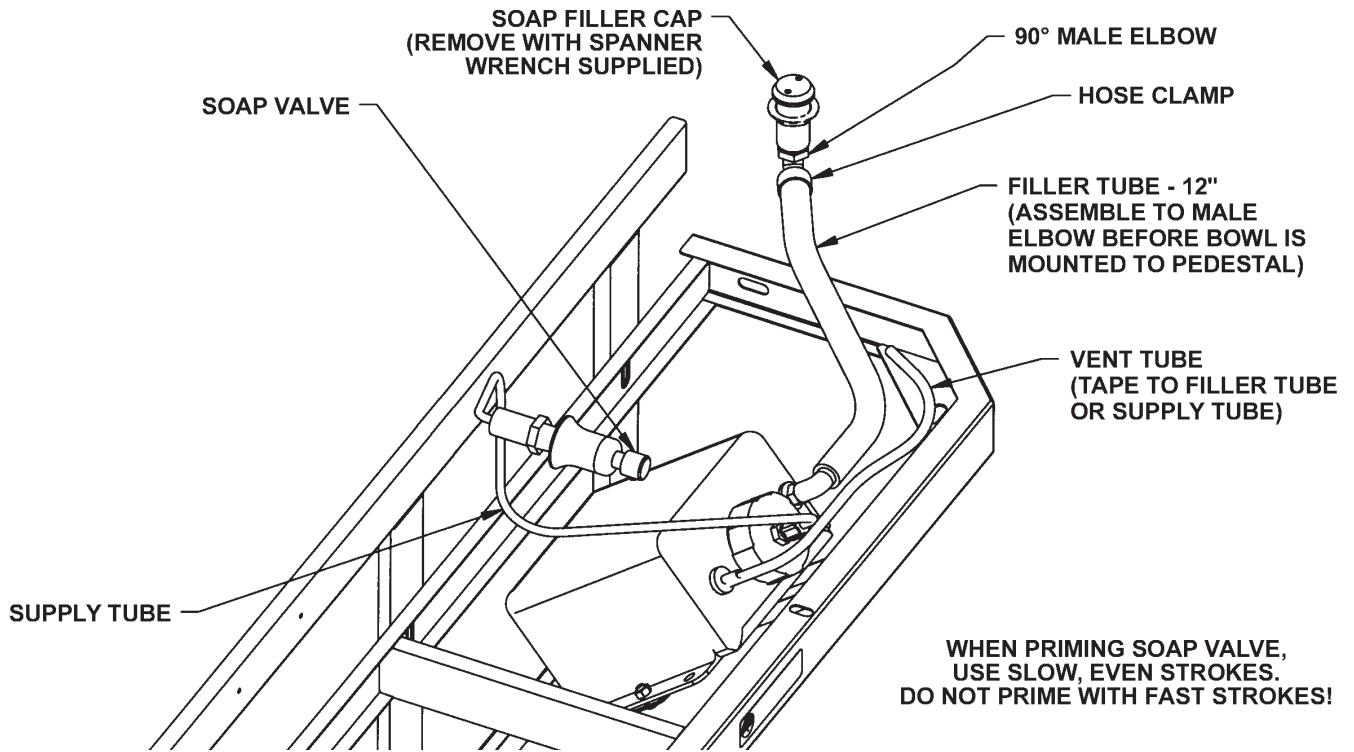

Installation

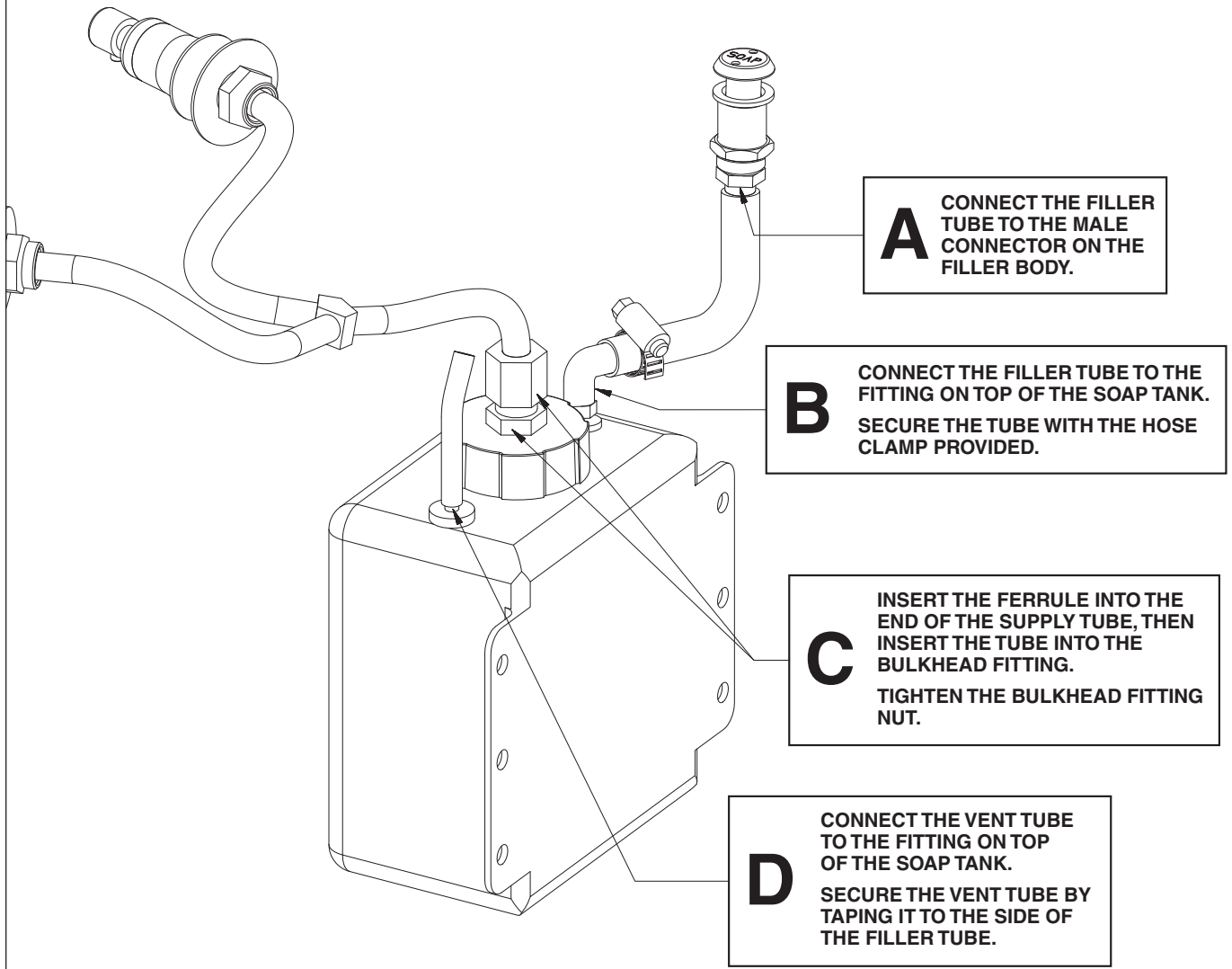

NOTE: After installation is complete, replace the access panel.
Refer to page 4 when filling the soap tank.

Soap and Valve Maintenance

A REMOVE THE FILLER CAP USING A SPANNER WRENCH.

B POUR SOAP INTO THE FILLER BODY.
 NOTE: Tank capacity is 3 quarts.
 Refer to sheet #215-1286 for Bradley
 Bradley Fixture Corporation's
 soap recommendation.

C INSTALL THE FILLER CAP AND PRIME THE SOAP VALVE(S) UNTIL SOAP IS DISPENSED.

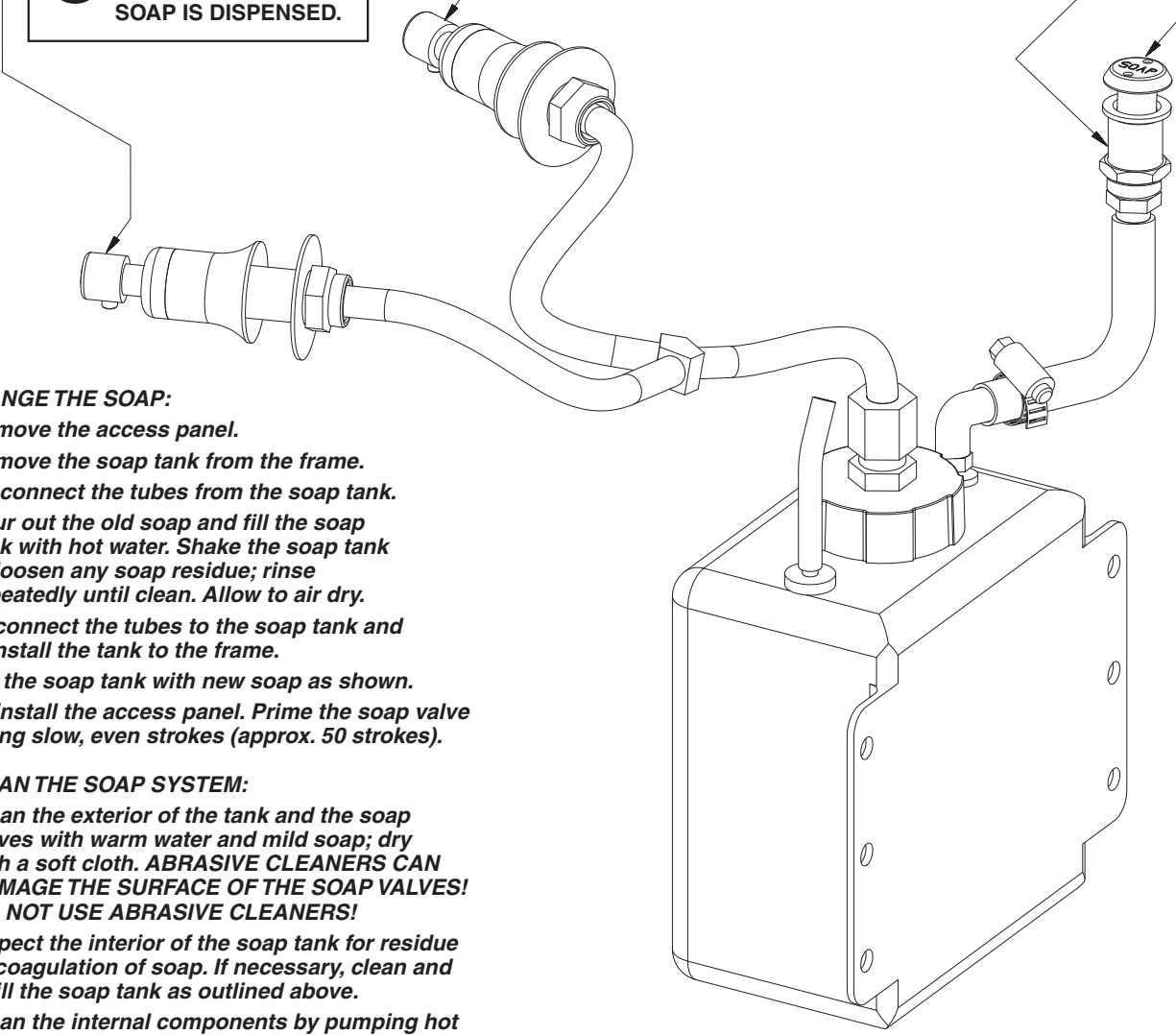

TO CHANGE THE SOAP:

1. Remove the access panel.
2. Remove the soap tank from the frame.
3. Disconnect the tubes from the soap tank.
4. Pour out the old soap and fill the soap tank with hot water. Shake the soap tank to loosen any soap residue; rinse repeatedly until clean. Allow to air dry.
5. Reconnect the tubes to the soap tank and reinstall the tank to the frame.
6. Fill the soap tank with new soap as shown.
7. Reinstall the access panel. Prime the soap valve using slow, even strokes (approx. 50 strokes).

TO CLEAN THE SOAP SYSTEM:

1. Clean the exterior of the tank and the soap valves with warm water and mild soap; dry with a soft cloth. **ABRASIVE CLEANERS CAN DAMAGE THE SURFACE OF THE SOAP VALVES! DO NOT USE ABRASIVE CLEANERS!**
2. Inspect the interior of the soap tank for residue or coagulation of soap. If necessary, clean and refill the soap tank as outlined above.
3. Clean the internal components by pumping hot water through the soap system until a clean flow of water comes out of the valve.