

Service Guide

Heat Trace Combination Drench Shower and Eyewash Unit

S19-304 Series

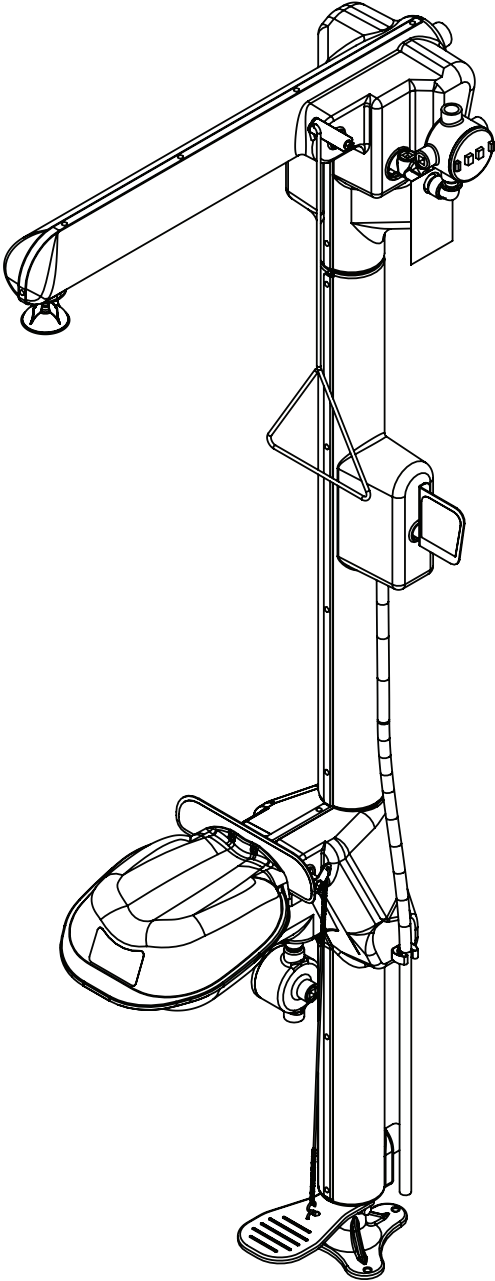

Table of Contents

Safety Information	2
Troubleshooting	3
General Service Information	4
Identifying the Unit	4
Parts Overview	5
Components (Shipped Loose)	6
Junction Box Service Parts	7
Shower Activation Service Kits	8-9
Drench Hose Activation Service Kits	10-13
Eye or Eye/Face Activation Service Kits	14-15
Body and Cap Service Kits	15
Eye and Eye/Face Wash Sprayhead Assemblies	16
Dust Covers	16
Bowl Kits	17
Anti-Scald Valve Service Kit	18
Anti-Freeze Valve Service Kit	18
Anti-Freeze and/or Anti-Scald Valve Service Instructions	19
Shell Kits	20-21
Insulation	22
Replacement Base	22
Sign Mounting Bracket	22
Replacement Rivets	22
Cleaning and Maintenance for Stainless Steel	23



Read the instructions in this manual before beginning installation. Save these instructions and refer to them for inspection, maintenance and troubleshooting information.

For questions regarding the operation, installation or maintenance of this product, visit bradleycorp.com or call 800.BRADLEY (800.272.3539).

Product warranties and parts information may also be found under “Resources” on our website at bradleycorp.com.



Safety Information

To ensure proper operation:

Installation

This fixture has been designed and 3rd party tested to meet ANSI/ISEA Z358.1. The system must be tested periodically to be sure it is functioning properly to meet the standard. Please refer to the ANSI/ISEA Z358.1 standard on testing requirements.

The installation, maintenance and location of all safety drench showers, eye and eye/face washes must comply with the requirements of ANSI/ISEA Z358.1. Workers who may come in contact with potentially hazardous materials should be trained regarding the location and proper operation of emergency equipment per ANSI/ISEA Z358.1.

ANSI/ISEA Z358.1 requires this unit to be used with a clean, potable, uninterrupted supply of tepid water. Bradley plumbed emergency fixtures require a minimum of 30 psi flowing pressure in order to function as designed and meet the ANSI/ISEA Z358.1 standard.

Before installation make sure that this equipment will meet the requirements of the potential hazardous contaminants in your location.

Installation of this system must be completed by a qualified plumber and electrician in compliance with all national and local codes. Compliance and conformity to drain requirements and other local codes and ordinances is the responsibility of the installer.

Weekly Inspections

To ensure all emergency shower and eye/face wash fixtures are ready to be used when needed, regular checks and maintenance must be conducted. Weekly inspections must be conducted on all safety equipment to make sure a suitable flushing fluid supply is present and to make sure the equipment is in good operating condition.

Water Temperature

ANSI/ISEA Z358.1 requires tepid water. Suitable range is 60°F to 100°F (16°C to 38°C). Personal injury is possible outside this temperature range.

To Avoid Product or Property Damage

Main water supply to the unit should be "ON" at all times unless system is being serviced. Provisions shall be made to prevent unauthorized shutoff.

To prevent an ice patch hazard, Bradley recommends that water discharge be directed away from the unit.

It is recommended that all water supply and electrical connections be made at temperatures above freezing. Failure to do so may result in major product and/or property damage.

Constant power supply to the safety equipment is necessary for it to function.

Avoid cleaners containing organic solvents, alcohols and hydrocarbons. Rinse with potable water after cleaning.

Troubleshooting

Problem	Cause	Solution
Low water flow at drench shower and eyewash	Insufficient pressure Undersized supply piping	Minimum 30 GPM required Increase pressure/pipe size
Low water flow at drench shower or eye wash	Debris in system	Disassemble the showerhead, clean and reassemble Unscrew the eyewash heads from the yoke, clean and reassemble. If still clogged, replace the heads.
Anti-freeze valve is flowing water	Power supply is off [if the water temperature from the valve is below 40°F (4°C)]	Turn the power on.
	Water supply is too cold	Make sure the unit is supplied with tempered water.
	Defective thermostat [if the water temperature from the valve is below 40°F (4°C)]	Check continuity and replace if check fails activates at 50°F (10°C) (factory-set).
	Defective anti-freeze valve [if the water temperature from the valve is above 40°F (4°C)]	Replace the anti-freeze valve NOTE: A water supply that is at least 40°F (4°C) or colder will hold the freeze bleed valve open. To close the valve: <ol style="list-style-type: none"> turn the water off temporarily or plug the valve until the heat trace unit's heat warms the valve increase the surface temperature of the valve to above 40°F (4°C) by immersing the valve in hot water IMPORTANT: Make sure that the heat trace unit is operating properly before plugging the freeze bleed valve. A plugged valve will not provide backup freeze protection should the heat trace unit fail.
Anti-scald valve is flowing water	Defective anti-scald valve [if the water temperature from the valve is below 80°F (27°C)]	Replace the anti-scald valve.
	Direct sunlight or high ambient temperature	Cool the unit.
	Defective thermostat	Check continuity and replace if check fails activates at 50°F (10°C) (factory-set).

General Service Information

⚠ WARNING Follow all manufacturer's installation guides when troubleshooting components in the unit.

NOTICE! Anti-scald valve and drench hose options cannot be retrofitted onto existing unit.

NOTICE! Heating cable is not available for service.

NOTICE! Indicator lights used on S19-300 series units are not compatible with S19-304 series units.

NOTICE! If replacing components that have heat trace cable applied to them, the components and heating cable must be restored to the original position. Use fiberglass tape provided to securely re-attach heating cable to plumbing.



Indicator light parts breakdown available in indicator light installation manuals (215-1860, 215-1861, 215-1862).



To access any internal components, remove the rivets and then remove shell. To replace any misplaced rivets, order service kit S65-439. This kit includes 15 new rivets.



If work needs to be done under the insulation, carefully cut the insulation, taking care not to damage the heating cable. If insulation is damaged beyond use, insulation is available for service. Customer will have to cut to fit. Super heavy duty tape (supplied by installer) will be required to tape the insulation back together.



Phantom parts shown in breakdowns for reference only.

Identifying the Unit

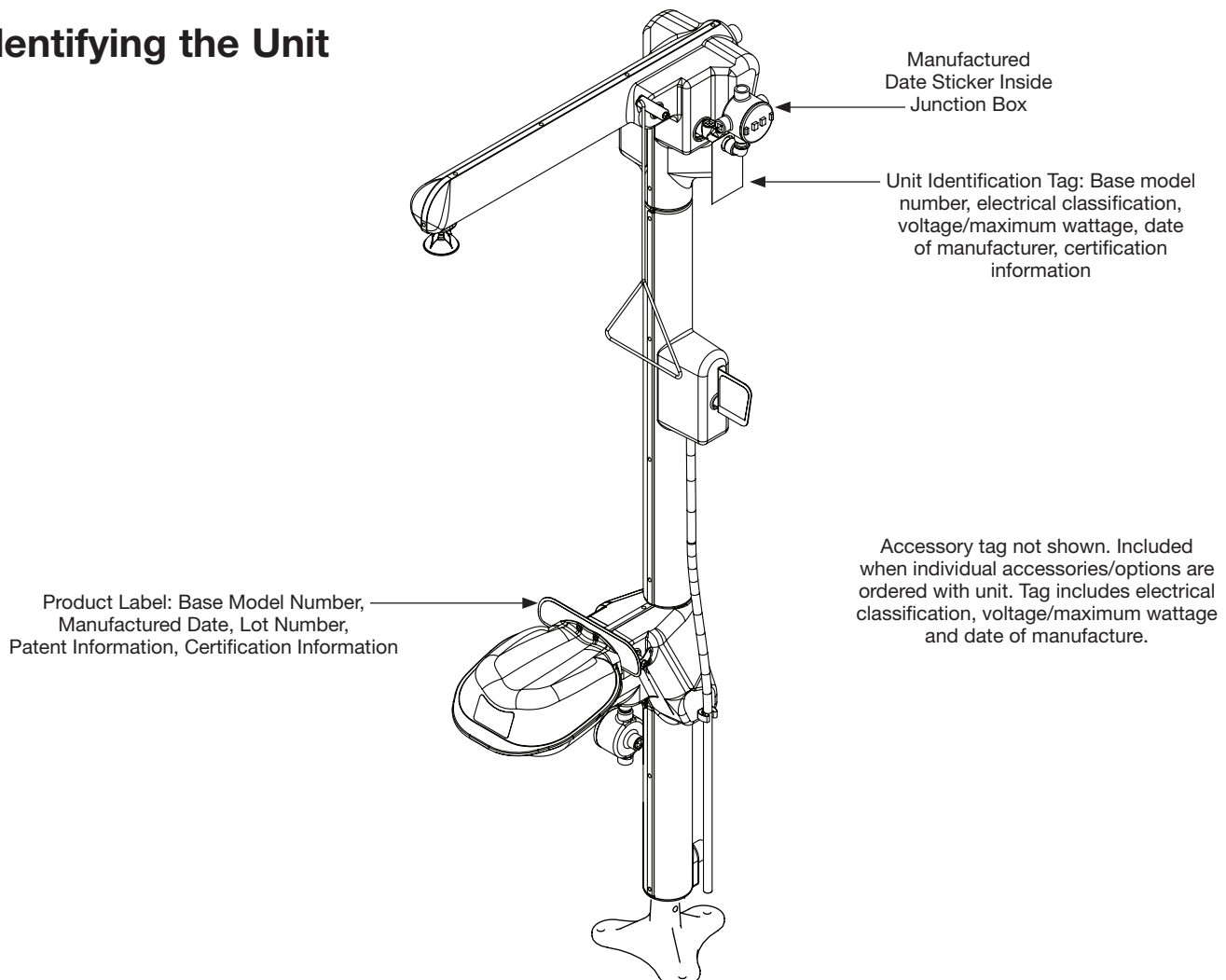

Parts Overview

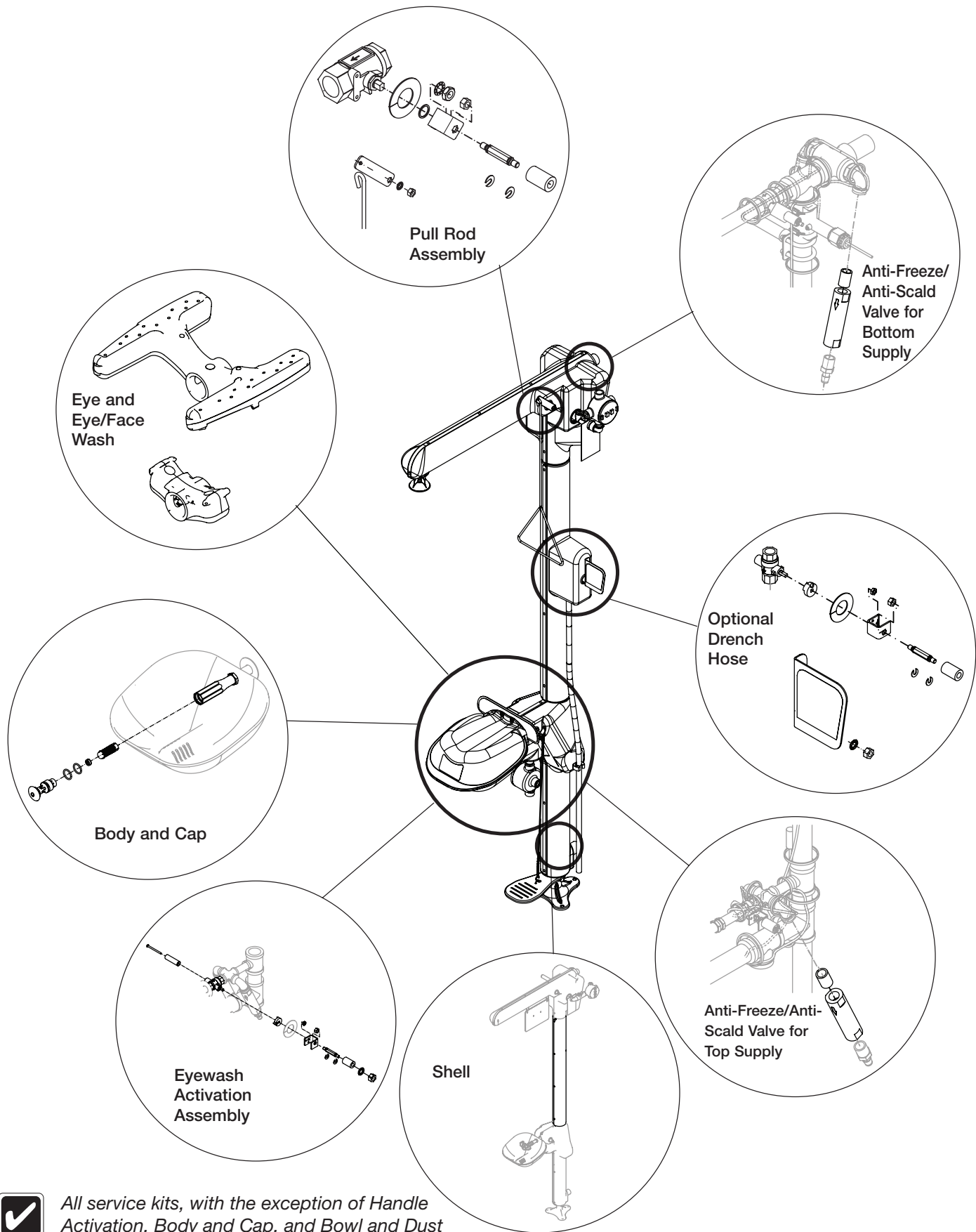

All service kits, with the exception of Handle Activation, Body and Cap, and Bowl and Dust Cover Kits, will require removal of shell and insulation.

Components (Shipped Loose)

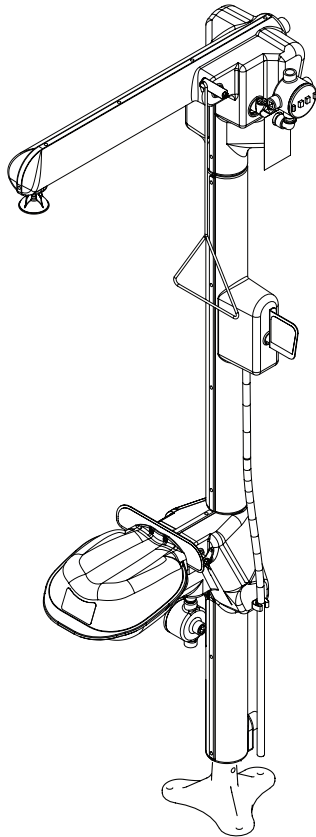

Heat Trace Unit
S19-304T (top supply)
S19-304B (bottom supply)

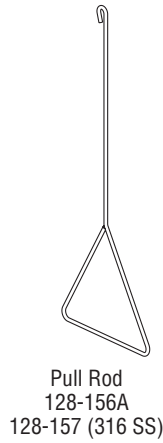

Pull Rod
128-156A
128-157 (316 SS)

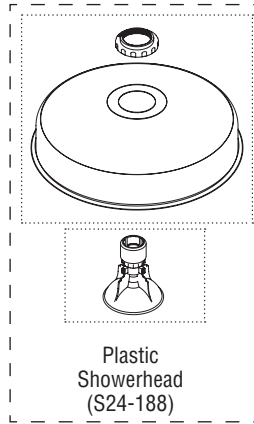

Plastic Showerhead (S24-188)

Plastic Shroud and Ring (S24-192)
Stainless Steel Shroud and Ring (S24-193)

Optional Shower Shroud and Retaining Nut

304 Stainless Steel Showerhead (S24-191)
316 Stainless Steel Showerhead (S24-201)

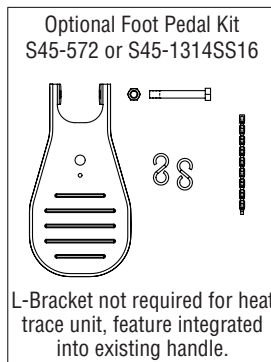

Optional Foot Pedal Kit
S45-572 or S45-1314SS16

L-Bracket not required for heat trace unit, feature integrated into existing handle.

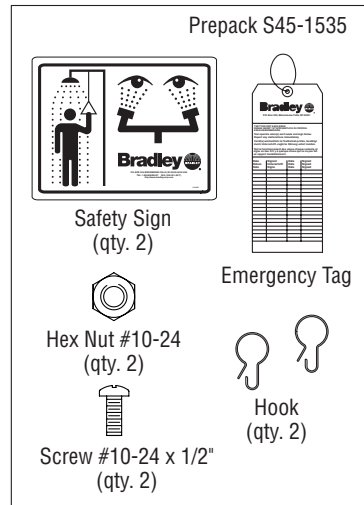

Prepack S45-1535



Safety Sign (qty. 2)

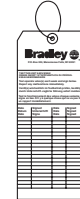

Emergency Tag



Hex Nut #10-24 (qty. 2)



Screw #10-24 x 1/2" (qty. 2)



Hook (qty. 2)

Junction Box Service Parts

⚠ WARNING Power supplied to the unit should be 120VAC or 208-240VAC, 50-60 Hz, 15 amp branch circuit with a dedicated circuit breaker or fuse and should not supply power to any other device. Compliance and conformity to local codes and ordinances is the responsibility of the installer.

⚠ WARNING When making electrical connections be sure to follow all lockout-tagout safety procedures.

Notice! To ensure the integrity of the junction box, all installer supplied cable glands and connections must be maintained to appropriate standards.



Reference the unit's installation manual for schematic information.

General Area

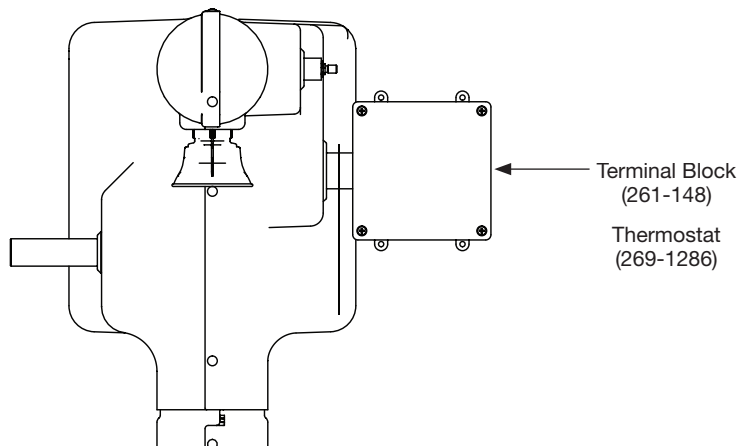

Class 1 Division 2 and Class 2 Division 1 and 2

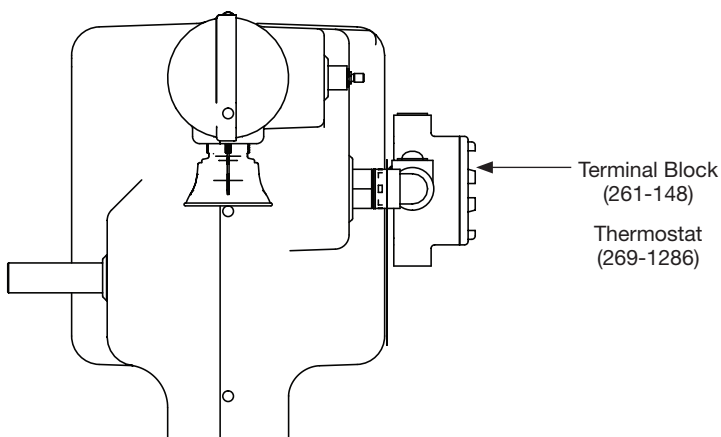

Class 1 Division 1

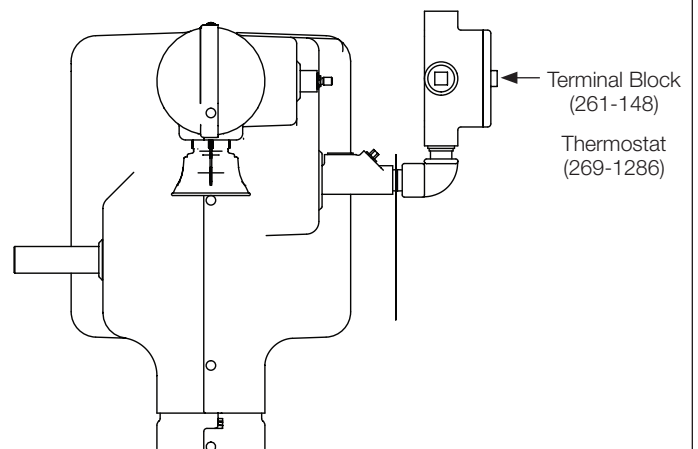

S65-470 (Galvanized) - Shower Activation Service Kit with Ball Valve

Item	Qty	Description
326	1	1" Ball Valve - Frost Proof
327	1	Washer .609x.750x.048
328	1	Adapter Ball Valve
329	1	Handle Adapter
330	1	Nut 5/16-18 hex
331	1	Operating Stem
332	2	Clip - Retaining
333	1	Sleeve
440	1	Handle
442	1	Lock Washer
443	1	Nut 5/16/18
361	1	Fiberglass Tape - 1/2" Wide 60 ft* Roll
381	1	Cable Tie*

*Not Shown

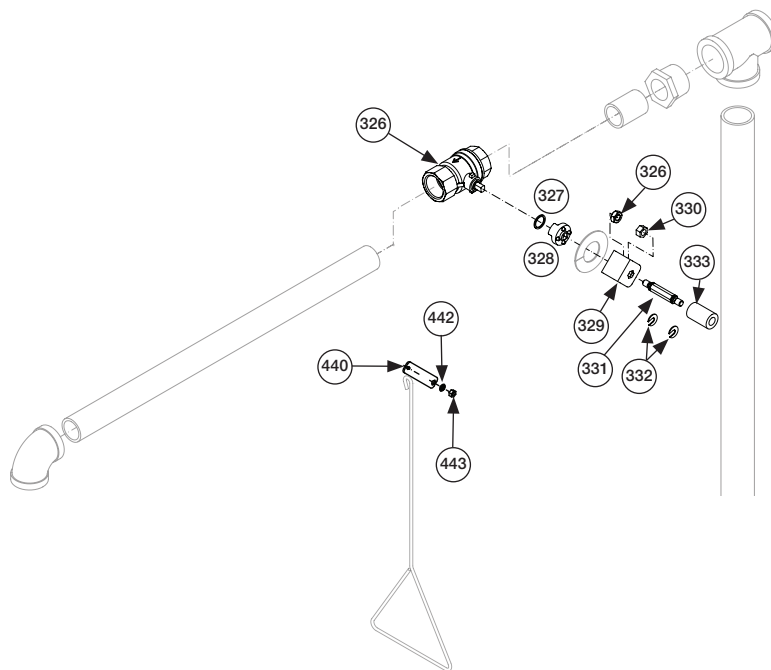

S65-471 (304SS) & S65-472 (316SS) - Shower Activation Service Kit with Ball Valve

Item	Qty	Description
326	1	1" Ball Valve - Frost Proof
327	1	Washer .609x.750x.048
328	1	Adapter Ball Valve
329	1	Handle Adapter
330	1	Nut 5/16-18 hex
331	1	Operating Stem
332	2	Clip - Retaining
333	1	Sleeve
440	1	Handle
442	1	Lock Washer
443	1	Nut 5/16/18
361	1	Fiberglass Tape - 1/2" Wide 60 ft* Roll
381	1	Cable Tie*

*Not Shown

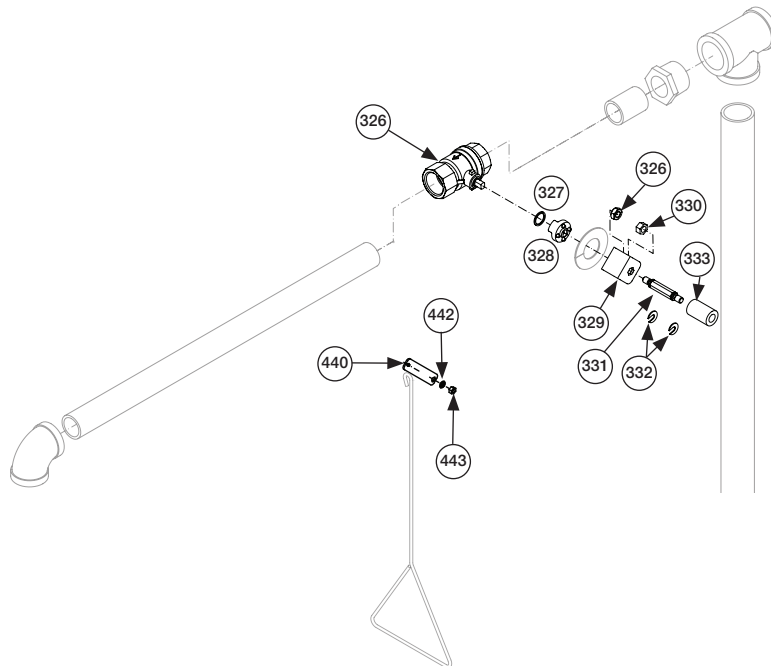

S65-467 (Galvanized) - Shower Activation Service Kit

Item	Qty	Description
327	1	Washer .609x.750x.048
328	1	Adapter Ball Valve
329	1	Handle Adapter
330	1	Nut 5/16-18 hex
331	1	Operating Stem
332	2	Clip - Retaining
333	1	Sleeve
440	1	Handle
442	1	Lock Washer
443	1	Nut 5/16/18
361	1	Fiberglass Tape - 1/2" Wide 60 ft* Roll
381	1	Cable Tie*

*Not Shown

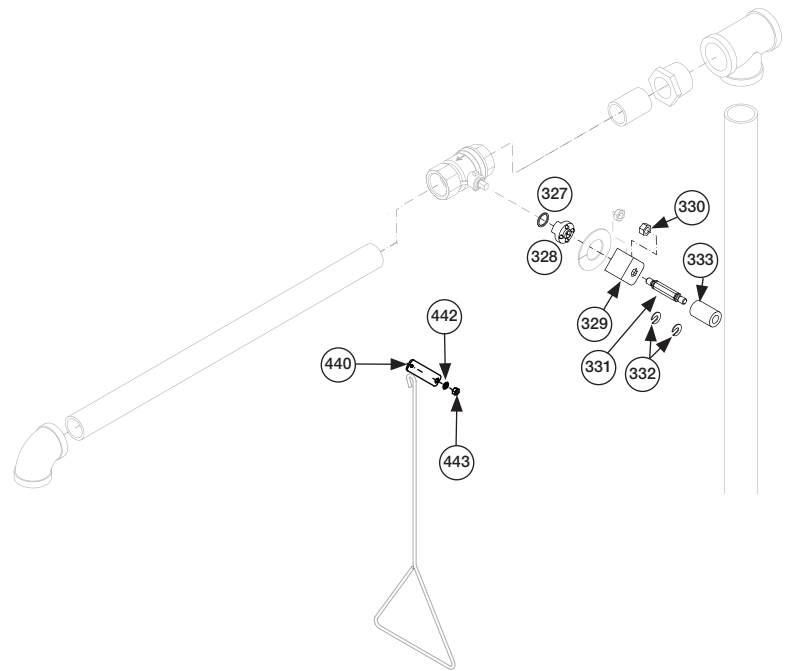

S65-468 (304SS) & S65-469 (316SS) - Shower Activation Service Kit

Item	Qty	Description
327	1	Washer .609x.750x.048
328	1	Adapter Ball Valve
329	1	Handle Adapter
330	1	Nut 5/16-18 hex
331	1	Operating Stem
332	2	Clip - Retaining
333	1	Sleeve
440	1	Handle
442	1	Lock Washer
443	1	Nut 5/16/18
361	1	Fiberglass Tape - 1/2" Wide 60 ft* Roll
381	1	Cable Tie*

*Not Shown

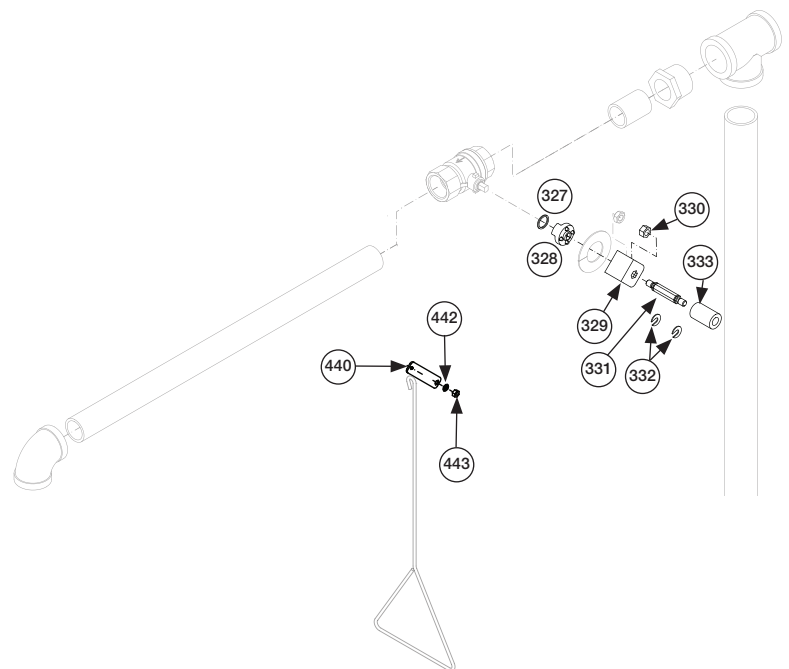

S21-068 - Stem Kit (Galvanized, 304SS and 316SS)

Item	Qty	Description
331	1	Operating Stem
332	2	Clip - Retaining
333	1	Sleeve

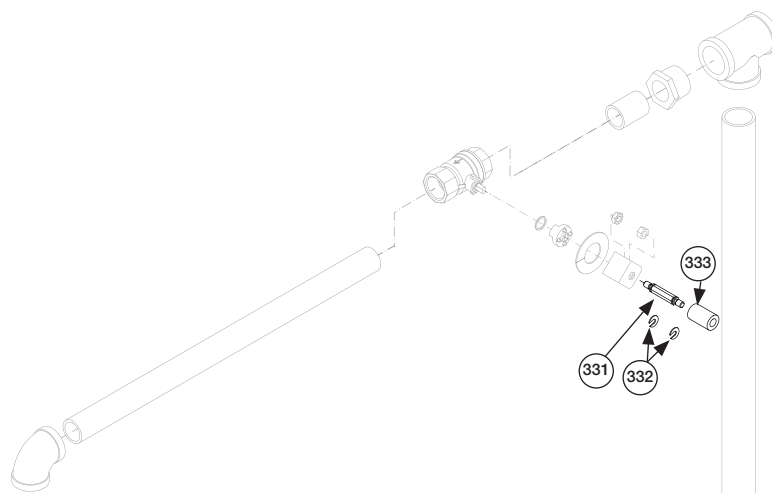

S65-464 (Galvanized) - Drench Hose Activation Service Kit with Ball Valve

Item	Qty	Description
306	1	Ball Valve, 1/2" Brass Frost-Proof
307	1	Ball Valve Adapter, RH
308	1	Washer
309	1	Handle Adapter, 304SS
310	1	Operating Stem
311	1	Nut, 5/18-18 Hex
313	2	Clip - Retaining
314	1	Sleeve
435	1	Flag Handle Assembly
436	1	Washer, 5/16 int-tooth
437	1	Nut 5/16 -18 hex
361	1	Fiberglass Tape - 1/2" Wide 60 ft* Roll
381	1	Cable Tie*

*Not Shown

Replacement yellow hose tube is part number S89-025 (cut to length to ensure 1" gap from flood plane).

Retaining clip hardware for hose tube is 132-042.

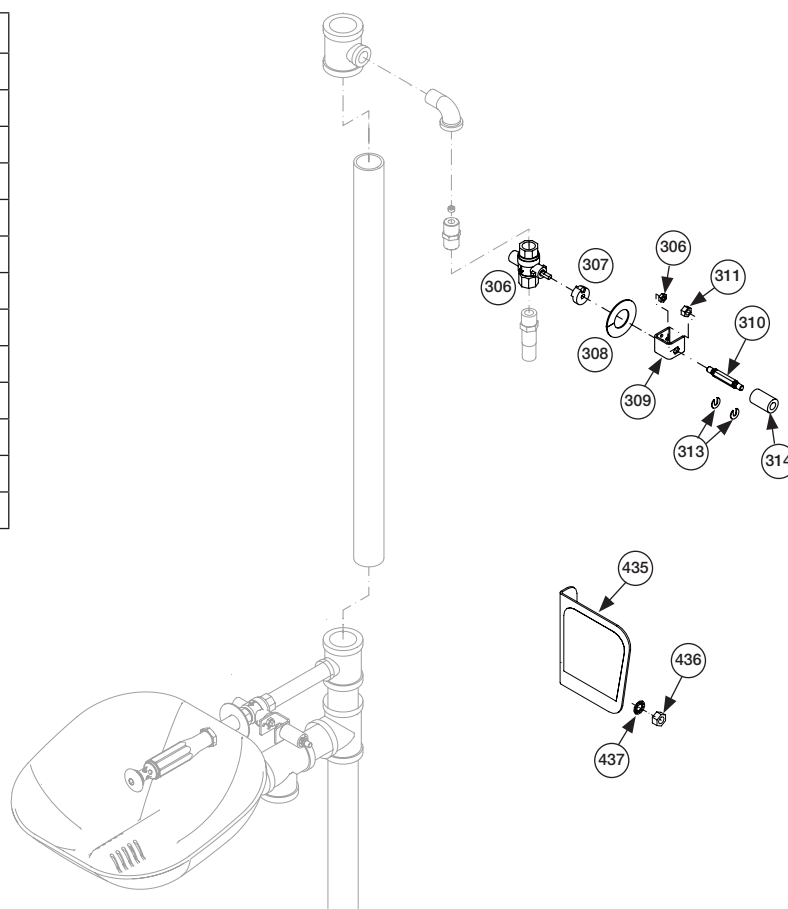

S65-465 (304SS) & S65-466 (316SS) - Drench Hose Activation Service Kit with Ball Valve

Item	Qty	Description
306	1	Ball Valve, 1/2" SS Frost-Proof
307	1	Ball Valve Adapter, RH
307	1	Ball Valve Adapter, RH, 316SS
308	1	Washer
309	1	Handle Adapter, 304SS
309	1	Handle Adapter, 316SS
310	1	Operating Stem
310	1	Operating Stem, 316SS
311	1	Nut, 5/16-18 Hex
311	1	Nut, 5/16-18 Hex, 316SS
313	2	Clip - Retaining
314	1	Sleeve
435	1	Flag Handle Assembly, 316SS
436	1	Washer, 5/16 int-tooth
437	1	Nut 5/16-18 hex
437	1	Nut 5/16-18 hex, 316SS
361	1	Fiberglass Tape - 1/2" Wide 60 ft*
381	1	Cable Tie*

*Not Shown

Replacement yellow hose tube is part number S89-025 (cut to length to ensure 1" gap from flood plane).

Retaining clip hardware for hose tube is 132-042.

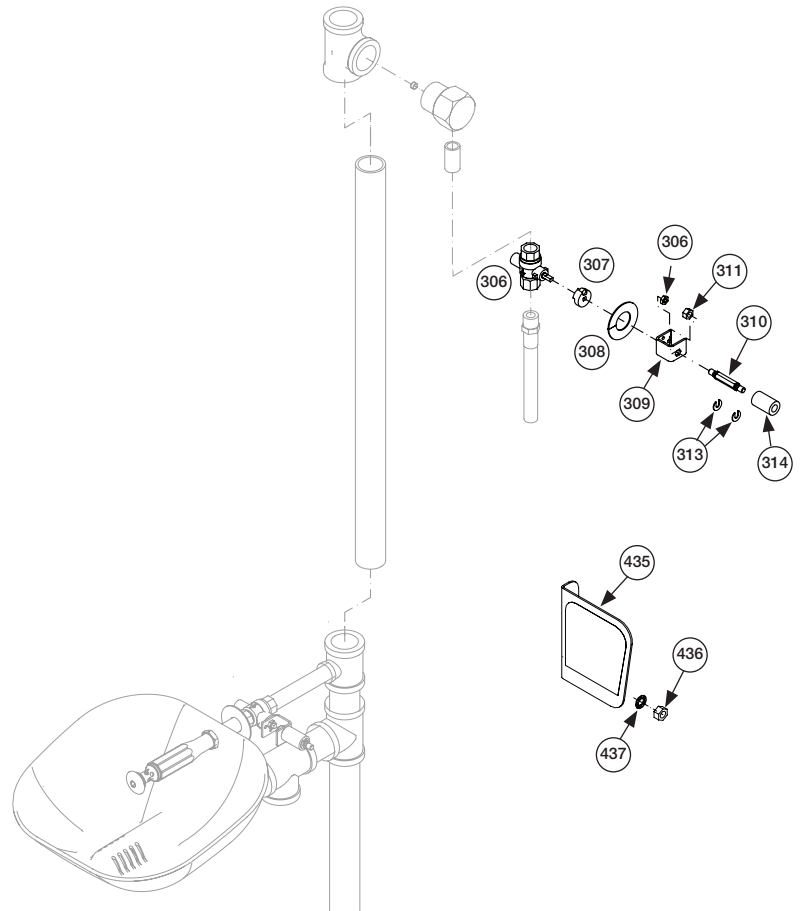

S65-462 (Galvanized and 304SS) - Drench Hose Activation Service Kit

Item	Qty	Description
307	1	Ball Valve Adapter, RH
308	1	Washer
309	1	Handle Adapter, 304SS
310	1	Operating Stem
311	1	Nut, 5/18-18 Hex
313	2	Clip - Retaining
314	1	Sleeve
435	1	Flag Handle Assembly
436	1	Washer, 5/16 int-tooth
437	1	Nut 5/16 -18 hex
361	1	Fiberglass Tape - 1/2" Wide 60 ft* Tape Roll
381	1	Cable Tie*

*Not Shown

Replacement yellow hose tube is part number S89-025 (cut to length to ensure 1" gap from flood plane).

Retaining clip hardware for hose tube is 132-042.

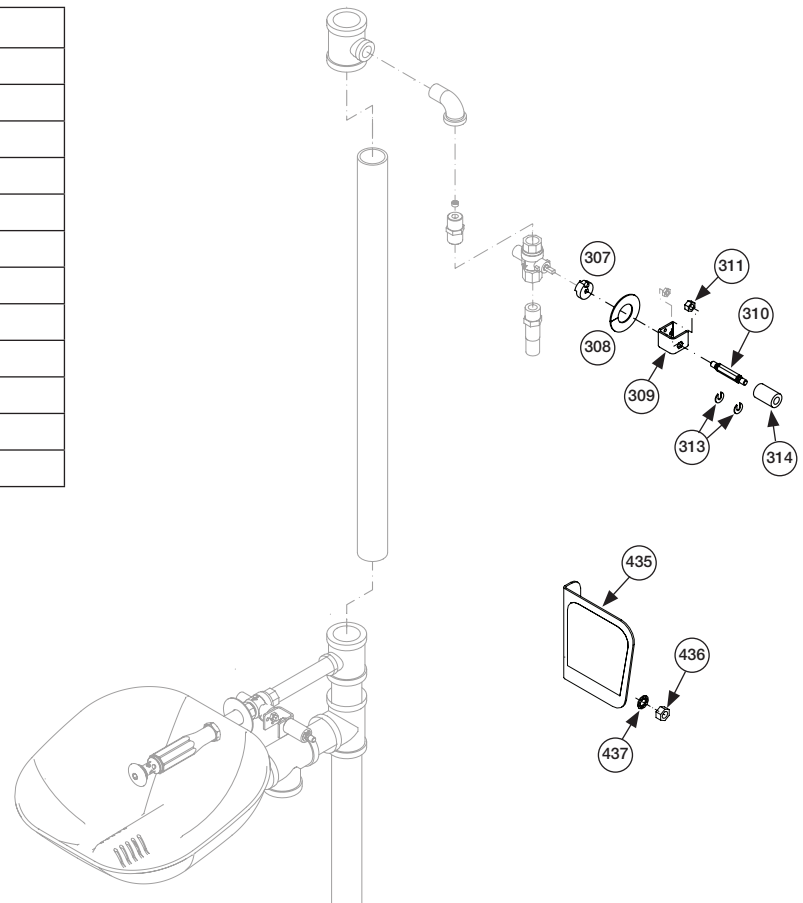

S65-463 (316SS) - Drench Hose Activation Service Kit

Item	Qty	Description
307	1	Ball Valve Adapter, RH 316SS
308	1	Washer
309	1	Handle Adapter, 316SS
310	1	Operating Stem, 316SS
311	1	Nut, 5/18-18 Hex, 316SS
313	2	Clip - Retaining
314	1	Sleeve
435	1	Flag Handle Assembly, 316SS
436	1	Washer, 5/16 int-tooth
437	1	Nut 5/16 -18 hex, 316SS
361	1	Fiberglass Tape - 1/2" Wide 60 ft* Roll
381	1	Cable Tie*

*Not Shown

Replacement yellow hose tube is part number S89-025 (cut to length to ensure 1" gap from flood plane).

Retaining clip hardware for hose tube is 132-042.

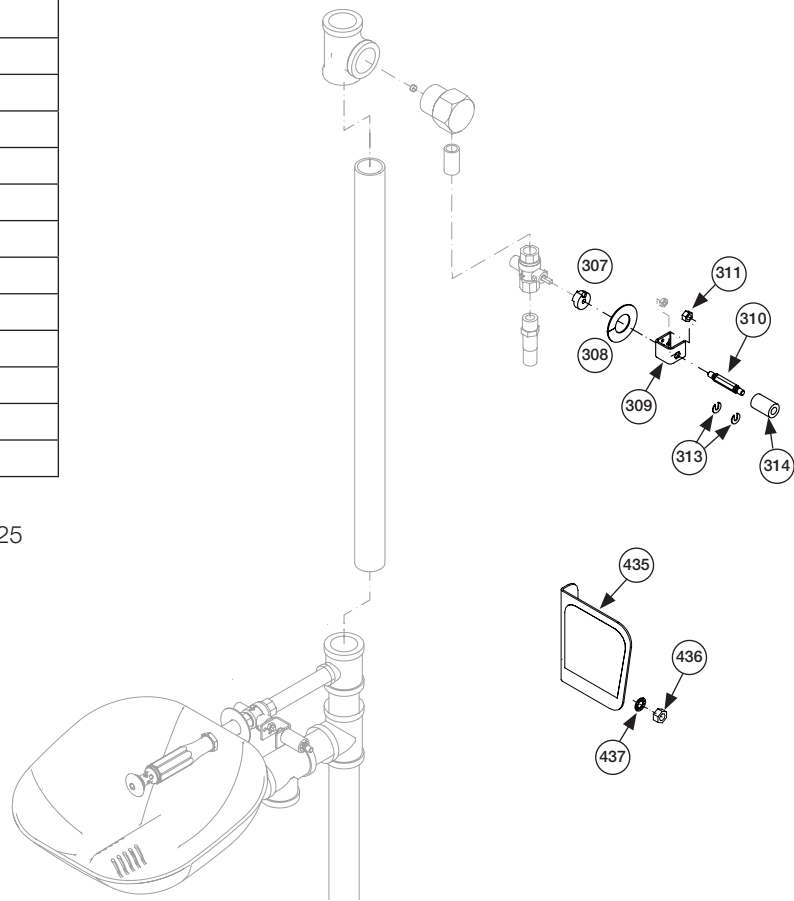

Drench Hose Service Instructions

1. Remove the rivets from the mid-shell pieces so the shell can be pulled away from the unit (or removed completely). Other components may have to be disassembled to remove the shell.
2. Expose the drench hose handle components by partially removing the insulation.
3. Connect the drench hose parts as shown using pipe sealant on the threads. Do not secure the flag handle permanently at this time.
4. Operate the valve to ensure parts are installed correctly before reattaching the shell. The flag handle must operate in the same fashion as the eyewash handle.
5. Re-route the hose through the existing hole.
6. Install the new grommet for shaft seal.
7. Reattach the shell with rivets.
8. Tighten the retaining nut on the flag handle.
9. Install the clip with screw to restrain the hose.

S65-459 (Galvanized), S65-460 (304SS) and S65-461 (316SS) - Eye or Eye/Face Activation Service Kit with Ball Valve

Item	Qty	Description
6	1	Ball Valve, Chrome Brass, Frost-Proof
6	1	Ball Valve, 304SS, Frost-Proof
6	1	Ball Valve, 316SS, Frost-Proof
35	1	Ball Valve Adapter, RH
35	1	Ball Valve Adapter, RH, SS316
36	1	Handle Adapter, 304SS
32	1	Sleeve
37	1	Nut 5/16-18 hex
38	1	Operating Stem
38	1	Operating Stem, 316SS
39	2	Clip, Retaining
445	1	Spacer
446	1	Screw, 1/4-20 x 3/-1/4
446	1	Screw, 1/4-20 x 3-1/4, 316SS
447	1	Lock Washer
448	1	Nut
448	1	Nut, 316SS
449	1	Eye or Eye/Face Activation Handle
449	1	Eye or Eye/Face Activation Handle, 316SS
361	1	Fiberglass Tape - 1/2" Wide 60 ft*Roll
381	1	Cable Tie*

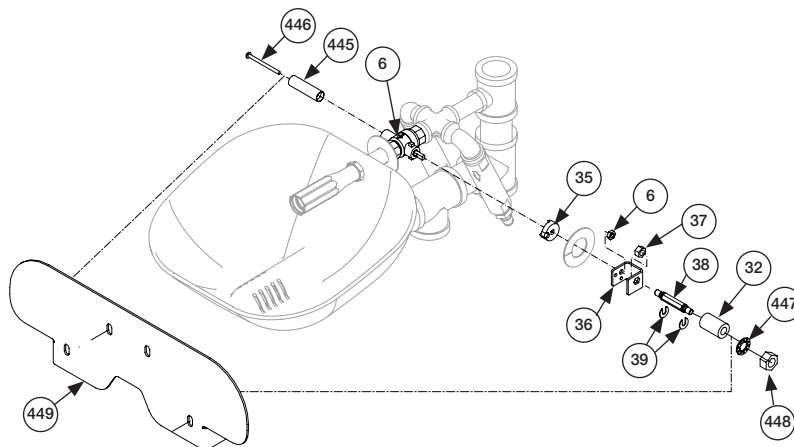

*Not Shown

S65-457 (Galvanized & 304SS) and S65-458 (316SS) - Eye or Eye/Face Activation Handle

Item	Qty	Description
449	1	Handle
449	1	Handle, 316SS
450	1	Label

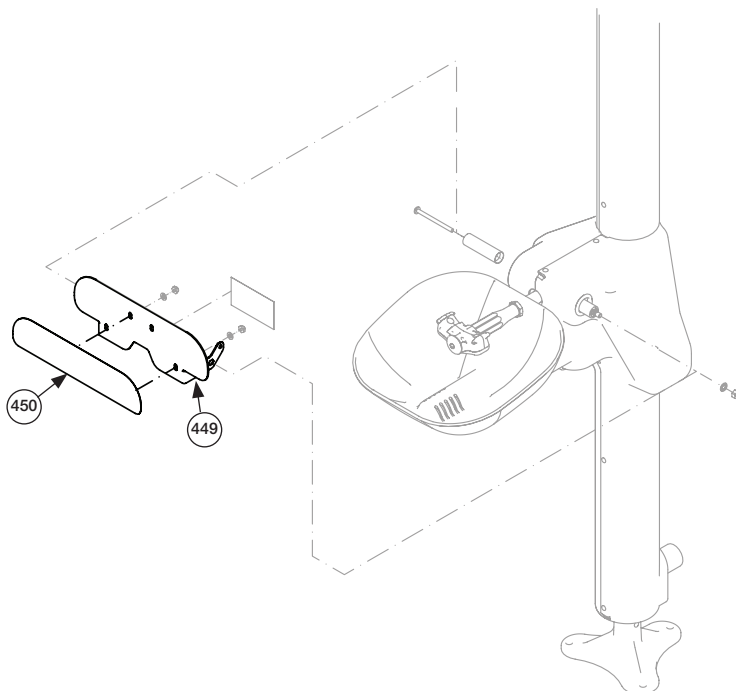

S65-455 (Galvanized/304SS) and S65-456 (316SS) - Eye or Eye/Face Activation Service Kit

Item	Qty	Description
35	1	Ball Valve Adapter, RH
35	1	Ball Valve Adapter, RH, 316SS
36	1	Handle Adapter
36	1	Handle Adapter, 316SS
32	1	Sleeve
37	1	Nut 5/16-18 hex
37	1	Nut 5/16-18 hex, 316SS
38	1	Operating Stem
38	1	Operating Stem, 316SS
39	2	Clip, Retaining
445	1	Spacer
446	1	Screw, 1/4-20 x 3-1/4
446	1	Screw, 1/4-20 x 3-1/4, 316SS
447	1	Lock Washer
448	1	Nut
448	1	Nut, 316SS
449	1	Eye or Eye/Face Activation Handle
449	1	Eye or Eye/Face Activation Handle, 316SS
361	1	Fiberglass Tape - 1/2" Wide 60 ft* Roll
381	1	Cable Tie*

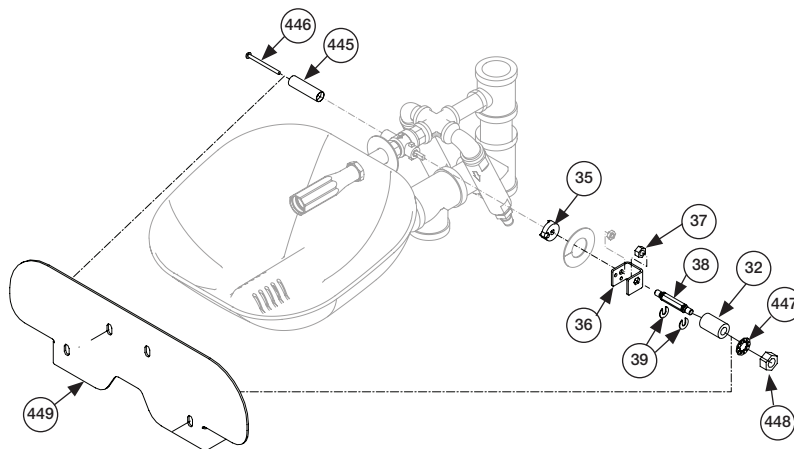

*Not Shown

S65-452 (Galvanized), S65-453 (304SS) and S65-454 (316SS) - Body and Cap Service Kits

Item	Qty	Description
40	1	Cap, Anodized Aluminum
40	1	Cap, 304SS
40	1	Cap, 316SS
41	2	O-Ring
42	1	Flow Control
43	1	Strainer
29	1	Body Mount, Anodized Aluminum
29	1	Body Mount, 304SS
29	1	Body Mount, 316SS

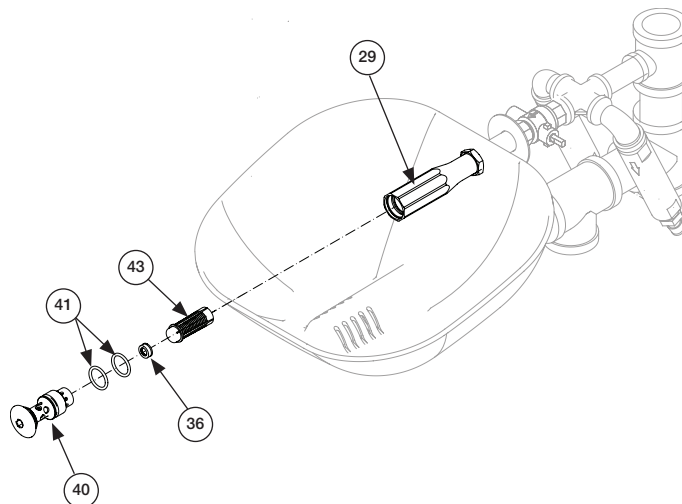

NOTICE! Aluminum body mount is not compatible with stainless steel eye/face wash.

Eye and Eye/Face Wash Sprayhead Assemblies



Replacement sprayhead assemblies come with flip dust covers. These can be removed because S19-304 units have bowl dust cover to protect sprayhead.

Plastic Eye/Face Wash (S05-192)
 316SS Eye/Face Wash (S05-205)

Note: 304SS Eye/Face Wash (S05-204) replaced with 316SS Eye/Face Wash (S05-205).

Plastic Eyewash (S05-190)

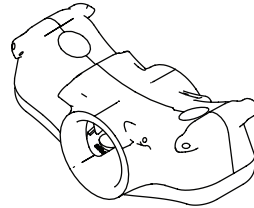
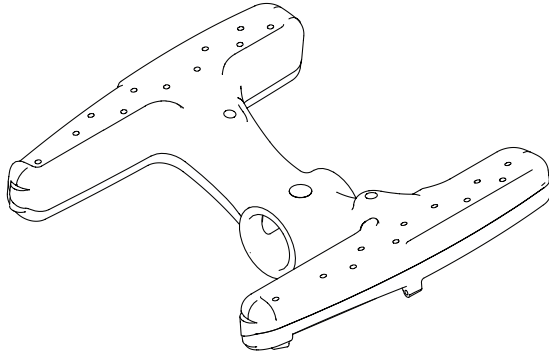

S90-390 (Plastic), S90-388 (304SS) and S90-389 (316SS) Dust Covers



All bowl dust covers are required for this system. All cover materials fit all bowl type materials.

Plastic Bowl Cover Prepack (S90-390)

304 Stainless Steel Bowl Cover Prepack (S90-388)
 316 Stainless Steel Bowl Cover Prepack (S90-389)

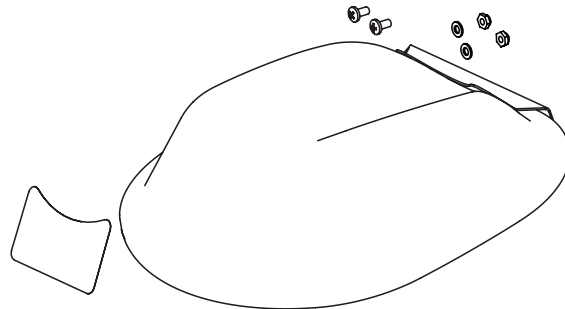
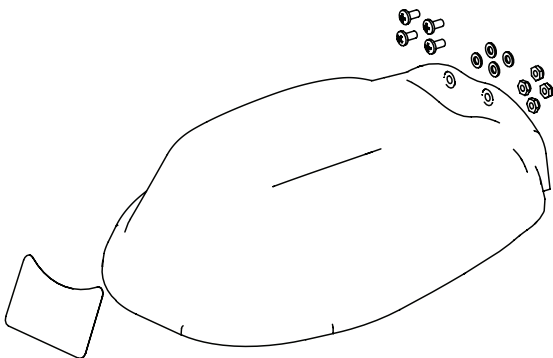

S65-449 (SS to Galvanized), S65-450 (304SS to 304SS) and S65-451 (316SS to 316SS) - Bowl Kit with Stainless Steel Bowl

Item	Qty	Description
20	1	Nut, 2 NPSM SS
21	1	O-Ring
22	1	Bowl Mount, Painted
22	1	Bowl Mount, 304SS
22	1	Bowl Mount, 316SS
23	1	Gasket
24	4	Screw, 1/4-20 x 3/4" SS
24	4	Screw, 1/4-20 x 3/4" 316SS
25	1	Bowl, SS
25	1	Bowl, 316SS
28	2	Nut, 1/2-14 Hex, SS
28	2	Nut, 1/2-14 Hex, SS
28	2	Nut, 1/2-14 Hex, 316SS

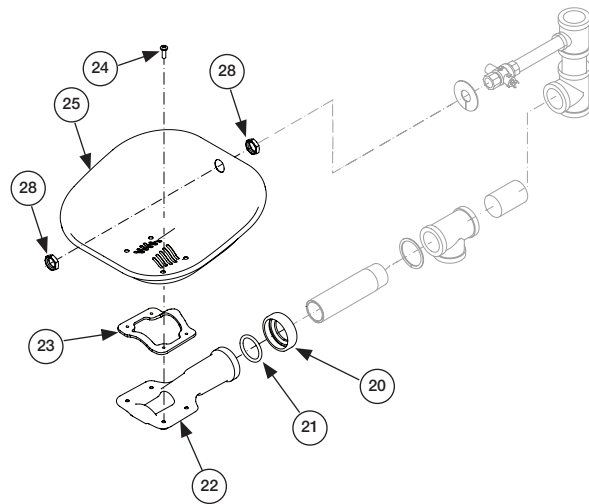

S65-448 - Bowl Kit with Plastic Bowl

Item	Qty	Description
28	2	Nut, 1/2-14 Hex
20	1	Nut 2 NPSM
21	1	O-Ring
25	1	Bowl, Plastic

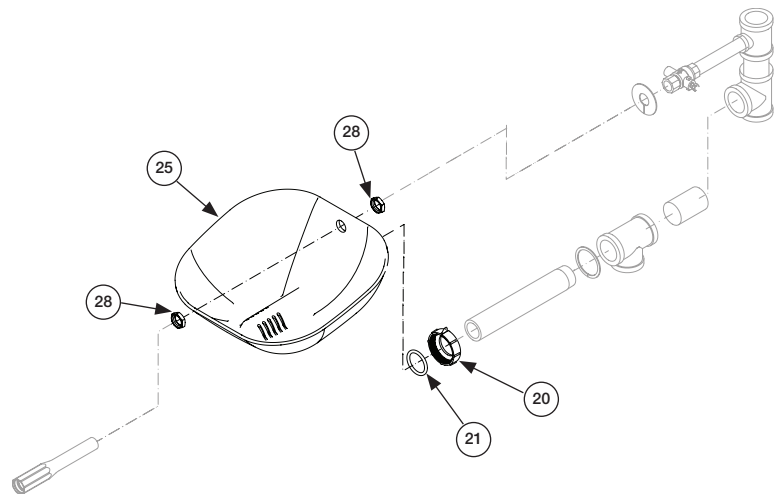

S65-445 (Galvanized/304SS) and S65-447 (316SS) - Anti-Scald Valve Service Kit

Item	Qty	Description
10	1	Anti-Scald Valve
10	1	Anti-Scald Valve, 316SS
8	1	Pipe, 1/2 x Close, 304SS
8	1	Pipe, 1/2 x Close, 316SS
361	1	Fiberglass Tape - 1/2" Wide 60 ft* Roll
381	1	Cable Tie*

*Not Shown

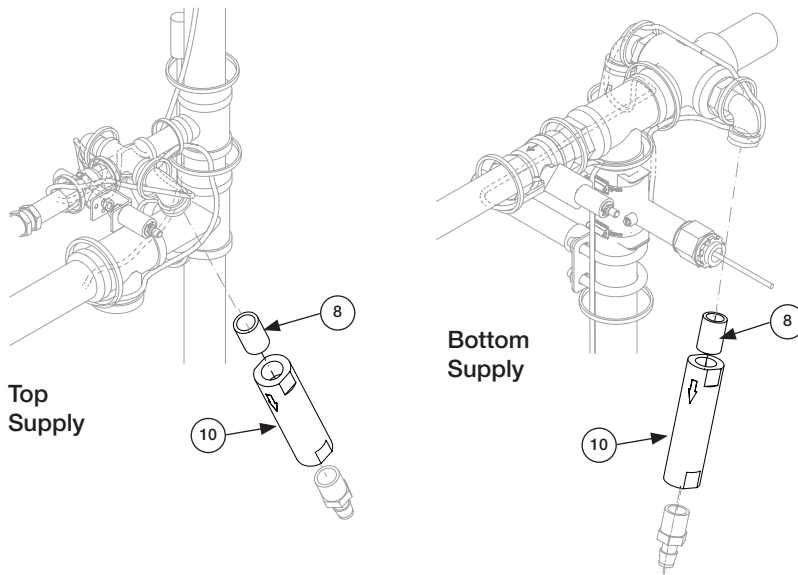

S65-444 (Galvanized/304SS) and S65-446 (316SS) - Anti-Freeze Valve Service Kit

Item	Qty	Description
10	1	Anti-Freeze Valve
10	1	Anti-Freeze Valve, 316SS
8	1	Pipe, 1/2 x Close, 304SS
8	1	Pipe, 1/2 x Close, 316SS
361	1	Fiberglass Tape - 1/2" Wide 60 ft* Roll
381	1	Cable Tie*

*Not Shown

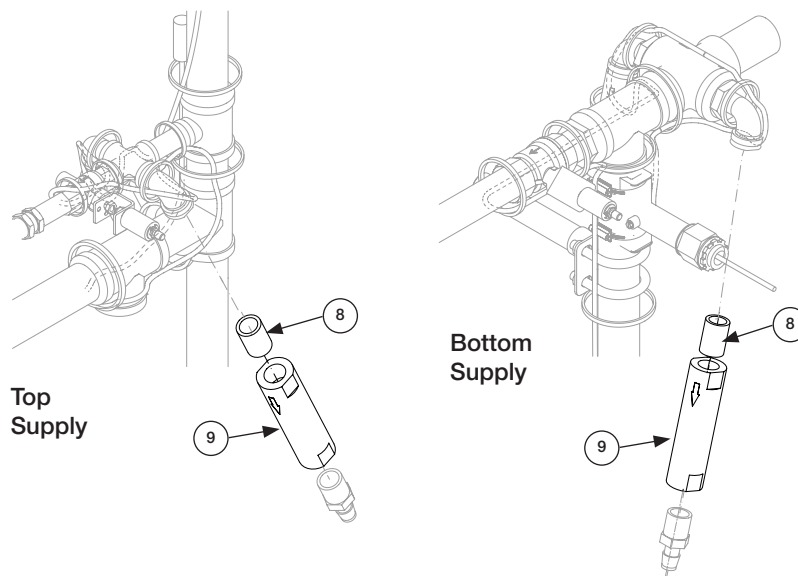

Anti-Freeze and/or Anti-Scald Valve Service Instructions

1. Piping system should be well flushed before replacing the valve.
2. Remove the rivets from the appropriate half of unit so the plastic shell can be pulled away from the unit or removed completely.



Anti-freeze and/or anti-scald valve should be located opposite of the inlet location. Other components may have to be disassembled to remove the shell.

3. Expose the pipe elbow by partially removing the insulation.
4. Remove existing anti-freeze or anti-scald valve and install new valve parts as shown utilizing teflon pipe sealant on threads.
5. Re-route tube through the provided hole in the shell.
6. Flow should be in the direction shown on the nameplate of the valve.

⚠ CAUTION Never insulate or heat trace the anti-scald valve body. The anti-scald valve must heat to sense over-temperature line flow and open.

⚠ CAUTION The anti-freeze valve body must have the heating cable properly re-attached.

NOTICE! Temperature control point is factory set and sealed. Do not adjust; tampering with valve set point or cap will void the warranty.



If rubber tubing (269-1285) and hose barb (269-1296) cannot be re-used, parts are available for purchase. Approximately 1 foot of rubber tubing per valve is required.

S65-443 - Lower Shell Kit

Item	Qty	Description
401	1	Shell, Lower Right
400	1	Shell, Lower Left
406*	1	Rivet, 5mm, Plastic-Push

*Ship as bag of 15 rivets, not shown.

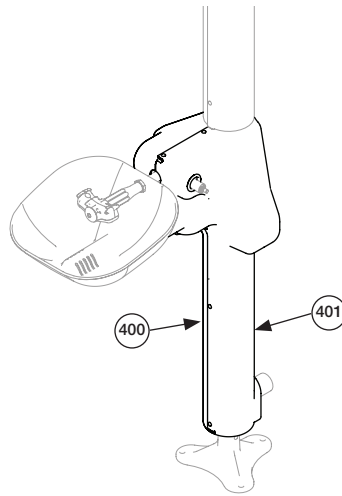

S65-442 - Mid Shell Kit with Drench Hose Option

Item	Qty	Description
403	1	Shell, Center Right, Drench Hose Only
402	1	Shell, Center Left
406*	1	Rivet, 5mm, Plastic-Push

*Ship as bag of 15 rivets, not shown.

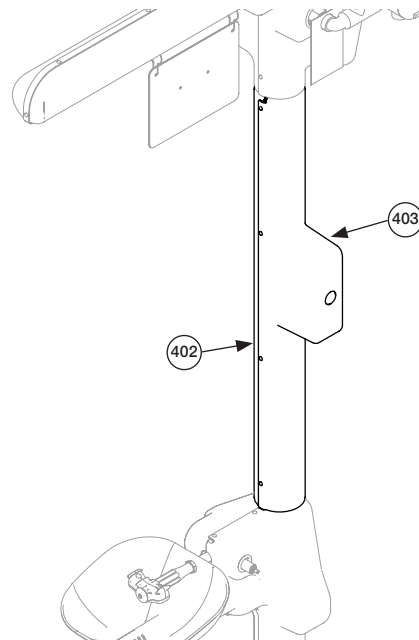

S65-441 - Mid Shell Kit, Less Drench Hose Option

Item	Qty	Description
402	2	Shell, Center Left**
406*	1	Rivet, 5mm, Plastic-Push

*Ships as bag of 15 rivets, not shown.

**Center Left shell works for both left and right side.

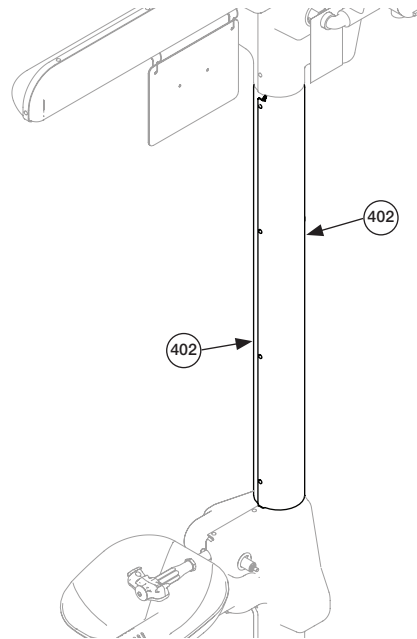

S65-440 - Upper Shell Kit (Basic)

Item	Qty	Description
405	1	Shell, Upper Right
404	1	Shell, Upper Left
406*	1	Rivet, 5mm, Plastic-Push

*Ships as bag of 15 rivets, not shown.

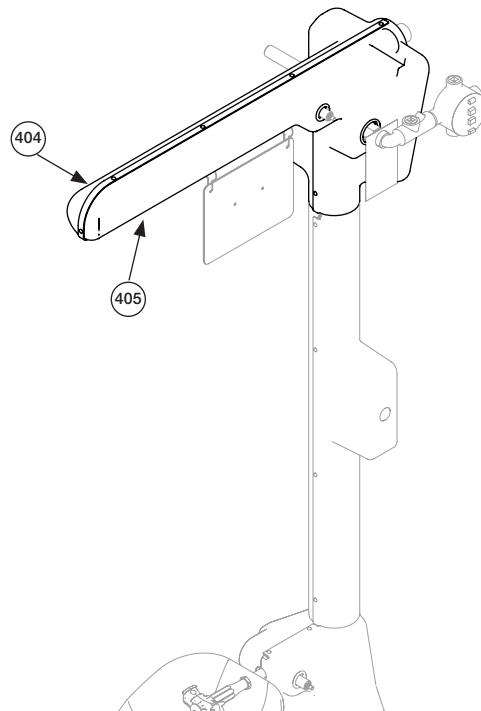

Insulation

If insulation cannot be re-used, below are the service part numbers based on the unit's section of insulation being replaced.

Unit Section of Insulation Needing Replacement	Replacement Insulation Part Number
Insulation over 1" to 1-1/4" fittings or ball valves	269-2586
Insulation over 1" to 1-1/4" pipe only	269-2585
Insulation over 1/2" ball valves or scald or freeze valves	269-2584



When replacing insulation, replace it with the same size and length it was originally built with to ensure unit continues to function properly. Insulation comes in (1) 6 foot stick and should be cut to length by customer. Insulation will need to be re-taped using super heavy duty tape to reseal.

Replacement Base

Painted Galvanized (131-059)
 304 Stainless Steel (131-062)
 316 Stainless Steel (131-079)

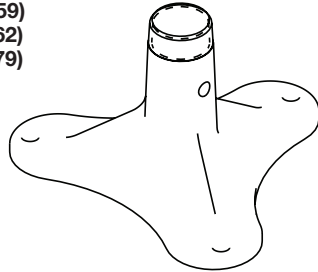

Sign Mounting Bracket (140-1188)

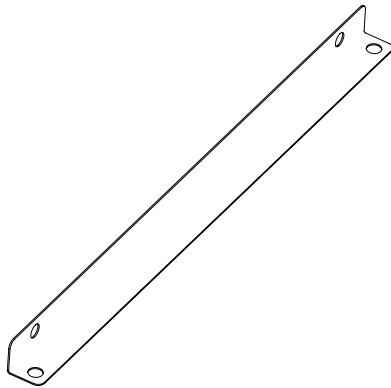

Replacement Rivets (15) (S65-439)



Cleaning and Maintenance for Stainless Steel

Material Description: Stainless steel is extremely durable, and maintenance is simple and inexpensive. Proper care, particularly under corrosive conditions, is essential. Always start with the simplest solution and work your way toward the more complicated.

Routine cleaning: Daily or as often as needed use a solution of warm water and soap, detergent, or ammonia. Apply the cleaning solution per the manufacturer's instructions and always use a soft cloth or sponge to avoid damaging the finish.

Stubborn Stains: To remove stains from stainless steel use a stainless steel cleaner and polish such as Ball® stainless steel cleaner or a soft abrasive. Always follow the manufacturer's instructions and apply in the same direction as the polish lines.

NOTICE! Never use ordinary steel wool or steel brushes on stainless steel. Always use stainless steel wool or stainless steel brushes.

Fingerprints and Smears: To remove fingerprints or smears use a high quality stainless steel cleaner and polish in accordance with the manufacturer's instructions. Many of these products leave a protective coating that helps prevent future smears and fingerprints.

Grease and Oil: To remove grease and oil use a quality commercial detergent or caustic cleaner. Apply in accordance to the manufacturer's instructions and in the direction of the polish lines.

Precautions: Avoid prolonged contact with chlorides (bleaches, salts), bromides (sanitizing agents), thiocyanates (pesticides, photography chemicals, and some foods), and iodides on stainless steel equipment, especially if acid conditions exist.

NOTICE! Do not permit salty solutions to evaporate and dry on stainless steel.

The appearance of rust streaks on stainless steel leads to the belief that the stainless steel is rusting. Look for the actual source of the rust in some iron or steel particles which may be touching, but not actually a part of the stainless steel structure.

NOTICE! Strongly acidic or caustic cleaners may attack the steel causing a reddish film to appear. The use of these cleaners should be avoided.

Brand Names

Use of brand names is intended only to indicate a type of cleaner. This does not constitute an endorsement, nor does the omission of any brand name cleaner imply inadequacy. Many products named are regional in distribution, and can be found in local supermarkets, department and hardware stores, or through your cleaning service. It is emphasized that all products should be used in strict accordance with package instructions.