

Installation

Stainless Steel Restroom Partitions Floor-Mounted with Overhead Brace Series 400

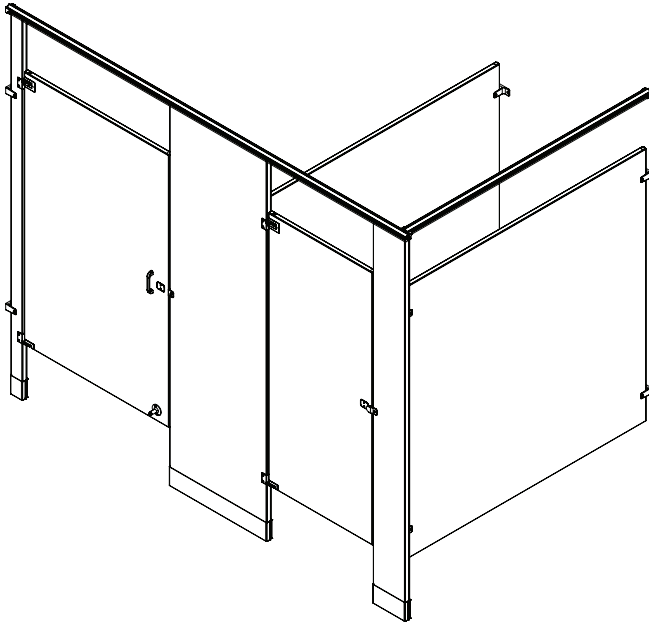

**For Standard Height
Doors and Panels Only**

Table of Contents

Safety Information	2
Supplies Required	3
Hardware Provided	3
Example of Submittal Drawing	3
Layout Dimensions for Brackets	4
Mounting Brackets to Wall	5-6
Leveling Bolts to Pilaster	6
Pilaster Mounting Hardware	7-8
Pilasters and Panels	9-11
Telescoping & Wall-Hung Pilasters	12-15
Headrail	16
Pilaster Shoes	17
Hinges	18-21
Door Hardware	22-25
Urinal Screens	26-28



[Scan or click code to view
Installation Guide \(English\)](#)



[Scan or click code to view
Installation Guide \(French\)](#)



[Scan or click code to view
Installation Guide \(Spanish\)](#)



Read the instructions in this manual before beginning installation. Save these instructions and refer to them for inspection, maintenance and troubleshooting information.

For questions regarding the operation, installation or maintenance of this product, visit bradleycorp.com or call 800.BRADLEY (800.272.3539).

Product warranties and parts information may also be found under “Resources” on our website at bradleycorp.com/customerservice/warranty.



HDWT-INSTR-009 Rev. M: ECO 24-14-001

© 2024 Bradley

Page 1 of 28

4/10/2024

P.O. Box 309
Menomonee Falls, WI 53052 USA
800 BRADLEY (800 272 3539)
+1 262 251 6000
bradleycorp.com



A WATTS Brand

Safety Information

WARNING

Before beginning installation, make sure that the wall and floor backing are adequate to support the secure mounting of the toilet compartment units.

NOTICE

To prevent warping, always lay the material flat. Do not lean the material against the wall or stack unevenly.

To prevent "dimpling," extra caution should be taken when instructed to drill through one side of face only.

IMPORTANT











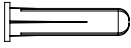
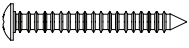

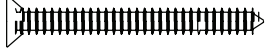



This installation manual provides instruction for the assembly of normal partition configurations and standard components. Non-standard configurations or components including but not limited to curved or angled walls, partial walls, oversized panels, or modified hardware are not covered in this manual. Compliance and conformity to local codes and ordinances is the responsibility of the installer.

Separate parts from packaging and make sure all parts are accounted for before discarding packaging material. If any parts are missing, do not begin installation until you obtain the missing parts.

Supplies Required

- Chalk line and pencil
- Tape measure and 4' level
- Jigsaw (or hacksaw) and circular saw
- Two spring clamps
- 1/8", 9/64", 3/16", 7/32" and 1/4" drill bits
- Power drill or screw gun with drill bit extension
- 1/4" and 5/16" ceramic tile and masonry drill bit
- Hammer drill
- Spacer, 12" (305mm) high and strong enough to support weight of panel

Hardware Provided

						
#1/16" - 18 x 3" Leveling Bolt FAST-S0039	#14-16 Plastic Anchor FAST-T373	#14 x 2" Button-Head Sheet Metal Screw Torx-T27 Drive FAST-P002 (Stainless)	#14 x 2" Button-Head Sheet Metal Screw Torx-T27 Drive FAST-Z002 (Chrome Plated)	#10 x 2" Flat-Head Sheet Metal Screw Torx-T25 Drive Fast-S0023		
						
#14 x 5/8" Button-Head Sheet Metal Screw Torx-T27 Drive FAST-Z0016	#10 x 5/8" Button-Head Sheet Metal Screw Torx-T27 Drive FAST-Z0019	#5-40 x 11/16" Flat-Head Sheet Metal Screw Torx-T10 Drive FAST-T300	#10 x 3/4" Flat-Head Sheet Metal Screw Torx-T25 Drive FAST-Z0006	1/4" - 14 x 5/8" Sheet Metal Screw Torx-T27 Drive FAST-S355A	#10-24 x 3/4" Button-Head Barrel Nut Torx-T27 Drive FAST-Z003 (Chrome Plated)	#10-24 x 3/4" Button-Head Barrel Nut Torx-T27 Drive FAST-P003 (Stainless)
						
#10 x 5/8" Button-Head Sheet Metal Screw Torx-T27 Drive FAST-S351A	#10-24 x 3/4" Button-Head Shoulder Screw Torx-T27 Drive FAST-Z004 (Chrome Plated)	#10-24 x 3/4" Button-Head Shoulder Screw Torx-T27 Drive FAST-P004 (Stainless)	#10-24 x 1" Button-Head Shoulder Screw Torx-T27 Drive FAST-Z004A (Chrome Plated)	#10-24 x 1" Button-Head Shoulder Screw Torx-T27 Drive FAST-P004A (Stainless)	#10 x 2" Flat-Head Machine Screw Torx-T25 Drive FAST-Z0027	

Example of Submittal Drawing

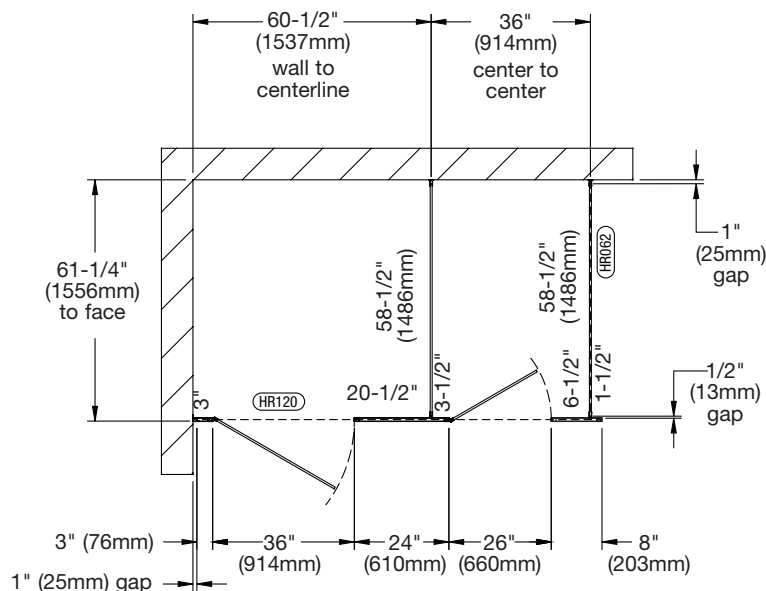

1 Layout Dimensions - Stirrup Brackets (Standard)



When installing the partition components, consult the applicable partition submittal drawing for compartment layout dimensions.

A

Pilaster centerline: Measure from the back wall forward to the face of the compartment, subtract 5/8" (16mm) and mark this location on the floor ("A"). Mark the same measurement on the opposite end of your layout ("A1") and draw a straight line connecting both marks.

For freestanding (FS) partitions: Refer to submittal drawings and determine the approximate location of the outside panels. Establish dimensions "A" and "A1" as explained above.

B

Panel centerline: Measure the stall width across the back wall and place a mark at the base of the rear wall ("B"). Repeat this step for each panel, starting each measurement from the last panel centerline ("B1").

C

Draw a plumb line on all walls from each pilaster and panel centerline. From the highest point in the room, measure 18" (457mm) and 64" (1626mm) from the floor and place a mark on the pilaster/panel plumb line. These marks represent the hole center line of the stirrup brackets. Use a level to transfer that mark to all other plumb lines ("C").

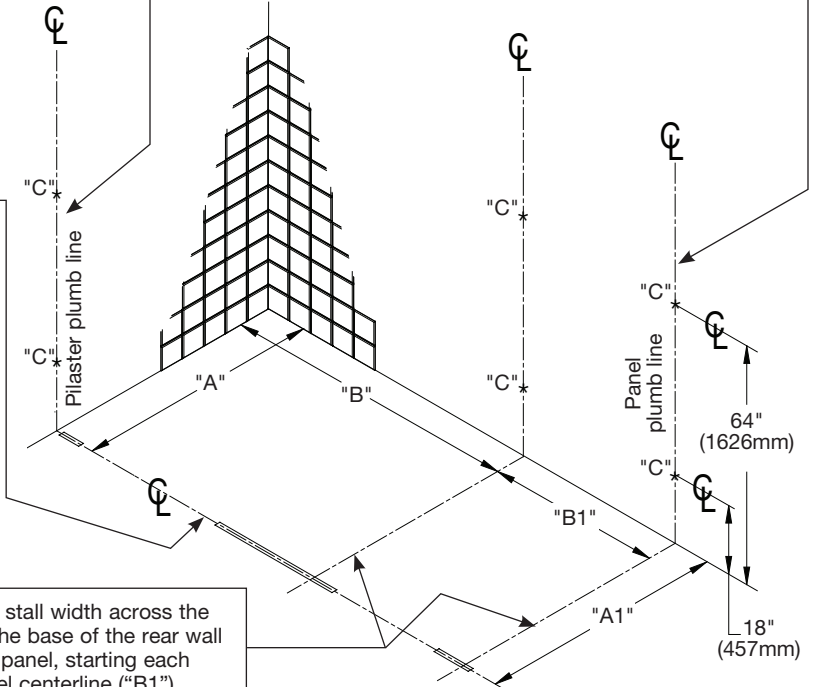

1a Layout Dimensions - Continuous Brackets (Optional)



When installing the partition components, consult the applicable partition submittal drawing for compartment layout dimensions.

A

Pilaster centerline: Measure from the back wall forward to the face of the compartment, subtract 5/8" (16mm) and mark this location on the floor ("A"). Mark the same measurement on the opposite end of your layout ("A1") and draw a straight line connecting both marks.

For freestanding (FS) partitions: Refer to submittal drawings and determine the approximate location of the outside panels. Establish dimensions "A" and "A1" as explained above.

B

Panel centerline: Measure the stall width across the back wall and place a mark at the base of the rear wall ("B"). Repeat this step for each panel, starting each measurement from the last panel centerline ("B1").

C

Draw a plumb line on all walls from each pilaster and panel centerline. From the highest point in the room, measure from the floor and place a mark on the pilaster/panel plumb line at dimension "C" for the respective bracket type (see table below). Use a level to transfer that mark to all other plumb lines "D".

	Dim "C"
Stainless Steel	12-1/2" (318mm)
Aluminum	12-1/4" (311mm)

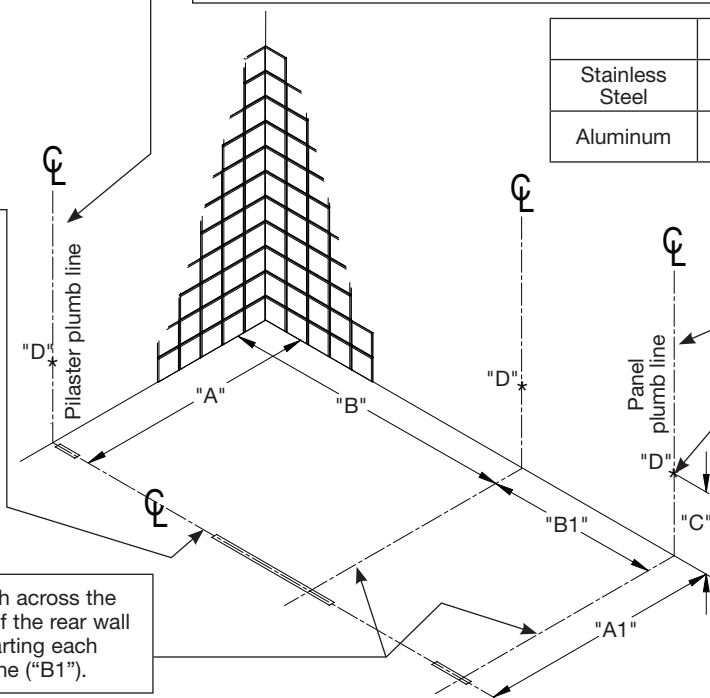

2 Stirrup Brackets to Wall (Standard)

- On end panel and pilaster applications, position the bracket with the ear facing toward the inside of the stall.
- Pilaster bracket is shown here; 1-1/4" opening brackets are for pilasters, and 1" opening brackets are for panels.

A Place the center of each stirrup bracket at the established level line. Center the bracket opening on the pilaster/panel plumb line.

B Using the bracket as a template, mark the hole locations on the wall. Remove the bracket and drill a Ø5/16" hole (min. 2" [51mm] deep) at each hole location.

C Insert the plastic anchors in all holes and secure the brackets to the wall with the #14 x 2" screws provided.

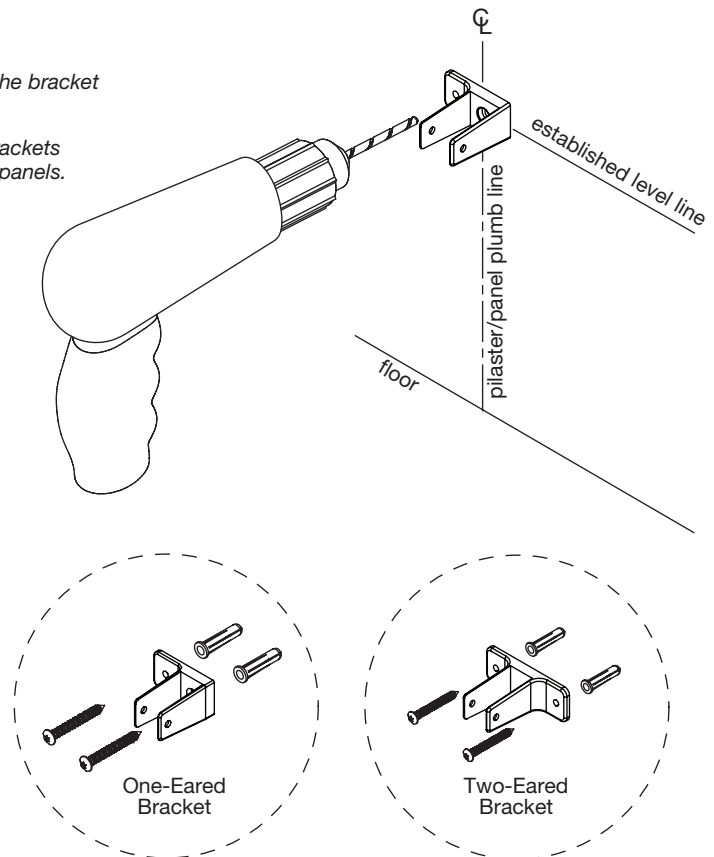

2a Continuous Stainless Steel Brackets to Wall (Optional)

- On pilaster applications, position the bracket with the ear facing toward the inside of the stall.
- Pilaster bracket is shown here; "Ear" brackets are for pilasters, and U-brackets are for panels.
- Brackets are used as templates, but since the hole patterns may be different, the brackets may not be interchangeable.

A Place the bottom of each continuous bracket at the established level line. Center the bracket opening on the pilaster/panel plumb line.

B Using the bracket as a template, mark the hole locations on the wall. Remove the bracket and drill a Ø5/16" hole (min. 2" [51mm] deep) at each hole location.

C Insert the plastic anchors in all holes and secure the brackets to the wall with the #14 x 2" stainless screws provided.

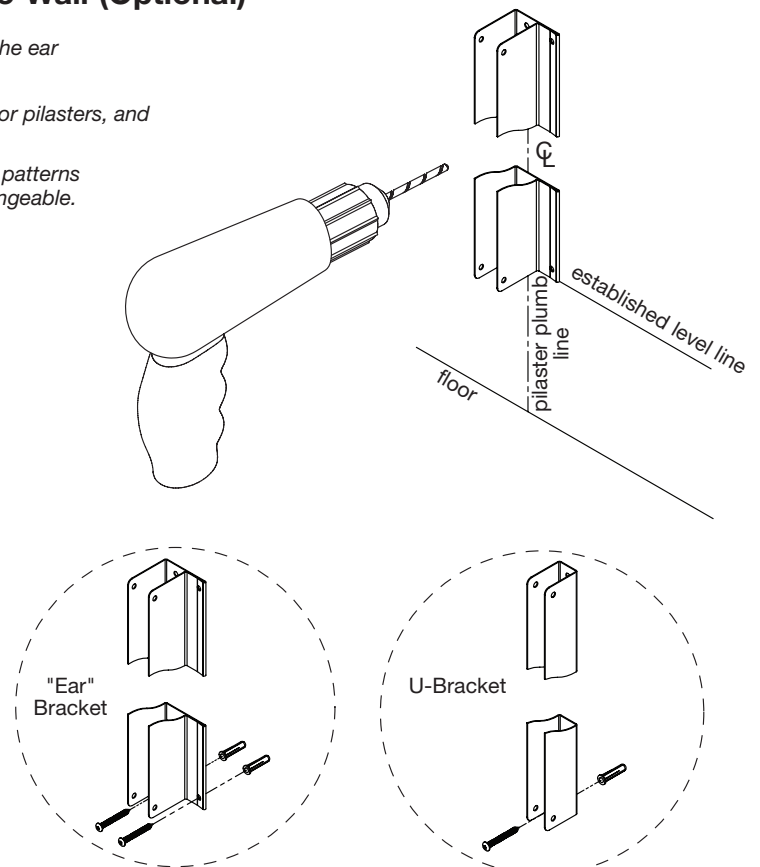

2b Continuous Aluminum Brackets to Wall (Optional)

- ✓ On end panel and pilaster applications, position the bracket with the ear facing toward the inside of the stall.
- ✓ Pilaster bracket is shown here; 1-1/4" opening brackets are for pilasters, and 1" opening brackets are for panels.
- ✓ Brackets are used as templates, but since the hole patterns may be different, the brackets may not be interchangeable.

A Place the bottom of each continuous bracket at the established level line. Center the bracket opening on the pilaster/panel plumb line.

B Using the bracket as a template, mark the hole locations on the wall. Remove the bracket and drill a Ø5/16" hole (min. 2" [51mm] deep) at each hole location.

C Insert the plastic anchors in all holes and secure the brackets to the wall with the #14 x 2" stainless screws provided.

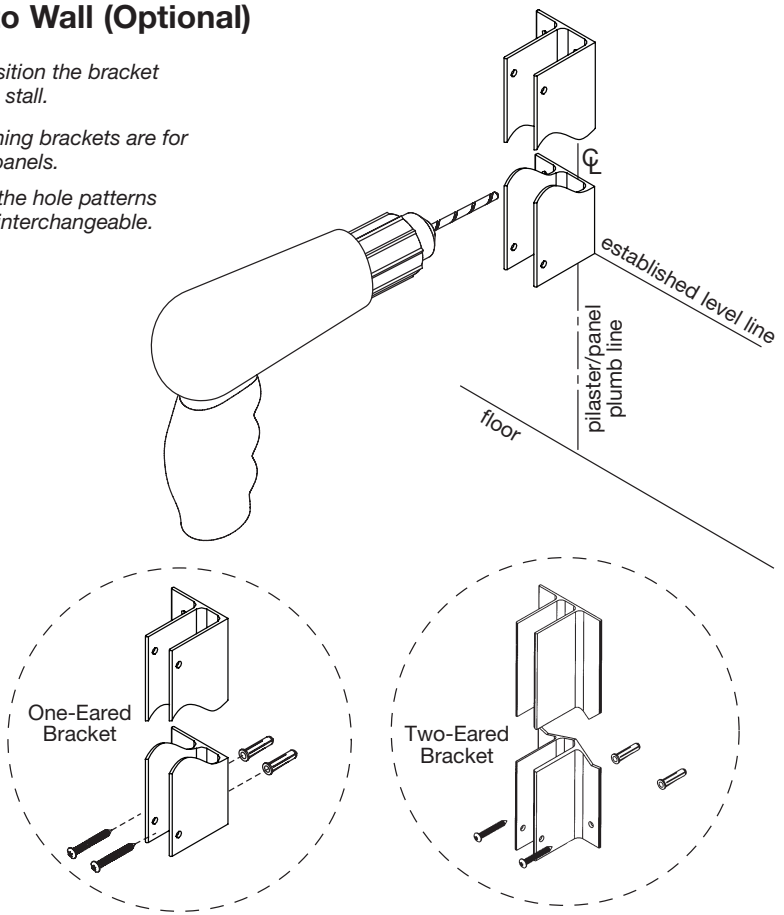

3 Leveling Bolts to Pilaster

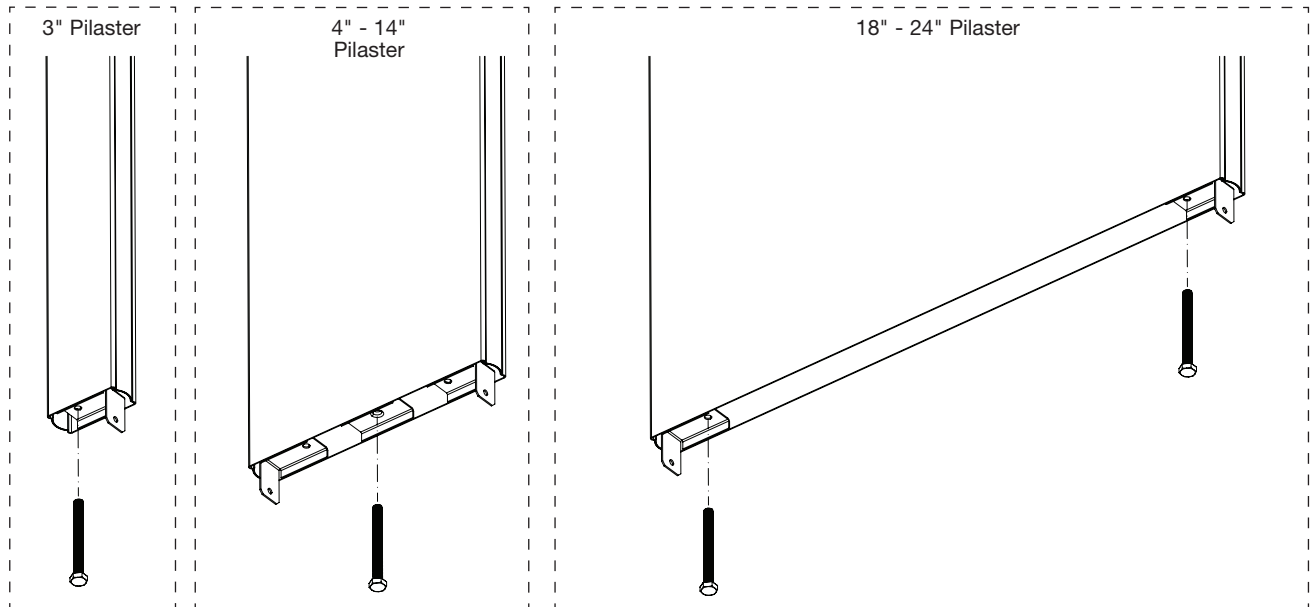

A Use leveling bolt(s) to adjust height of pilaster as indicated based on pilaster width.

- ✓ 4" - 8" pilasters have a single, 1-piece bracket that uses a leveling bolt in the center to adjust the pilaster height.

4 Stirrup Brackets to Pilaster (Standard)

Refer to the submittal drawing to locate the split dimension and layout location of each marked pilaster.

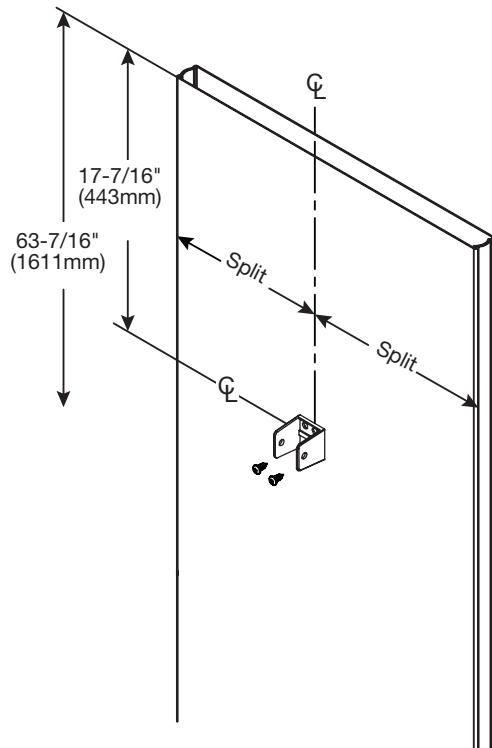

A Measure 17-7/16 (443mm) and 63-7/16" (1611mm) down from the top of each pilaster and place a mark on the pilaster split centerline.

Pilaster shown is for reference only. Actual pilaster varies depending on application.

B Place stirrup brackets at each established level line. Center the bracket opening on the pilaster split centerline. Using the bracket as a template, mark the hole locations on the pilaster. Remove the bracket and drill a Ø3/16" pilot hole (through inside face of pilaster only) at each location.

C Secure the stirrup brackets to the pilasters using the #14 x 5/8" screws provided.

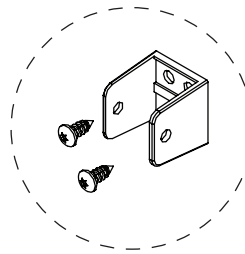

4a Continuous Brackets to Pilaster (Optional)

Refer to the submittal drawing to locate the split dimension and layout location of each marked pilaster.

Brackets are used as templates but since the hole patterns may be different, the brackets may not be interchangeable.

Continuous stainless steel bracket shown.

	Dim. "A"	Dim. "B"
Stainless Steel Bracket	11-15/16" (302mm)	69-15/16" (1749mm)
Aluminum Bracket	11-11/16" (297mm)	69-3/16" (1749mm)

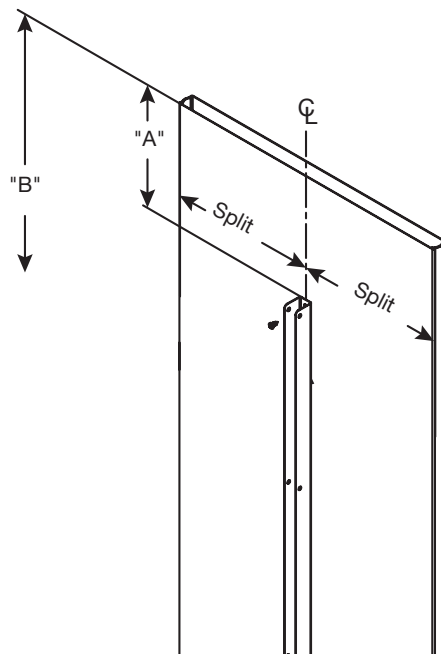

A Measure down from the top of the pilaster and place a mark on the pilaster split centerline at dimensions "A" and "B" for the respective bracket (see table at left).

Pilaster shown is for reference only. Actual pilaster varies depending on application.

B Place the continuous bracket between each established level line. Center the bracket opening on the pilaster split centerline. Using the bracket as a template, mark the hole locations on the pilaster. Remove the bracket and drill a Ø3/16" pilot hole (through inside face of pilaster only) at each location.

C Secure the continuous bracket to the pilasters using the #14 x 5/8" stainless screws provided.

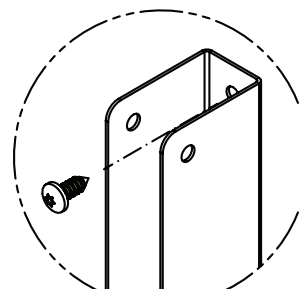

4b Alcove Brackets to Pilaster

Layouts that use continuous aluminum brackets for pilaster and panel connections will use stirrup brackets for alcove connections. Continuous stainless steel brackets use continuous alcove brackets.

Refer to the submittal drawing for the layout location of each alcove pilaster.

A Measure down from the top of the pilaster and place a mark at dimensions shown for the respective bracket situation.

B **Stirrup:** Position the center of each bracket at the marks made in Step A.
Continuous: Center the bracket between each mark made in Step A.

C Using the bracket as a template, mark the hole locations on the pilaster. Remove the bracket and drill $\text{\O}3/16"$ holes through the pilaster at each location.

D Secure the bracket(s) to the pilaster using the #14 x 5/8" screws (stainless on continuous) provided.

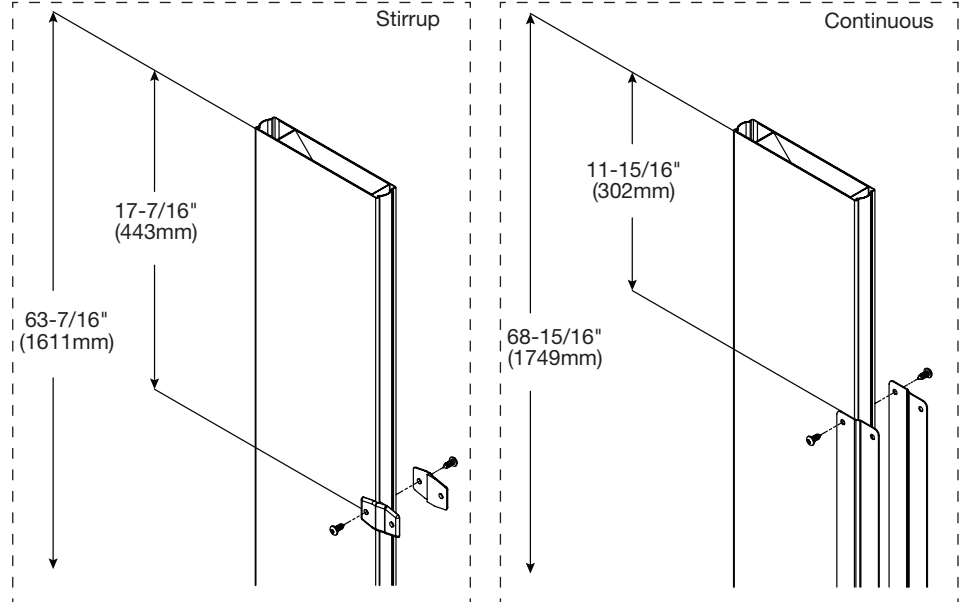

5 Pilaster Mounting Hardware

A This view is an example only. Refer to your submittal drawings to determine placement of the anchors on the pilaster centerline for your application. Typical anchor centers are measured 1" (25mm) in from each edge of the pilaster (except 3" pilasters where only one anchor is used).

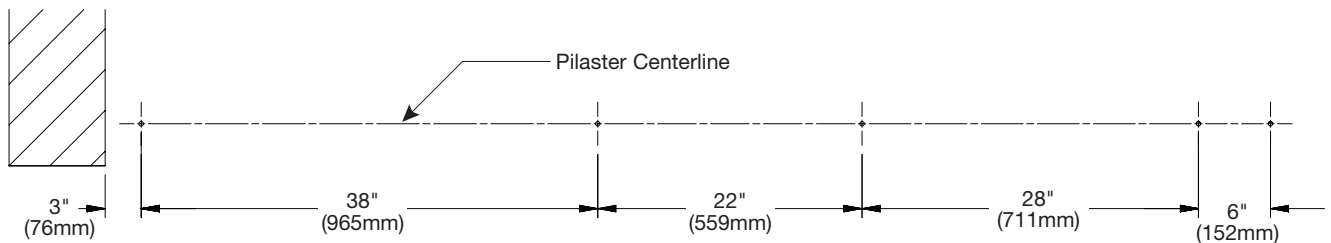

B Drill $\text{\O}5/16"$ holes (min 2" [51mm] deep) in the floor and make sure the holes are free of dirt and debris.

C Insert plastic anchors into the holes and fasten the "L" brackets to the anchors using the #14 x 2" screws provided.

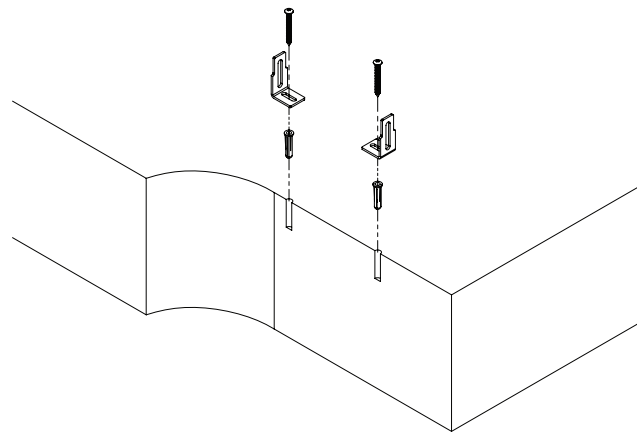

6 Pilasters and Panels with Stirrup Brackets (Standard)

- Pilasters located at walls should be mounted first. Start at one end and install a panel, then a pilaster. Continue alternating until installation is complete. When installing in an alcove or in-corner, use an alcove bracket to secure the pilaster to the panel.
- Check to make sure the pilasters are plumb and level to each other. The pilaster height can be adjusted with the leveling bolt that was placed at the bottom of the pilaster (see page 4 for attaching leveling bolt).

Pilasters at Wall

- When installing pilasters at walls, the gaps range from 1/2" to 1-1/4" (13mm to 32mm). Refer to your submittal drawing for your gap sizes.

A Slide the shoe onto the bottom of the pilaster and use a piece of tape to keep the shoe positioned above the mounting hardware. Make sure the shoe mounting hole is facing inside the stall and that the hole is towards the top.

B Position the pilaster so the mounting bracket(s) sits on the inside of the floor "L" bracket(s) while at the same time placing the pilaster within the wall brackets. Secure the pilaster mounting bracket(s) to the floor "L" bracket(s) using the #14 x 5/8" screw(s) provided.

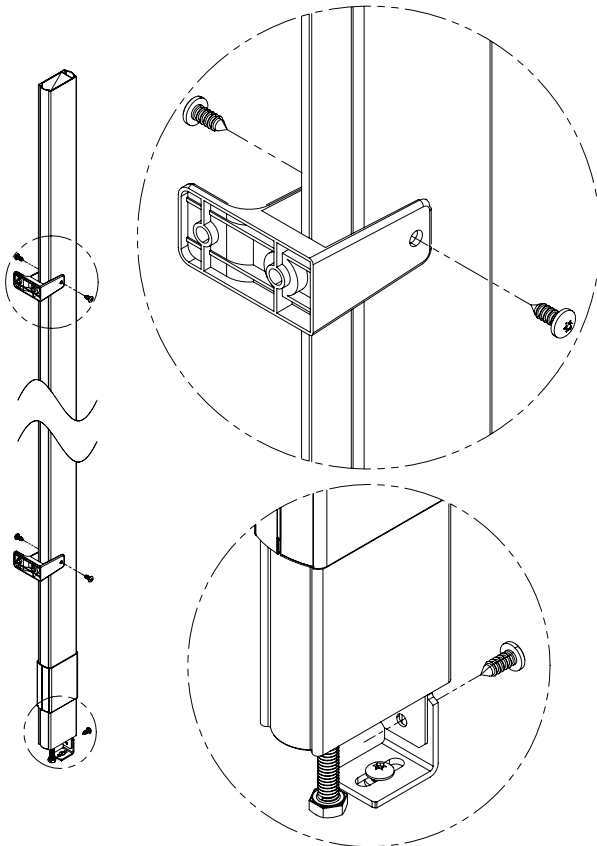

C Using the bracket as a template, drill Ø3/16" holes through the pilaster at each pilaster bracket hole. Secure the pilaster to the bracket using the #14 x 5/8" screws provided.

Pilasters with Panels

- Refer to your submittal drawing and leave the appropriate gaps. Standard gap is 1" (25mm) between the panel and wall and 1/2" (13mm) between the panel and pilaster.

A Place the panel on the spacer and insert the panel into the wall brackets.

B Slide the shoe onto the bottom of the pilaster and use a piece of tape to keep the shoe positioned above the mounting hardware. Make sure the shoe mounting hole is facing inside the stall and that the hole is towards the top.

C Position the pilaster so the mounting bracket(s) sits on the inside of the floor "L" bracket(s) while at the same time placing the brackets around the panel. Secure the pilaster mounting bracket(s) to the floor "L" bracket(s) using the #14 x 5/8" screw(s) provided.

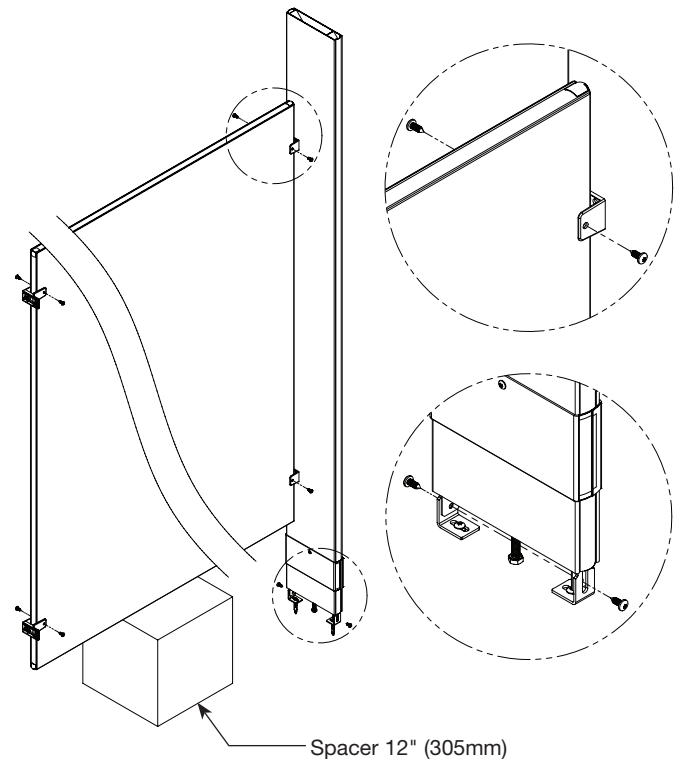

D Using the bracket as a template, drill Ø3/16" holes through the panel at each panel bracket hole. Secure the panel to the bracket using the #14 x 5/8" screws provided.

6a Pilasters and Panels with Stainless Steel Continuous Brackets (Optional)

- Pilasters located at walls should be mounted first. Start at one end and install a panel, then a pilaster. Continue alternating until installation is complete. When installing in an alcove or in-corner, use an alcove bracket to secure the pilaster to the panel.
- Check to make sure the pilasters are plumb and level to each other. The pilaster height can be adjusted with the leveling bolt that was placed at the bottom of the pilaster (see page 4 for attaching leveling bolt).

Pilasters at Wall

- When installing pilasters at walls, the gaps range from 1/2" to 1-1/4" (13mm to 32mm). Refer to your submittal drawing for your gap sizes.

A Slide the shoe onto the bottom of the pilaster and use a piece of tape to keep the shoe positioned above the mounting hardware. Make sure the shoe mounting hole is facing inside the stall and that the hole is towards the top.

B Position the pilaster so the mounting bracket(s) sits on the inside of the floor "L" bracket(s) while at the same time placing the pilaster within the wall bracket. Secure the pilaster mounting bracket(s) to the floor "L" bracket(s) using the #14 x 5/8" screw(s) provided.

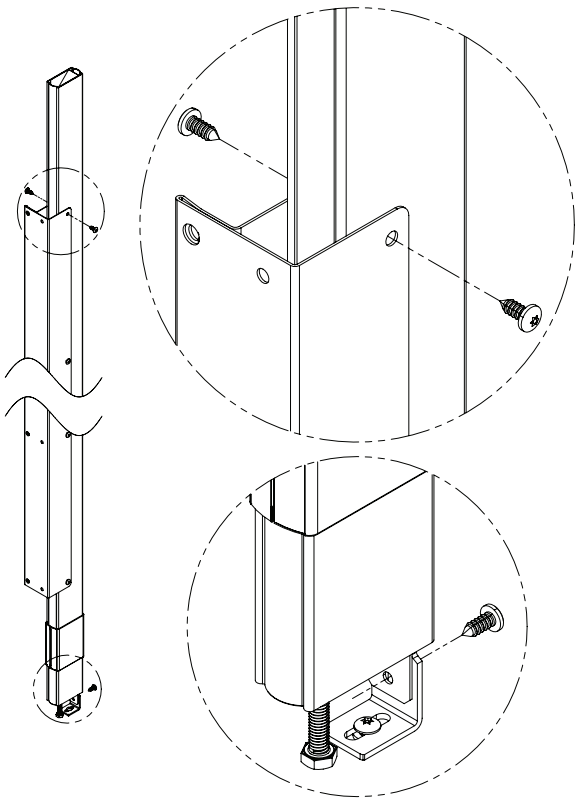

C Using the bracket as a template, drill Ø3/16" holes through the pilaster at each pilaster bracket hole. Secure the pilaster to the bracket using the #14 x 5/8" stainless screws provided.

Pilasters with Panels

- Refer to your submittal drawing and leave the appropriate gaps. Standard gap is 1" (25mm) between the panel and wall and 1/2" (13mm) between the panel and pilaster.

A Place the panel on the spacer and insert the panel into the wall bracket.

B Slide the shoe onto the bottom of the pilaster and use a piece of tape to keep the shoe positioned above the mounting hardware. Make sure the shoe mounting hole is facing inside the stall and that the hole is towards the top.

C Position the pilaster so the mounting bracket(s) sits on the inside of the floor "L" bracket(s) while at the same time placing the bracket around the panel. Secure the pilaster mounting bracket(s) to the floor "L" bracket(s) using the #14 x 5/8" screw(s) provided.

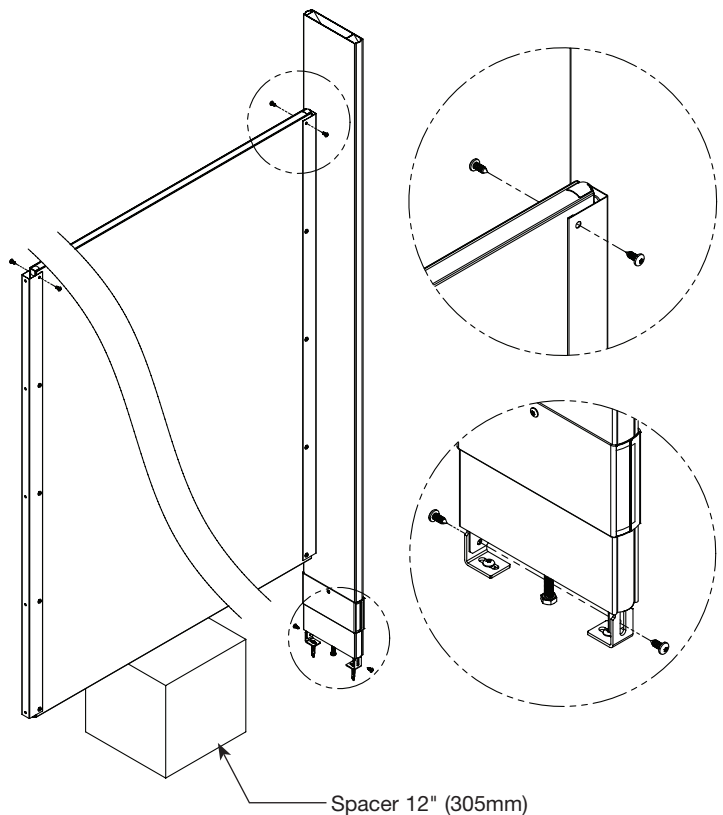

D Using the bracket as a template, drill Ø3/16" holes through the panel at each panel bracket hole. Secure the panel to the bracket using the #14 x 5/8" stainless screws provided.

6b Pilasters and Panels with Aluminum Continuous Brackets (Optional)

- Pilasters located at walls should be mounted first. Start at one end and install a panel, then a pilaster. Continue alternating until installation is complete. When installing in an alcove or in-corner, use an alcove bracket to secure the pilaster to the panel.
- Check to make sure the pilasters are plumb and level to each other. The pilaster height can be adjusted with the leveling bolt that was placed at the bottom of the pilaster (see page 4 for attaching leveling bolt).

Pilasters at Wall

- When installing pilasters at walls, the gaps range from 1/2" to 1-1/4" (13mm to 32mm). Refer to your submittal drawing for your gap sizes.

A Slide the shoe onto the bottom of the pilaster and use a piece of tape to keep the shoe positioned above the mounting hardware. Make sure the shoe mounting hole is facing inside the stall and that the hole is towards the top.

B Position the pilaster so the mounting bracket(s) sits on the inside of the floor "L" bracket(s) while at the same time placing the pilaster within the wall bracket. Secure the pilaster mounting bracket(s) to the floor "L" bracket(s) using the #14 x 5/8" screw(s) provided.

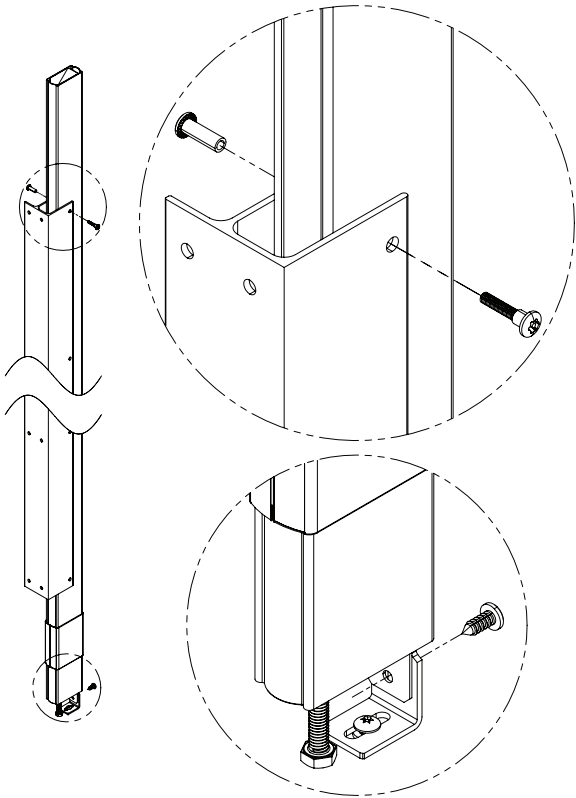

C Using the bracket as a template, drill $\text{\O}1/4"$ holes through the pilaster at each pilaster bracket hole. Secure the pilaster to the bracket using the #10-24 x 3/4" stainless barrel nuts and #10-24 x 1" stainless shoulder screws provided.

Pilasters with Panels

- Refer to your submittal drawing and leave the appropriate gaps. Standard gap is 1" (25mm) between the panel and wall and 1/2" (13mm) between the panel and pilaster.

A Place the panel on the spacer and insert the panel into the wall bracket.

B Slide the shoe onto the bottom of the pilaster and use a piece of tape to keep the shoe positioned above the mounting hardware. Make sure the shoe mounting hole is facing inside the stall and that the hole is towards the top.

C Position the pilaster so the mounting bracket(s) sits on the inside of the floor "L" bracket(s) while at the same time placing the bracket around the panel. Secure the pilaster mounting bracket(s) to the floor "L" bracket(s) using the #14 x 5/8" screw(s) provided.

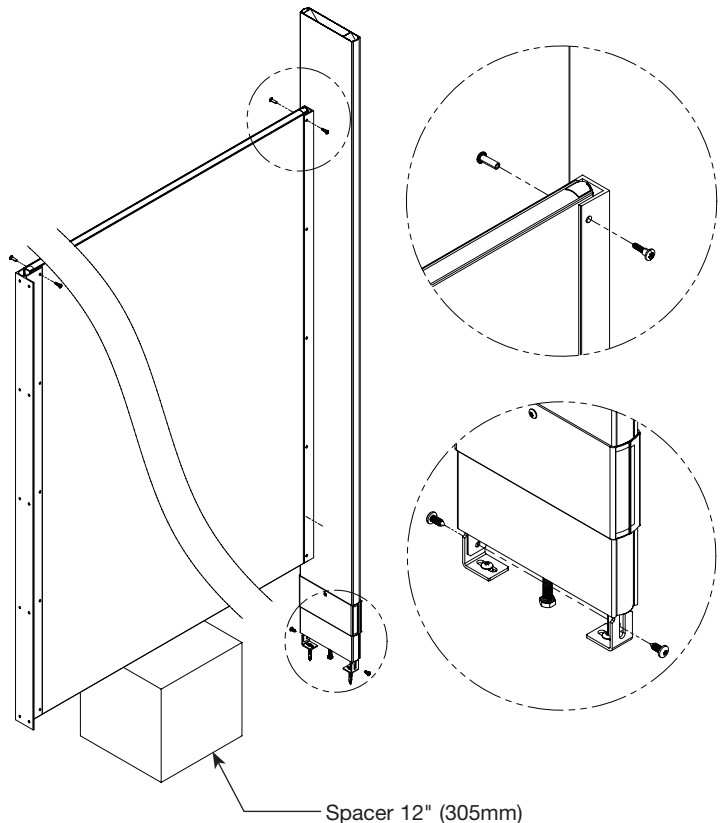

D Using the bracket as a template, drill $\text{\O}1/4"$ holes through the panel at each panel bracket hole. Secure the panel to the bracket using the #10-24 x 3/4" stainless barrel nuts and #10-24 x 3/4" stainless shoulder screws provided.

6c Telescoping Pilasters (Optional)

Mounting channels are used as templates but may not be interchangeable because the hole patterns may be different.

A **Wall:** From the highest point in the room, measure 12-1/8" (308mm) up from the floor and transfer this level line to the pilaster plumb line. Place the bottom of the mounting channel at the level line and center the channel opening on the plumb line.
Pilaster: Measure 12-5/16" (313mm) down from the top of the pilaster and place a mark on the pilaster centerline. Place the top of the mounting channel at this mark and center the channel opening on the centerline.

B **Wall:** Using the mounting channel as a template, mark the hole locations and remove mounting channel. Drill a Ø5/16" hole (min 2" [51mm] deep) at each hole location.
Pilaster: Using the mounting channel as a template, mark the hole locations and remove the mounting channel. Drill a Ø1/4" hole through the pilaster.

C **Wall:** Insert the plastic anchors in all holes and secure the mounting channel to the wall with the #14 x 2" screws provided.
Pilaster: Secure the mounting channel to the pilaster with the #10-24 x 3/4" barrel nuts and the #10-24 x 1" shoulder screws provided.

D Slide the telescoping channel over the mounting channel. Refer to the submittal drawings and adjust the width to meet the specified dimension.

E Using the holes in the telescoping channel as a template, drill Ø3/16" holes through the mounting channel. Secure the telescoping channel to the mounting channel with the #14 x 5/8" screws provided.

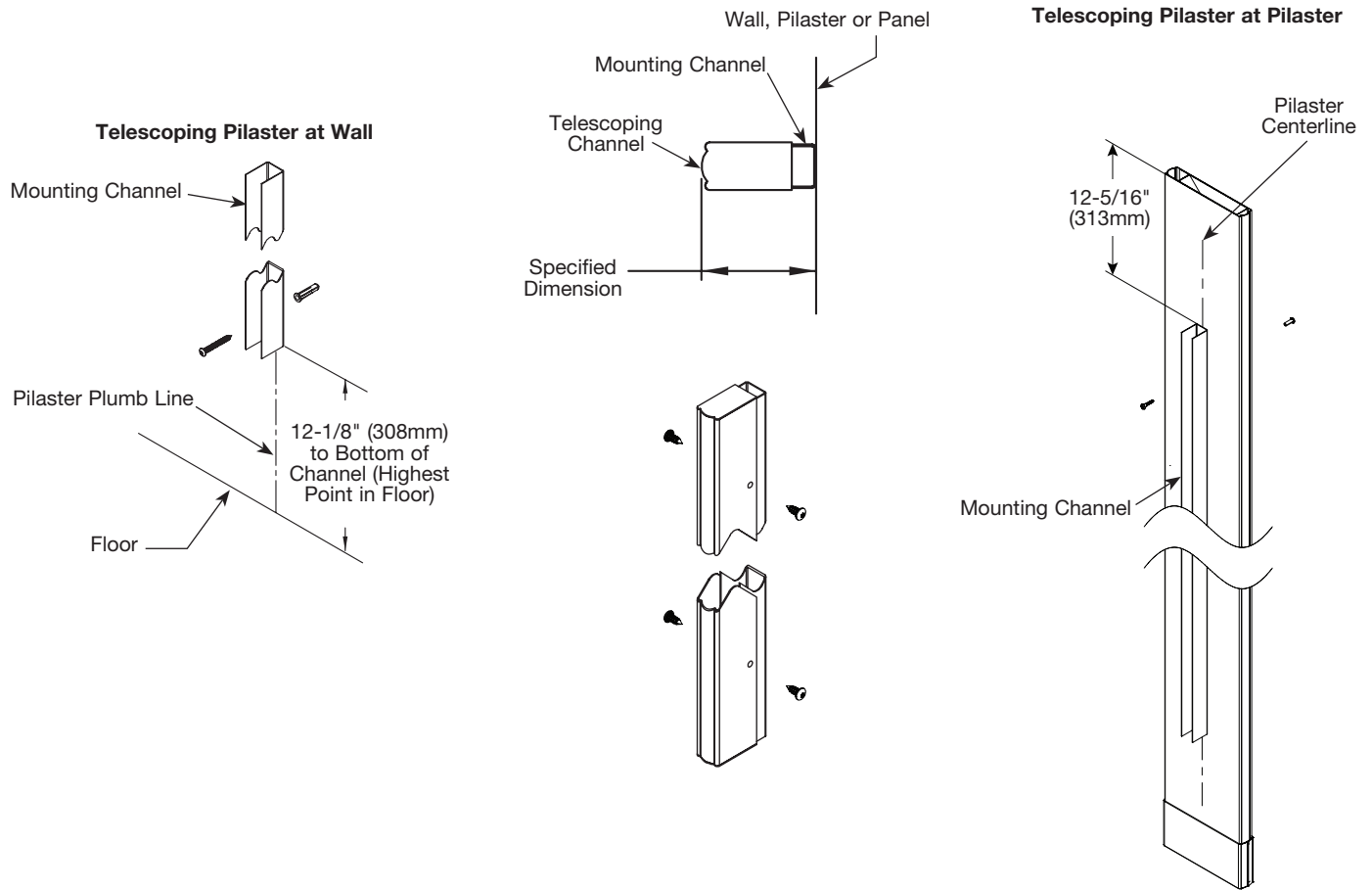

6d Wall-Hung Pilasters (58" or 69-9/16") - Stirrup Brackets (Optional)

- See Step 2 for instructions on mounting the stirrup brackets to a wall.
- See Step 4 for instructions on mounting the stirrup brackets to a pilaster.
- To establish level line, from the highest point in the room, measure 12" (305mm) from the floor. Use a level to transfer this mark to the pilaster plumb line.
- Pilasters shown in two different lengths for visual reference.

Pilasters at Wall

A Slide the wall-hung pilaster into the stirrup brackets and align with the established level line. Refer to the submittal drawing and adjust to meet the specified dimension.

B Using the stirrup brackets as a template, drill $\text{Ø}3/16"$ holes through the pilaster at each bracket hole. Secure the pilaster to the bracket using the #14 x 5/8" screws provided.

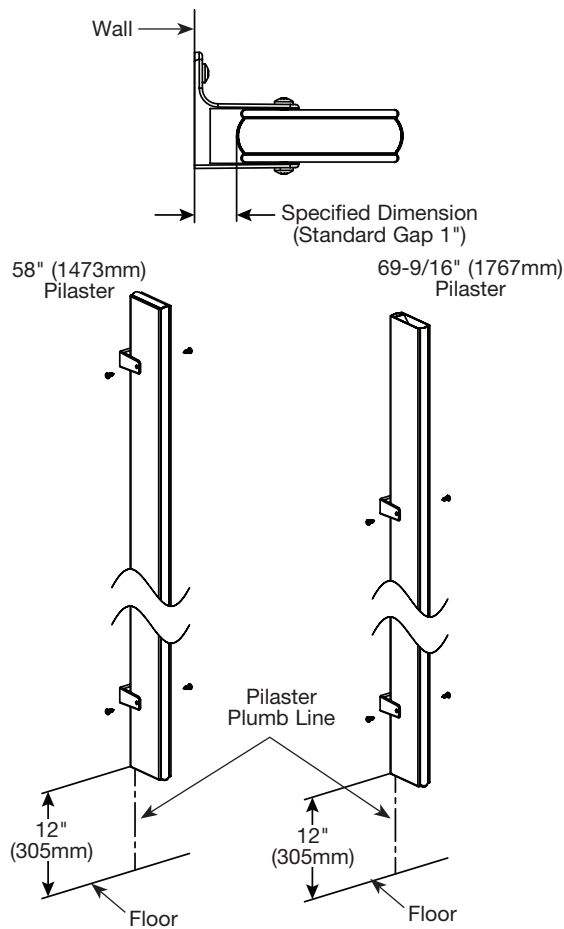

Pilasters at Pilasters

A Slide the wall-hung pilaster into the stirrup brackets and align with the established level line. Refer to the submittal drawing and adjust to meet the specified dimension.

B Using the stirrup brackets as a template, drill $\text{Ø}3/16"$ holes through the pilaster at each bracket hole. Secure the pilaster to the bracket using the #14 x 5/8" screws provided.

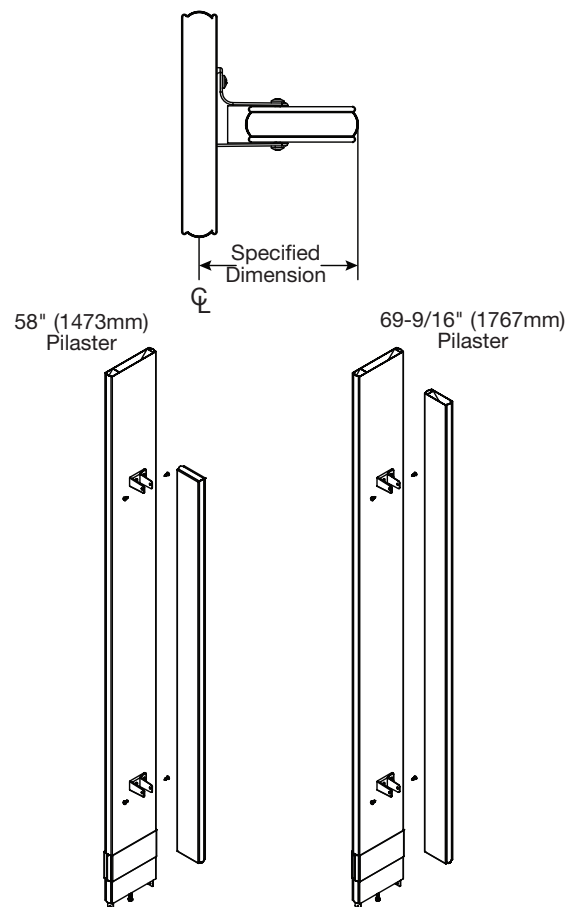

6e Wall-Hung Pilasters (58" or 69-9/16") - Continuous Stainless Steel Brackets (Optional)

- ✓ See Step 2a for instructions on mounting the continuous stainless steel brackets to a wall.
- ✓ See Step 4a for instructions on mounting the continuous stainless steel brackets to a pilaster.
- ✓ To establish level line, from the highest point in the room, measure 12" (305mm) from the floor. Use a level to transfer this mark to the pilaster plumb line.
- ✓ Pilasters shown in two different lengths for visual reference.

Pilasters at Wall

A Slide the wall-hung pilaster into the continuous bracket and align with the established level line. Refer to the submittal drawing and adjust to meet the specified dimension.

B Using the continuous bracket as a template, drill $\text{Ø}3/16"$ holes through the pilaster at each bracket hole. Secure the pilaster to the bracket using the #14 x 5/8" stainless screws provided.

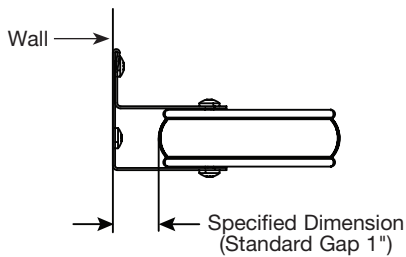

58" (1473mm) Pilaster

69-9/16" (1767mm) Pilaster

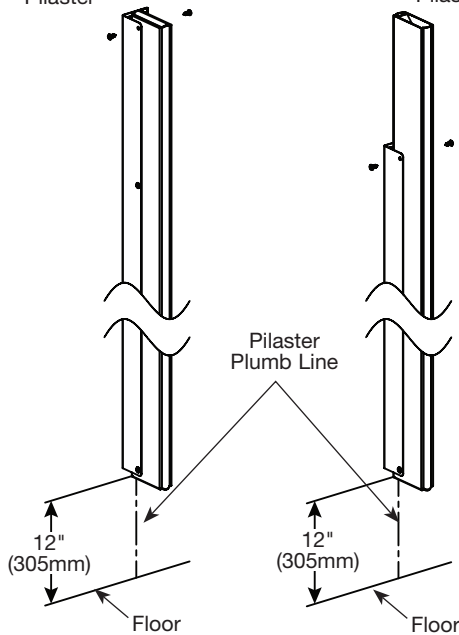

Pilasters at Pilasters

A Slide the wall-hung pilaster into the continuous bracket and align with the established level line. Refer to the submittal drawing and adjust to meet the specified dimension.

B Using the continuous bracket as a template, drill $\text{Ø}3/16"$ holes through the pilaster at each bracket hole. Secure the pilaster to the bracket using the #14 x 5/8" stainless screws provided.

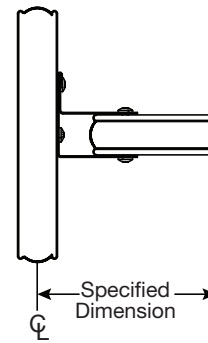

58" (1473mm) Pilaster

69-9/16" (1767mm) Pilaster

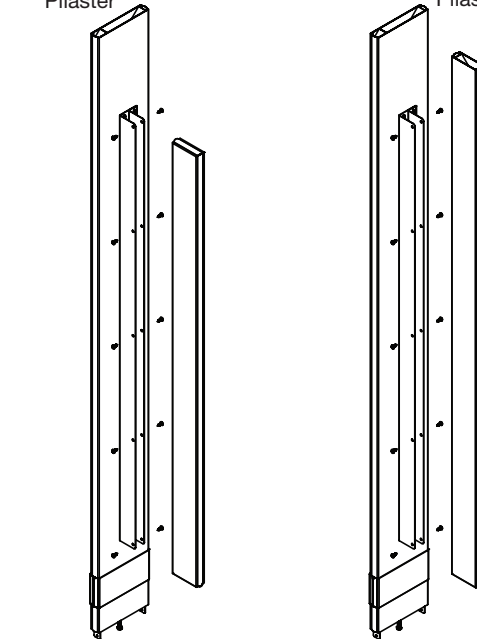

6f Wall-Hung Pilasters (58" or 69-9/16") - Continuous Aluminum Brackets (Optional)

- ✓ See Step 2b for instructions on mounting the continuous aluminum brackets to a wall.
- ✓ See Step 4a for instructions on mounting the continuous aluminum brackets to a pilaster.
- ✓ To establish level line, from the highest point in the room, measure 12" (305mm) from the floor. Use a level to transfer this mark to the pilaster plumb line.
- ✓ Pilasters shown in two different lengths for visual reference.

Pilasters at Wall

A Slide the wall-hung pilaster into the continuous bracket and align with the established level line. Refer to the submittal drawing and adjust to meet the specified dimension.

B Using the continuous bracket as a template, drill $\text{\O}1/4"$ holes through the pilaster at each bracket hole. Secure the pilaster to the bracket using the #10-24 x 3/4" stainless barrel nuts and #10-24 x 1" stainless shoulder screws provided.

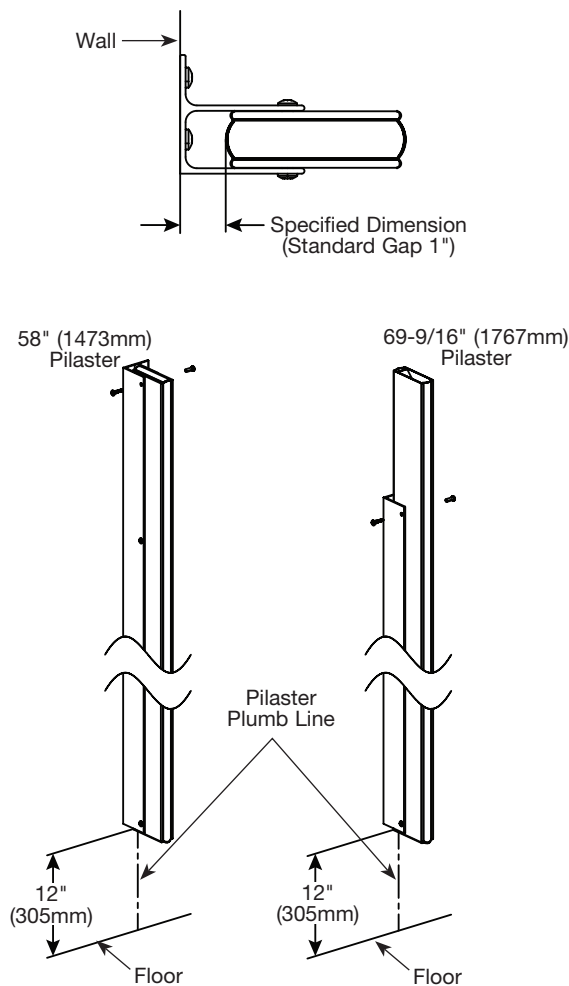

Pilasters at Pilasters

A Slide the wall-hung pilaster into the continuous bracket and align with the established level line. Refer to the submittal drawing and adjust to meet the specified dimension.

B Using the continuous bracket as a template, drill $\text{\O}1/4"$ holes through the pilaster at each bracket hole. Secure the pilaster to the bracket using the #10-24 x 3/4" stainless barrel nuts and #10-24 x 1" stainless shoulder screws provided.

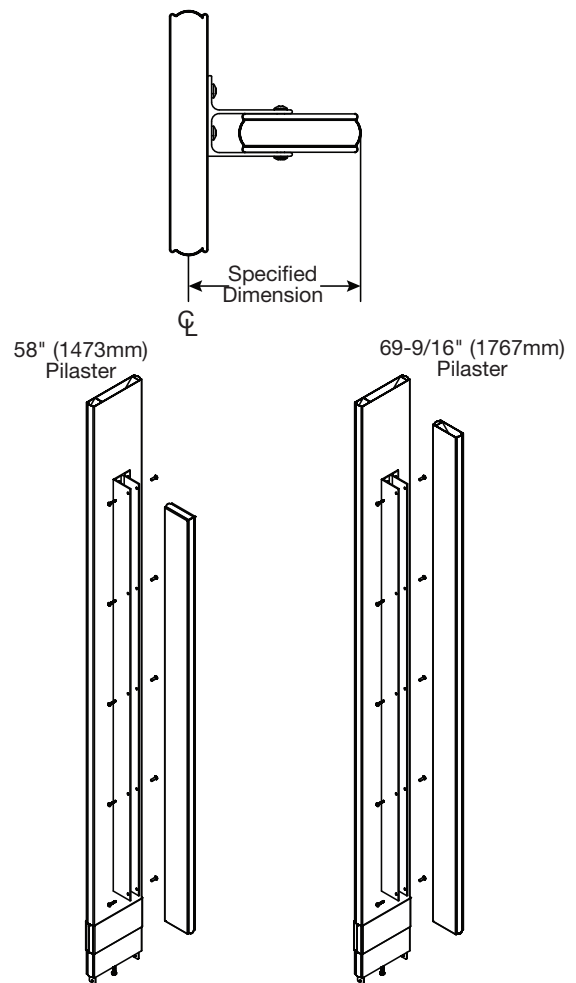

7 Headrail

- ✓ Make sure the pilasters are plumb and that the pilaster has been secured to the mounting hardware. Leave the appropriate door opening between the pilasters as shown on your submittal drawing.
- ✓ The illustrations on this page show mounting hardware and fasteners for a generic application. Refer to your submittals to determine your actual headrail configurations.
- ✓ Some headrail sections may need to be cut to an appropriate size. Refer to your submittals for general headrail placement.
- ✓ Headrail configurations that come to an intersection should meet over pilaster (see completed headrail assembly view below).

A Place headrail over the top of each pilaster located at the wall and slide it tight against the side wall. Mark the outline of the headrail on the wall and remove the headrail.

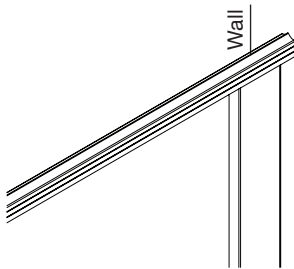

B Place the headrail bracket on the outline marked on the wall and mark the locations of the mounting holes. Remove bracket and drill (2) $\text{Ø}5/16"$ holes a minimum of 2" [51 mm] deep. Prior to securing to the wall, enlarge the (2) back mounting holes of the bracket to $\text{Ø}1/4"$. Secure the bracket to the wall with the #14 x 2" screws and plastic anchors provided.

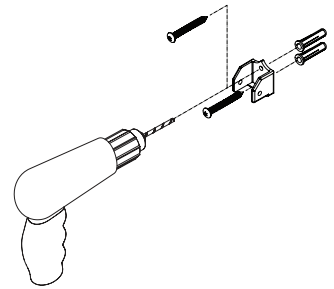

C Place headrail over the top of the pilasters and slide it tight into the mounting bracket. Use the mounting bracket as a template and drill a $\text{Ø}7/32"$ hole through the headrail. Secure the headrail to the mounting bracket with the #10 x 5/8" screws provided.

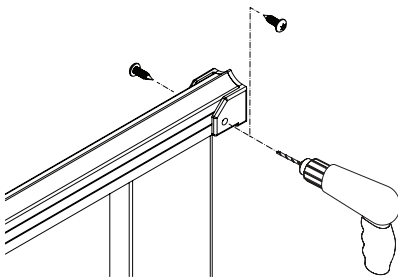

D Make sure the pilaster is plumb and that the spacing between the pilasters for the doors is the correct dimension. On the back of each pilaster (starting with the first pilaster), drill a $\text{Ø}7/32"$ hole through one face of the headrail only.

Using this hole as a template, drill a $\text{Ø}9/64"$ pilot hole into the pilaster, 5/8" (16mm) deep. Secure the headrail to the back of each pilaster with the #10 x 5/8" screws provided.

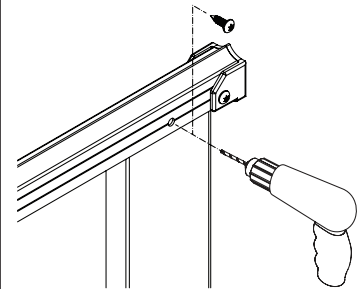

E For open end applications, cut the headrail to the appropriate length (if required). Attach the bracket to the wall at the correct height (see step B). Attach another bracket to a pilaster with #10 x 5/8" screws at the correct height (see view below). The headrail should be level with any adjacent headrail and should be located directly over the panel. Position each headrail onto the brackets and secure with required fasteners (see step C). Using a rubber mallet, install the headrail end cap.

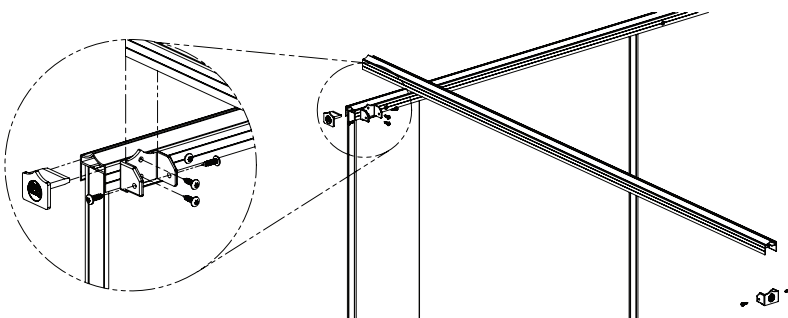

Completed Headrail Assembly

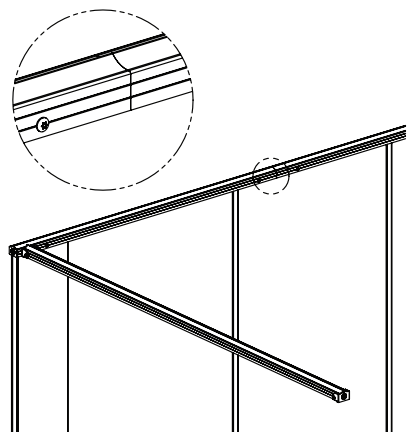

8 Pilaster Shoes

A Position pilaster shoe so that it rests flush with the floor.

B Using the hole(s) in the shoe as a template, drill a $\text{Ø}9/64$ " pilot hole (through inside face of pilaster only). Secure the shoe to the pilaster using the #10 x 5/8" fastener(s) provided.

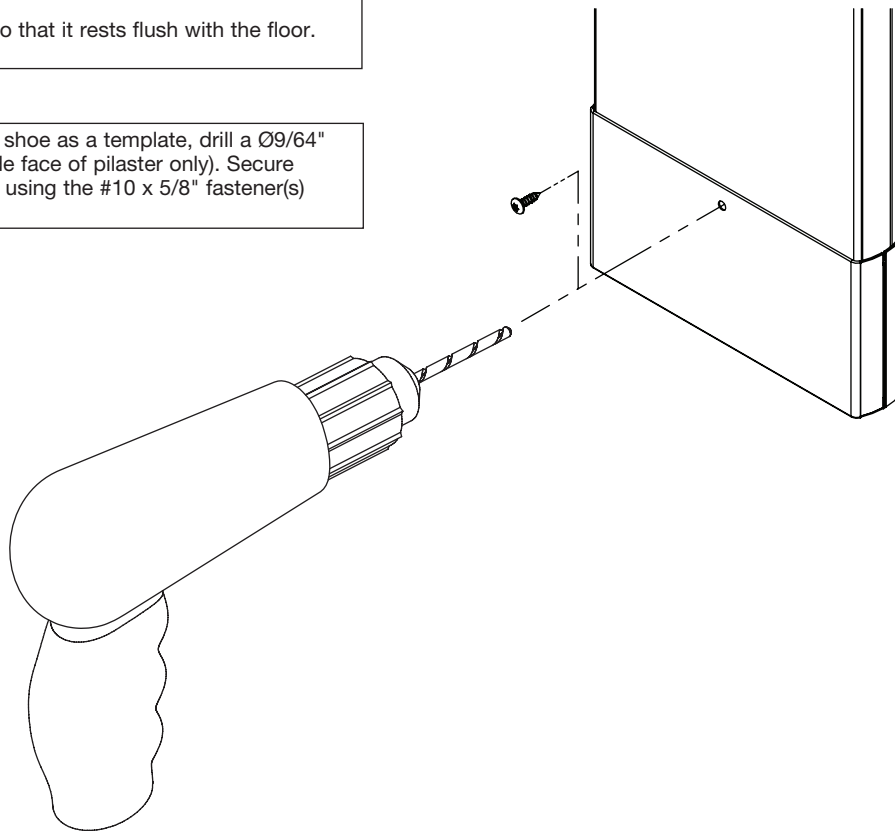

9 Wraparound Gravity Hinges (Standard)

- Before installing the hinges, make sure the door openings are the appropriate size, all pilasters are plumb, secured to the floor and that the headrail is installed.
- Refer to your submittal drawings to determine each specific door swing for your application. The door swing is determined by facing the compartment from the outside. The image below can help determine the door swing type.

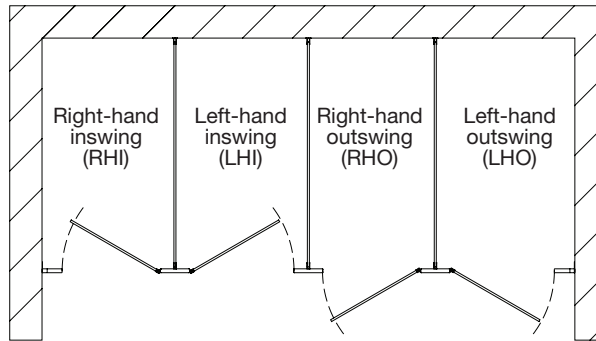

A Measure down from the top of the pilaster and place a mark at dimensions "A" and "B" for the respective pilaster type (see table below). This mark represents the upper hole location of the top and bottom hinge.

B Using the hinge as a template, drill $\varnothing 1/4"$ holes through the pilaster.

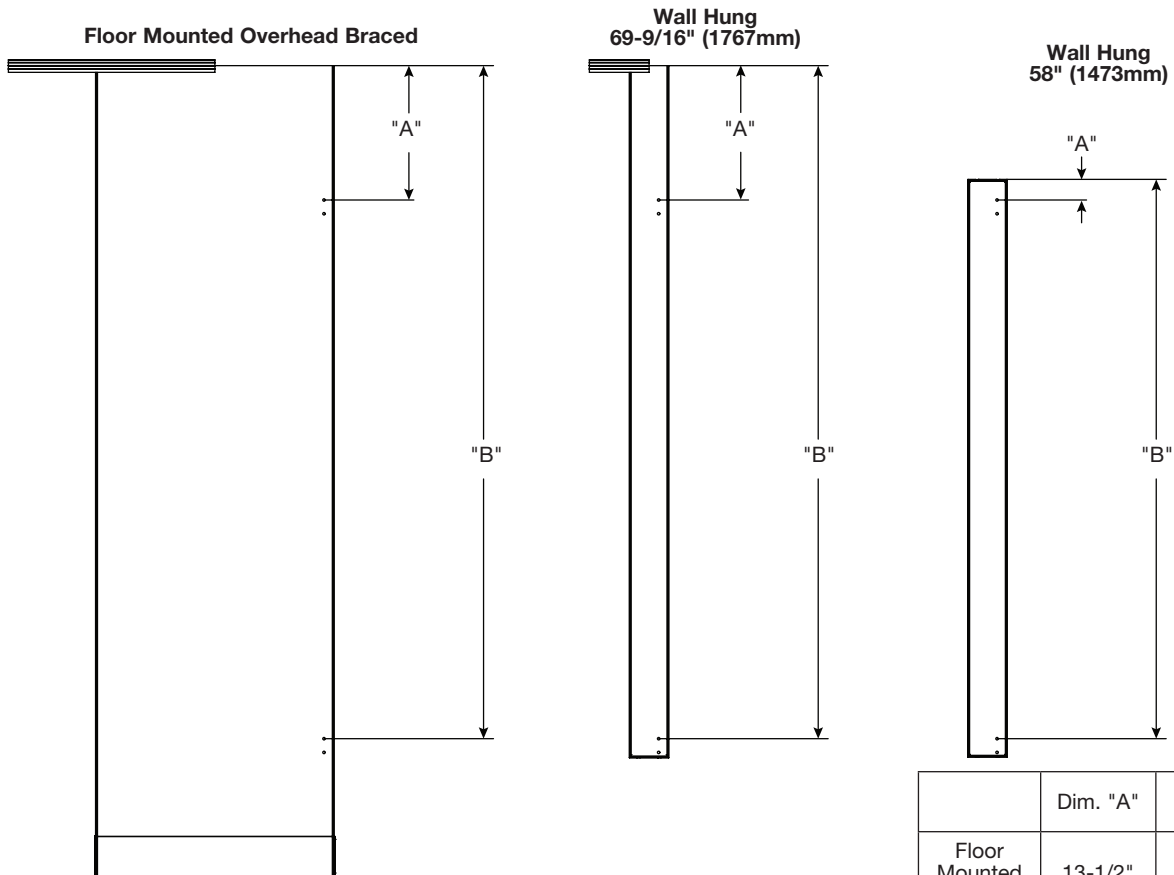

	Dim. "A"	Dim. "B"
Floor Mounted Overhead Braced	13-1/2" (343mm)	67-5/8" (1718mm)
Wall Hung 69-9/16" (1767mm)	13-1/2" (343mm)	67-5/8" (1718mm)
Wall Hung 58" (1473mm)	2-1/16" (52mm)	56-3/16" (1427mm)

- For 58" wall hung pilaster, establishing dimensions "A" and "B" as shown in the table will result in the top of the door being flush with the top of the pilaster when the desired cam setting on the door is set to 0°.

9 Wraparound Gravity Hinges (Continued)

- ✓ The door hinge assembly consists of separate door and pilaster hardware.
- ✓ Door cam surfaces can become worn under normal use. The application of lithium grease can help prolong door cam life and reduce friction between surfaces.

C Secure the top and bottom pilaster hinge to the pilaster with the #10-24 x 3/4" barrel nuts and #10-24 x 1" shoulder screws provided.

D Assemble the bottom hinge cam and pin as shown. Insert into the bottom hinge and thread the locknut loosely onto the bottom hinge pin.

E Place the bottom door hinge opening onto the bottom pilaster hinge. Position the top door hinge opening into the top pilaster hinge and insert the top hinge pin.

- ✓ The top hinge pin should snap securely into place.

F Rotate the door to the desired "at rest" position. Push down on the door while holding it in the "at rest" position. This sets the male and female cams in the bottom hinge. Tighten the hex nut to secure the door in the "at rest" position.

- ✓ For doors requiring a full close, rotate the door 15° past the closed position.

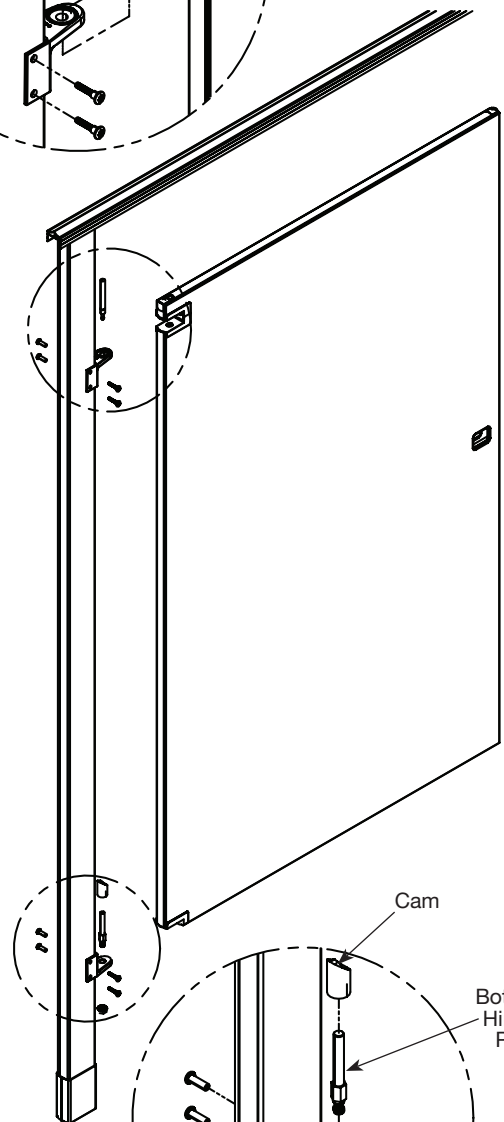
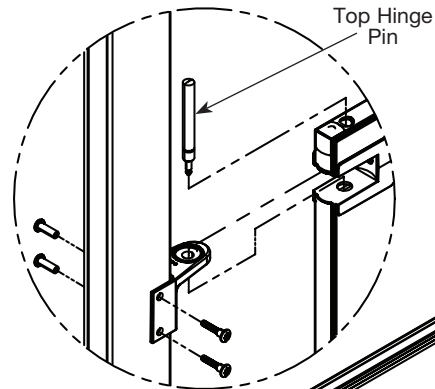

Finished View of Top Hinge

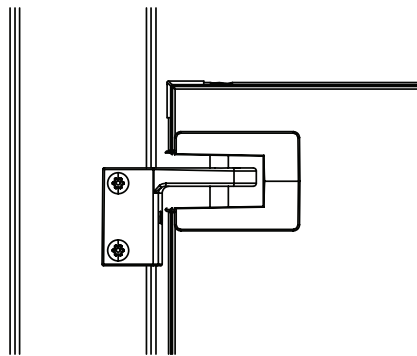

Finished View of Bottom Hinge

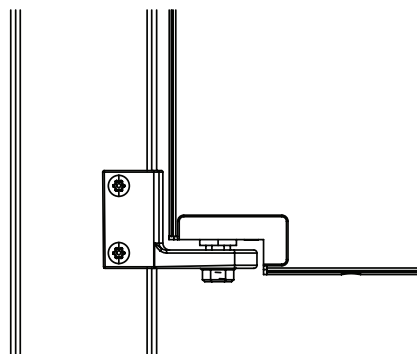

9a Continuous Spring-Loaded Piano Hinge (Optional)

- Before installing the hinges, make sure the door openings are the appropriate size, all pilasters are plumb, secured to the floor and that the headrail is installed.
- Refer to your submittal drawings to determine each specific door swing for your application. The door swing is determined by facing the compartment from the outside. The image below can help determine the door swing type.

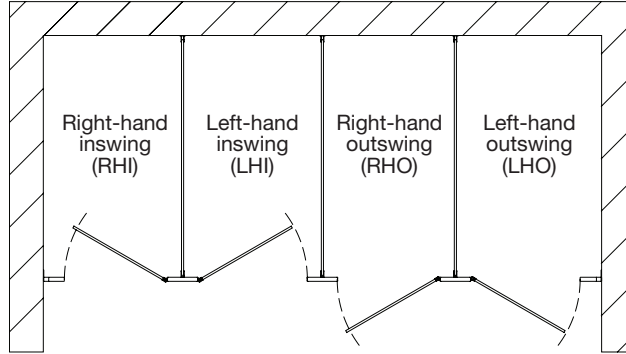

<p>Continuous Piano Hinge</p> <p>The part numbers listed are prefixes only and are used to identify the appropriate door kit based on your door swing as determined above. Inswinging doors should have hinges mounted on the inside of the stall while outswinging doors should have hinges mounted on the outside of the stall.</p>	<p>Part # Prefix HDWT-S0209 (left hand in, right hand out, knuckles facing front)</p> <p>Door side Pilaster side</p>	<p>Part # Prefix HDWT-S0208 (right hand in, left hand out, knuckles facing front)</p> <p>Door side Pilaster side</p>
--	---	---

A Place a door on a 12" (305mm) spacer and set the door gaps. Standard hinge side gap is 9/32" (7mm).

B Position the hinge so it is plumb and centered within the 9/32" (7mm) gap and centered top to bottom (approximately 1/4" (6mm) down from the top of the door).

C Using the hinge as a template, drill Ø1/4" holes through the door at the top and bottom holes. Secure the hinge to the door using the #10-24 x 3/4" stainless barrel nuts and #10-24 x 3/4" stainless shoulder screws provided.

D Check to make sure the hinge side gap is still at 9/32" (7mm). Using the hinge as a template drill Ø1/4" holes through the pilaster at the top and bottom holes. Secure the hinge to the pilaster using the #10-24 x 3/4" stainless barrel nuts and #10-24 x 1" stainless shoulder screws provided.

E Drill Ø1/4" holes through the remaining hinge holes on the door and pilaster. Secure with the fasteners provided.

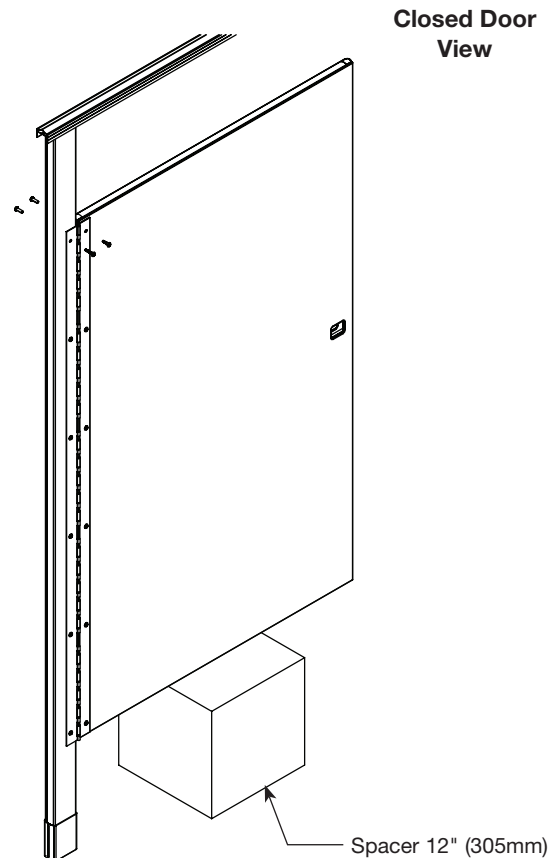

9b Stainless Steel Flat Hinge (Optional)

 See Step 1 for instructions on laying out pilaster plumb line.

A From the highest point in the room, measure 12" (305mm) and 68-3/8" (1737mm) from the floor. Use a level to transfer these marks to the pilaster plumb line.

B Position the bottom of the bottom flat hinge on the 12" (305mm) mark and center on the pilaster plumb line. Using the flat hinge as a template, mark the hole locations on the wall. Remove the flat hinge and drill a Ø1/4" hole (minimum 2" [51mm] deep) at each hole location.

C Position the top of the top flat hinge on the 68-3/8" (1737mm) mark and center on the pilaster plumb line. Using the flat hinge as a template, mark the hole locations on the wall. Remove the flat hinge and drill a Ø1/4" hole (minimum 2" [51mm] deep) at each hole location.

D Insert plastic anchors in all holes and secure the flat hinges to the wall with #10 x 2" stainless flat head screws provided.

E See Step 9, D thru F for instructions on attaching the door to the hinge.

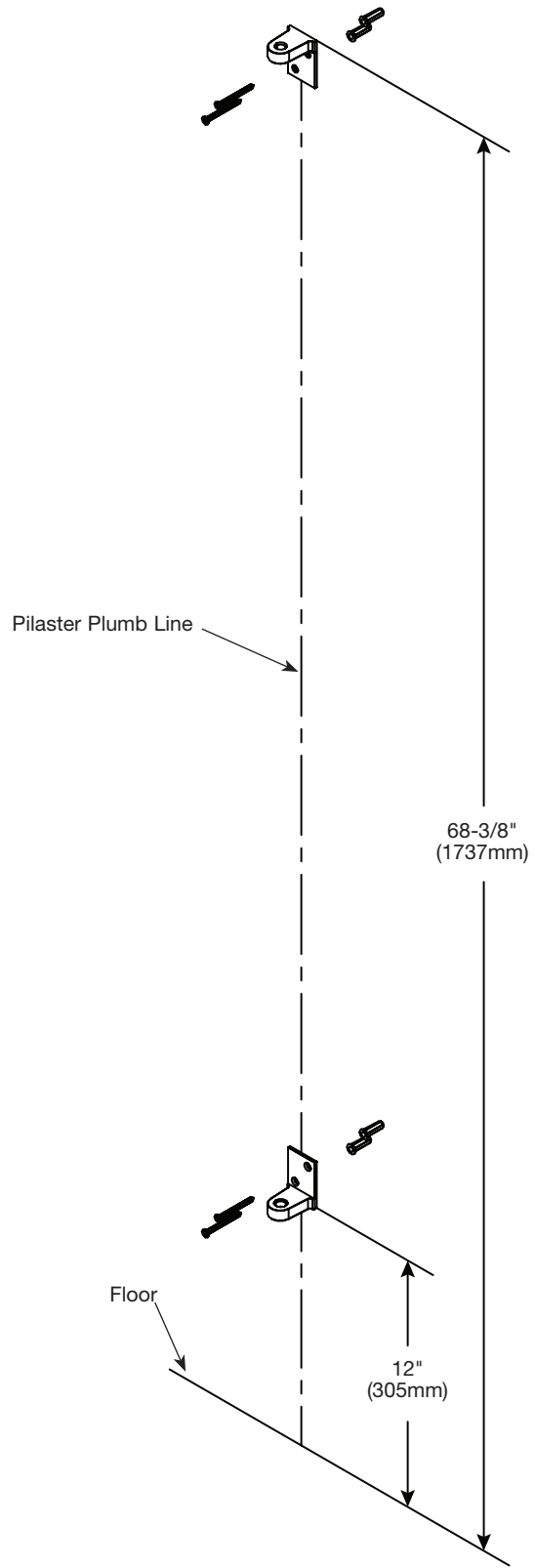

10 Door Hardware for Inswing Doors - Concealed

 Local codes vary from state to state. Check your local codes before installing the coat hook and door pulls.

A Assemble the latch as shown. Tighten the fasteners and insert the latch bolt, pushing in until it snaps into place.

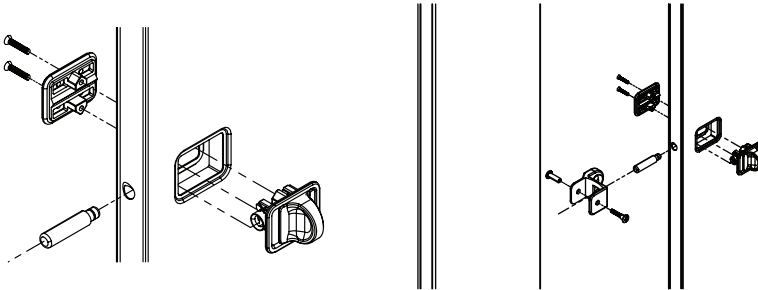

B Place the strike/keeper on the pilaster and center it on the opposing latch bolt. Using the strike/keeper as a template, mark the hole locations on the pilaster. Remove the strike/keeper and drill an Ø1/4" hole through the pilaster. Secure to the pilaster with the #10-24 x 3/4" barrel nut and #10-24 x 1" shoulder screw provided.

C For 34" - 36" doors, mark the location for the top hole on the inside face of the door 30-3/4" (781mm) up from the bottom of 58" tall doors (42-3/4" (1086mm) above finished floor) and 4" (102mm) from the door edge. Drill (2) Ø1/4" holes (spaced 3-1/2" (89mm) apart) through the door and secure the door pulls to the door with the #10-24 x 2" flat machine screws provided.

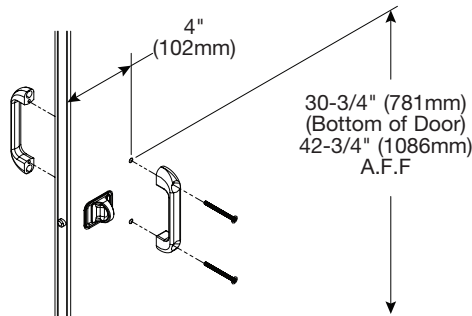

D Place the coat hook 3" (76mm) down from the top and 3" (76mm) from the latch side of the door (hook goes on the inside face of the door). Using the coat hook as a template, drill (2) Ø9/64" pilot holes through inside face of the door only. Secure the coat hook with the #10 x 5/8" screws provided.

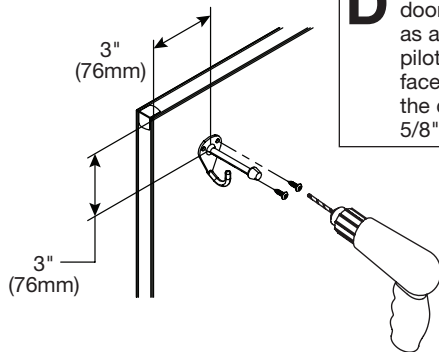

Flat Strike/Keeper

E With the door in the closed position, place flat strike/keeper so the slot is centered around the latch bolt.

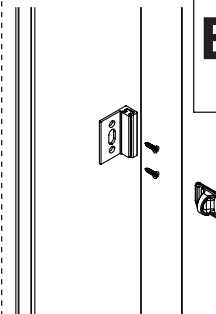

F Using the flat strike/keeper as a template drill (2) Ø1/8" pilot holes through one face of the pilaster only. Secure the flat strike/keeper with the #10 x 3/4" flat head screws provided.

10a Door Hardware for Inswing Doors - Surface

 Local codes vary from state to state. Check your local codes before installing the coat hook and door pulls.

A Position latch centered top to bottom and with the leading edge 3/8" (10mm) from the door edge. Using the latch as a template, mark the hole locations and drill Ø1/4" holes through the door. Secure latch to door with the #10-24 x 3/4" barrel nuts and #10-24 x 3/4" shoulder screws provided.

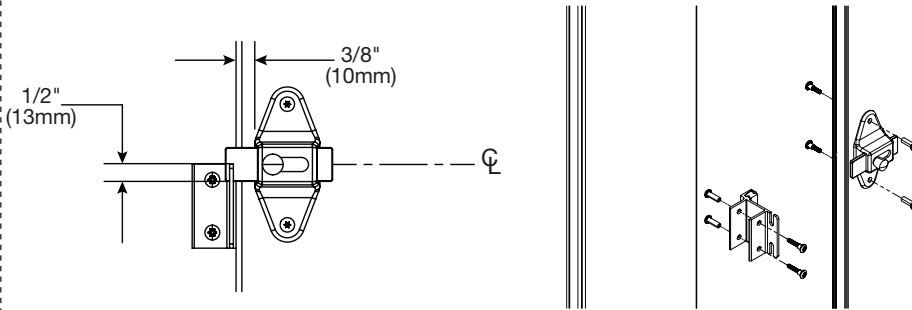

B With the door in the closed position, position the strike/keeper on the pilaster and align the top so it is 1/2" (13mm) above the bottom of the latch slide bar. Using the strike/keeper as a template, mark the hole locations and drill Ø1/4" holes through the pilaster. Secure the strike/keeper to the pilaster with the #10-24 x 3/4" barrel nuts and #10-24 x 1" shoulder screws provided.

C For 34" - 36" doors, mark the location for the top hole on the inside face of the door 30-3/4" (781mm) up from the bottom of 58" tall doors (42-3/4" (1086mm) above finished floor) and 5-1/2" (140mm) from the door edge. Drill (2) Ø1/4" holes (spaced 3-1/2" (89mm) apart) through the door and secure the door pulls to the door with the #10-24 x 2" flat machine screws provided.

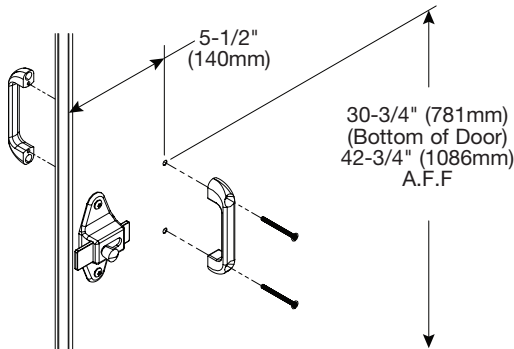

D Place the coat hook 3" (76mm) down from the top and 3" (76mm) from the latch side of the door (hook goes on the inside face of the door). Using the coat hook as a template, drill (2) Ø9/64" pilot holes through inside face of the door only. Secure the coat hook with the #10 x 5/8" screws provided.

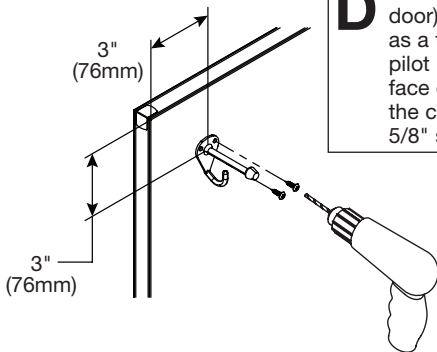

Flat Strike/Keeper

E With the door in the closed position, place flat strike/keeper so the latch slide bar fits within the top notch.

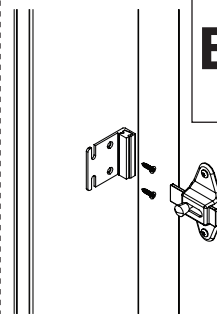

F Using the flat strike/keeper as a template, drill (2) Ø1/8" pilot holes through one face of the pilaster only. Secure the flat strike/keeper with the #10 x 3/4" flat head screws provided.

10b Door Hardware for Outswing Doors - Concealed

 Local codes vary from state to state. Check your local codes before installing the coat hook and door pulls.

A Assemble the latch as shown. Tighten the fasteners and insert the latch bolt, pushing in until it snaps into place.

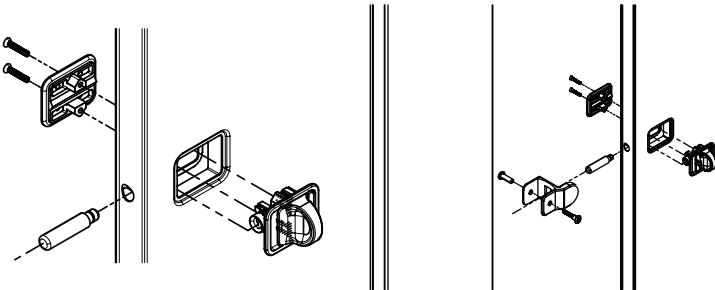

B Place the strike/keeper on the pilaster and center it on the opposing latch bolt. Using the strike/keeper as a template, mark the hole locations on the pilaster. Remove the strike/keeper and drill a $\text{Ø}1/4"$ hole through the pilaster. Secure to pilaster with the #10-24 x 3/4" barrel nut and #10-24 x 1" shoulder screw provided.

C Mark the location for the top hole on the inside face of the door 30-3/4" (781mm) up from the bottom of 58" tall doors (42-3/4" [1086mm] above finished floor) and 4" (102mm) from the door edge. Drill (2) $\text{Ø}1/4"$ holes (spaced 3-1/2" [89mm] apart) through the door and secure the door pulls to the door as shown with the #10-24 x 2" flat machine screws provided.

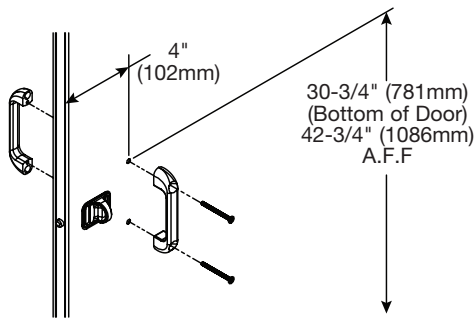

D Position the wall bumper 3" (76mm) up from the bottom and 3" (76mm) from the latch side of the door (bumper goes on the outside face of the door). Using the bumper as a template, drill (2) $\text{Ø}9/64"$ pilot holes through outside face of the door only and secure to door with the #10 x 5/8" screws provided.

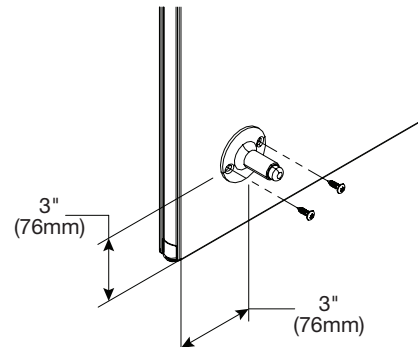

Flat Strike/Keeper

F With the door in the closed position, place flat strike/keeper so the slot is centered around the latch bolt.

G Using the flat strike/keeper as a template, drill (2) $\text{Ø}1/8"$ pilot holes through one face of pilaster only. Secure the flat strike/keeper to the pilaster using the #10 x 3/4" flat head screws provided.

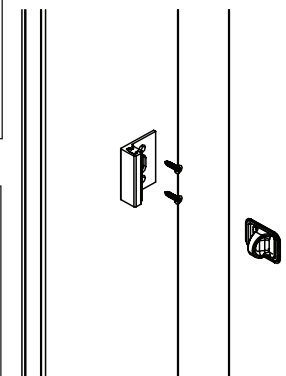

E Position the coat hook 36" (914mm) above finished floor (hook goes on the inside of compartment). Using the hook as a template, drill (2) $\text{Ø}3/16"$ pilot holes through inside face of the pilaster only and secure with the #14 x 5/8" screws provided.

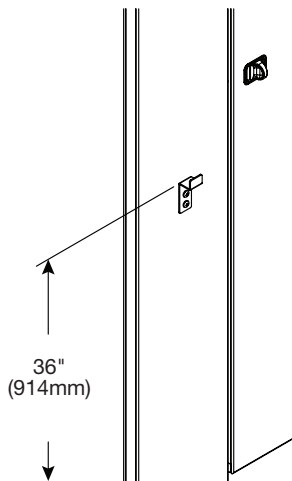

10c Door Hardware for Outswing Doors - Surface

 Local codes vary from state to state. Check your local codes before installing the coat hook and door pulls.

A Position latch centered top to bottom and with the leading edge 1" (25mm) from the door edge. Using the latch as a template, mark the hole locations and drill $\text{Ø}1/4"$ holes through the door. Secure latch to door with the #10-24 x 3/4" barrel nuts and #10-24 x 3/4" shoulder screws provided.

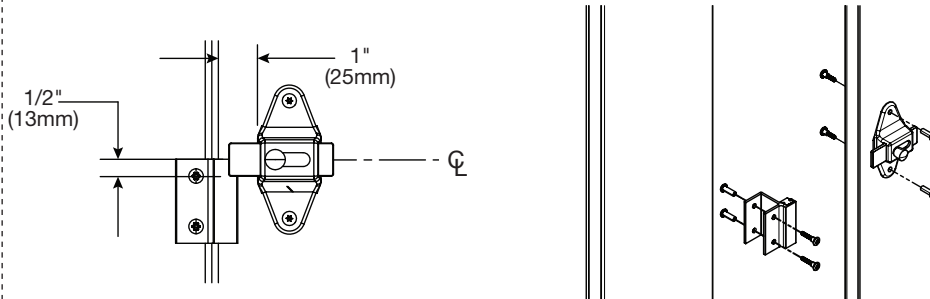

B With the door in the closed position, position the strike/keeper on the pilaster and align the top so it is 1/2" (13mm) above the bottom of the latch slide bar. Using the strike/keeper as a template, mark the hole locations and drill $\text{Ø}1/4"$ holes through the pilaster. Secure the strike/keeper to the pilaster with the #10-24 x 3/4" barrel nuts and #10-24 x 1" shoulder screws provided.

C Mark the location for the top hole on the inside face of the door 30-3/4" (781mm) up from the bottom of 58" tall doors (42-3/4" [1086mm] above finished floor) and 5-1/2" (140mm) from the door edge. Drill (2) $\text{Ø}1/4"$ holes (spaced 3-1/2" [89mm] apart) through the door and secure the door pulls to the door as shown with the #10-24 x 2" flat machine screws provided.

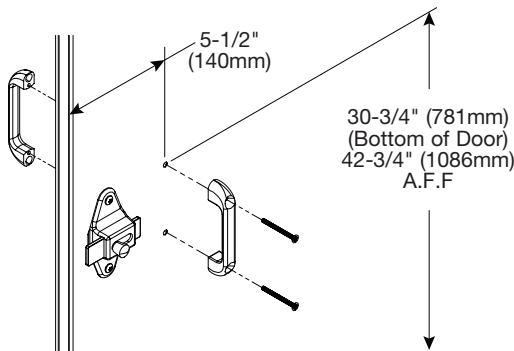

D Position the wall bumper 3" (76mm) up from the bottom and 3" (76mm) from the latch side of the door (bumper goes on the outside face of the door). Using the bumper as a template, drill (2) $\text{Ø}9/64"$ pilot holes through outside face of the door only and secure to door with the #10 x 5/8" screws provided.

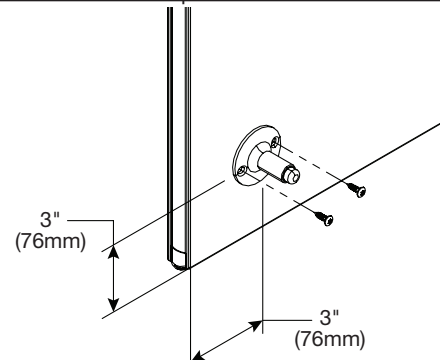

Flat Strike/Keeper

F With the door in the closed position, position the flat strike/keeper on the pilaster and align the top so it is 1/2" (13mm) above the bottom of the latch slide bar.

G Using the flat strike/keeper as a template, drill (2) $\text{Ø}1/8"$ pilot holes through one face of pilaster only. Secure the flat strike/keeper to the pilaster using the #10 x 3/4" flat head screws provided.

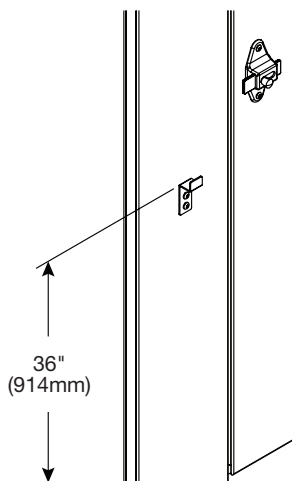
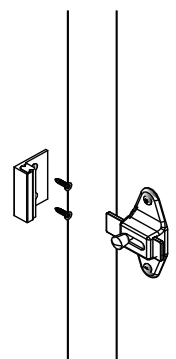

E Position the coat hook 36" (914mm) above finished floor (hook goes on the inside of compartment). Using the hook as a template, drill (2) $\text{Ø}3/16"$ pilot holes through inside face of the pilaster only and secure with the #14 x 5/8" screws provided.

11 Urinal Screens with Stirrup Brackets (Standard)

 Before installing the urinal screen components, determine the correct location for your application.

A Draw a plumb line on the wall to represent the urinal screen centerline. Measure from the highest point in the room and place a mark on the urinal screen centerline at dimensions "A" and "B" for the respective urinal screen height (see table below).

B Position and center brackets at each mark and urinal screen centerline. Using the bracket as a template, mark the hole locations on the wall. Remove the bracket and drill a $\text{Ø}5/16"$ hole (minimum 2" [51mm] deep) at each hole location.

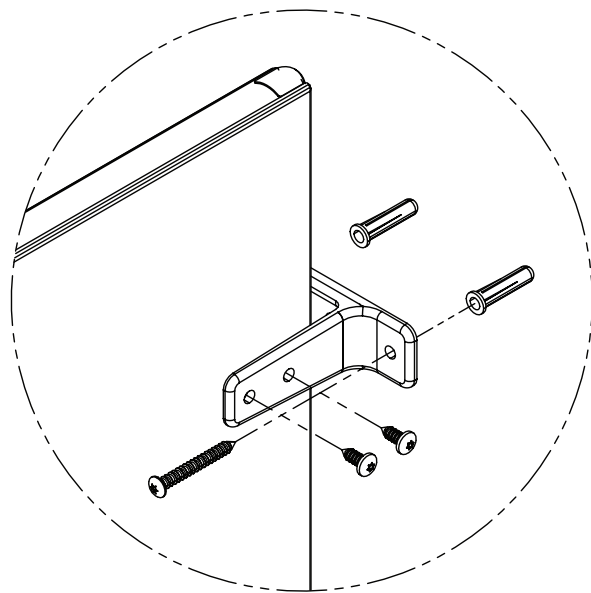

C Insert plastic anchors in all holes and secure bracket to the wall with the #14 x 2" screws provided.

D Place the urinal screen at dimension "C" for the respective urinal screen height (see table on right) and insert it into the wall brackets until a 1" (25mm) gap between the wall and urinal screen is established.

E Using the bracket as a template, drill $\text{Ø}3/16"$ holes through the urinal screen at each bracket hole. Secure the urinal screen to the brackets with the #14 x 5/8" screws provided.

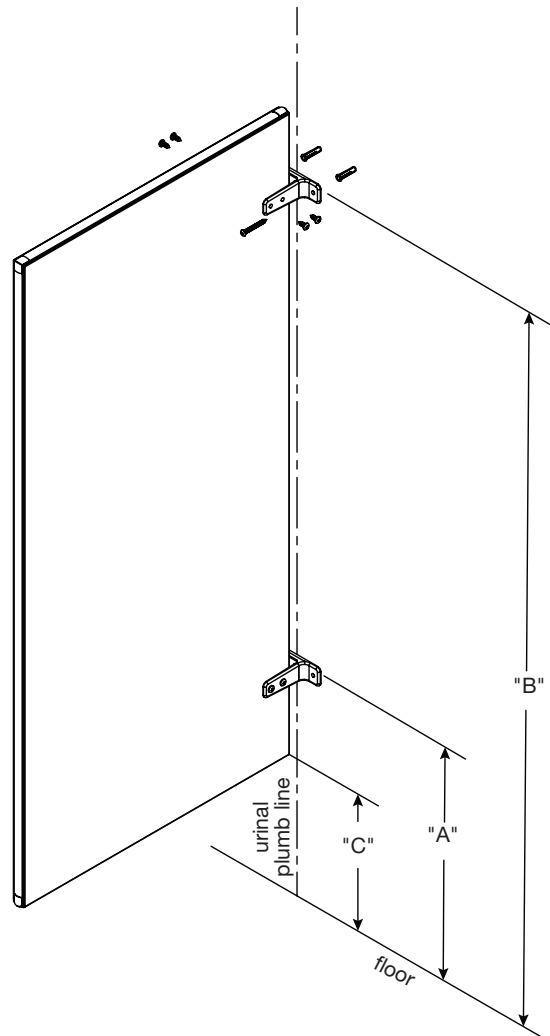

	Dim "A" (mm)	Dim "B" (mm)	Dim "C" (mm)
42" Urinal Screen	24" (610)	54" (1372)	18" (457)
48" Urinal Screen	18" (457)	54" (1372)	12" (305)

11a Urinal Screens with Continuous Stainless Steel Brackets (Optional)

- Before installing the urinal screen components, determine the correct location for your application.
- Brackets are used as templates, but since the hole patterns may be different, the brackets may not be interchangeable.

A Draw a plumb line on the wall to represent the urinal screen centerline. Measure from the highest point in the room and place a mark on the urinal screen centerline at dimension "A" for the respective urinal screen height (see table below).

B Place the bottom of the bracket on the mark and center the opening on the urinal screen centerline. Using the bracket as a template, mark the hole locations on the wall. Remove the bracket and drill a Ø5/16" hole (minimum 2" [51mm] deep) at each hole location.

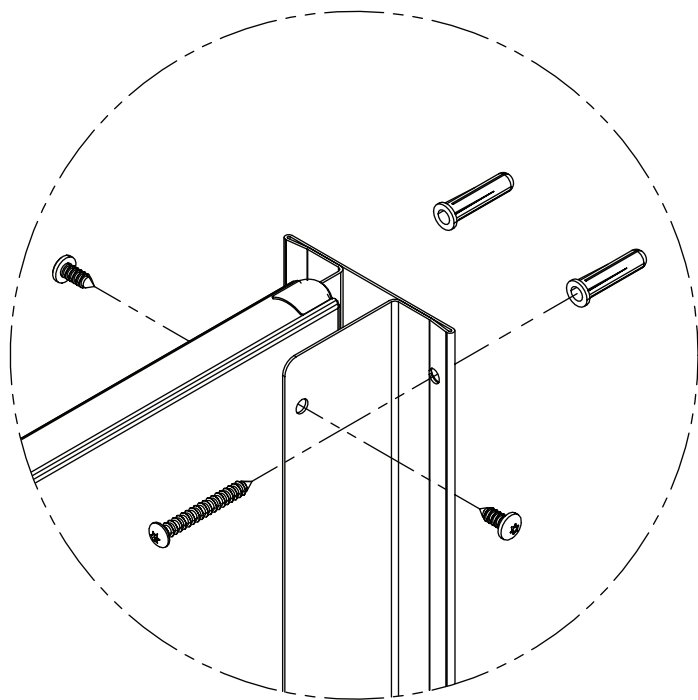

C Insert plastic anchors in all holes and secure bracket to the wall with the #14 x 2" stainless screws provided.

D Place the urinal screen at dimension "B" for the respective urinal screen height (see table on right) and insert it into the wall bracket until a 1" (25mm) gap between the wall and urinal screen is established.

E Using the bracket as a template, drill Ø3/16" holes through the urinal screen at each bracket hole. Secure the urinal screen to the bracket with the #14 x 5/8" stainless screws provided.

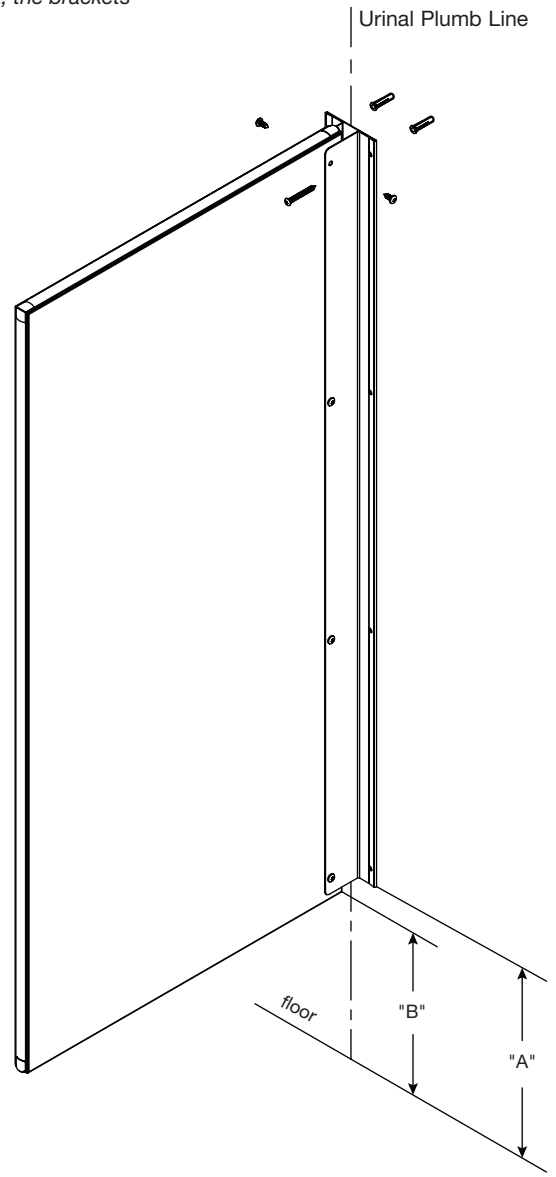

	Dim "A" (mm)	Dim "B" (mm)
42" Urinal Screen	18-1/2" (470)	18" (457)
48" Urinal Screen	12-1/2" (318)	12" (305)

11b Urinal Screens with Continuous Aluminum Brackets (Optional)

- Before installing the urinal screen components, determine the correct location for your application.
- Brackets are used as templates, but since the hole patterns may be different, the brackets may not be interchangeable.

A Draw a plumb line on the wall to represent the urinal screen centerline. Measure from the highest point in the room and place a mark on the urinal screen centerline at dimension "A" for the respective urinal screen height (see table below).

B Place the bottom of the bracket on the mark and center the opening on the urinal screen centerline. Using the bracket as a template, mark the hole locations on the wall. Remove the bracket and drill a Ø5/16" hole (minimum 2" [51mm] deep) at each hole location.

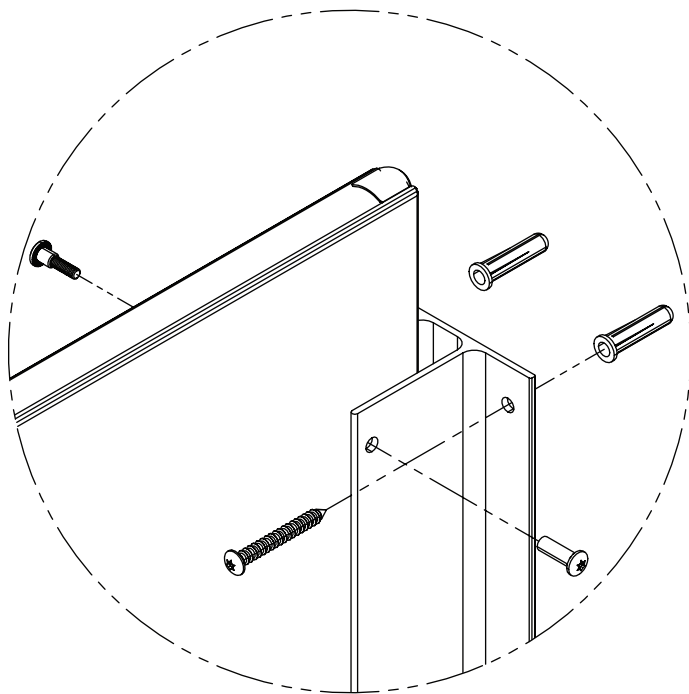

C Insert plastic anchors in all holes and secure bracket to the wall with the #14 x 2" stainless screws provided.

D Place the urinal screen at dimension "B" for the respective urinal screen height (see table on right) and insert it into the wall bracket until a 1" (25mm) gap between the wall and urinal screen is established.

E Using the bracket as a template, drill Ø1/4" holes through the urinal screen at each bracket hole. Secure the urinal screen to the bracket with the #10-24 x 3/4" stainless barrel nuts and #10-24 x 3/4" stainless shoulder screws provided.

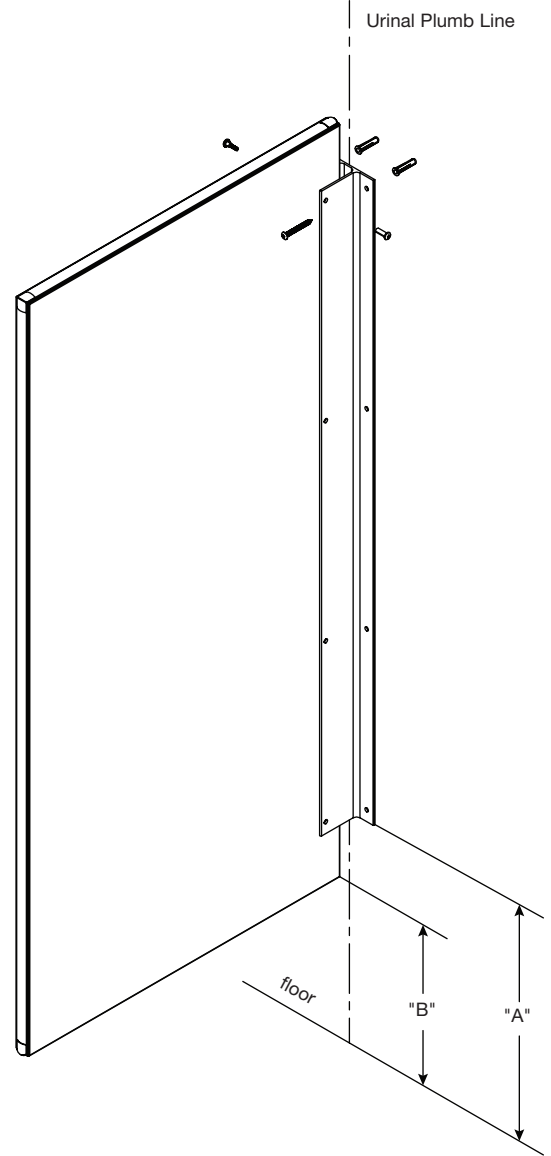

	Dim "A" (mm)	Dim "B" (mm)
42" Urinal Screen	18-1/4" (464)	18" (457)
48" Urinal Screen	15-1/4" (387)	12" (305)